



Planning Commission Staff Report

Meeting Date: February 7, 2017

Subject: Tentative Subdivision Map Case Number WTM16-003 (Bailey Creek Estates)

Applicant: Silver Crest Homes

Agenda Item Number: 9B

Project Summary: 56-lot single-family residential common open space subdivision

Recommendation: Approval with Conditions

Prepared by: Kelly Mullin, Planner
Washoe County Community Services Department
Planning and Development Division
775.328.3608
kmullin@washoecounty.us

Description

Tentative Subdivision Map Case Number WTM16-003 (Bailey Creek Estates) – Hearing, discussion, and possible action to approve a 56-lot single-family residential subdivision on two parcels totaling ±28.76 acres. Residential lots will range in size from 14,520 sq. ft. (±0.33-acres) to 21,780 sq. ft. (±0.81-acres) with lot sizes averaging 17,869 sq. ft. (±0.41-acres). The subdivision includes approximately ±0.75-acres of common area for drainage facilities.

- Applicant: Silver Crest Homes, Attn: Rich Balestreri, 16500 Wedge Parkway, Bldg. A, Suite 200, Reno, NV 89511
- Property Owner: Charles Maddox, P.O. Box 70577, Reno, NV 89570
- Location: Immediately south of the intersection of Geiger Grade Road and Shadow Hills Drive
- Assessor's Parcel Numbers: 017-520-03 and 017-480-02
- Parcel Sizes: 23.63-acres and 5.125-acres
- Area Plan: Southeast Truckee Meadows (SETM)
- Master Plan Categories: Suburban Residential and Rural
- Regulatory Zones: Medium Density Suburban (2 dwelling units per acre in SETM) and General Rural (1 dwelling unit per 40 acres)
- Citizen Advisory Board: South Truckee Meadows/Washoe Valley
- Development Code: Article 608, *Tentative Subdivision Maps* and Article 408, *Common Open Space Development*
- Commission District: 2 – Commissioner Lucey
- Section/Township/Range: Sections 27 and 34, T18N, R20E, MDM, Washoe County, NV

Staff Report Contents

Project Description..... 1

Tentative Subdivision Map Process 3

Vicinity Map 4

Site Plan 5

Project Evaluation 6

Relevant Southeast Truckee Meadows Area Plan Policies 9

South Truckee Meadows/Washoe Valley Citizen Advisory Board (STM/WV CAB)..... 10

Reviewing Agencies..... 10

Staff Comment on Required Findings 12

Recommendation..... 14

Motion..... 14

Appeal Process..... 14

Exhibit Contents

Conditions of Approval..... Exhibit A

Agency Comments..... Exhibit B

Public Notice Map Exhibit C

Public Comment Letters..... Exhibit D

Project Application Exhibit E

Traffic Impact Report, Dated December 2016 Exhibit F

Map of Approved Residential Subdivisions in Vicinity of Toll Road..... Exhibit G

Tentative Subdivision Map Process

The purpose of a Tentative Subdivision Map is:

- To allow the creation of saleable lots;
- To implement the Washoe County Master Plan, including the Area Plans;
- To establish reasonable standards of design and reasonable procedures for subdivision and re-subdivision in order to further the orderly layout and use of land and insure proper legal descriptions and monumenting of subdivided land; and;
- To safeguard the public health, safety and general welfare by establishing minimum standards of design and development for any subdivision platted in the unincorporated area of Washoe County.

If the Planning Commission grants approval of the Tentative Subdivision Map, that approval is subject to Conditions of Approval. Conditions of Approval are requirements that need to be completed during different stages of the proposed project. Those stages are typically:

- Prior to recordation of a final map.
- Prior to obtaining a final inspection and/or a certificate of occupancy on a structure.
- Prior to the issuance of a business license or other permits/licenses.
- Some Conditions of Approval are referred to as "Operational Conditions." These conditions must be continually complied with for the life of the project.

The Conditions of Approval for Tentative Subdivision Map Case Number WTM16-003 are attached to this staff report and will be included with the Action Order if the Planning Commission approves the application.

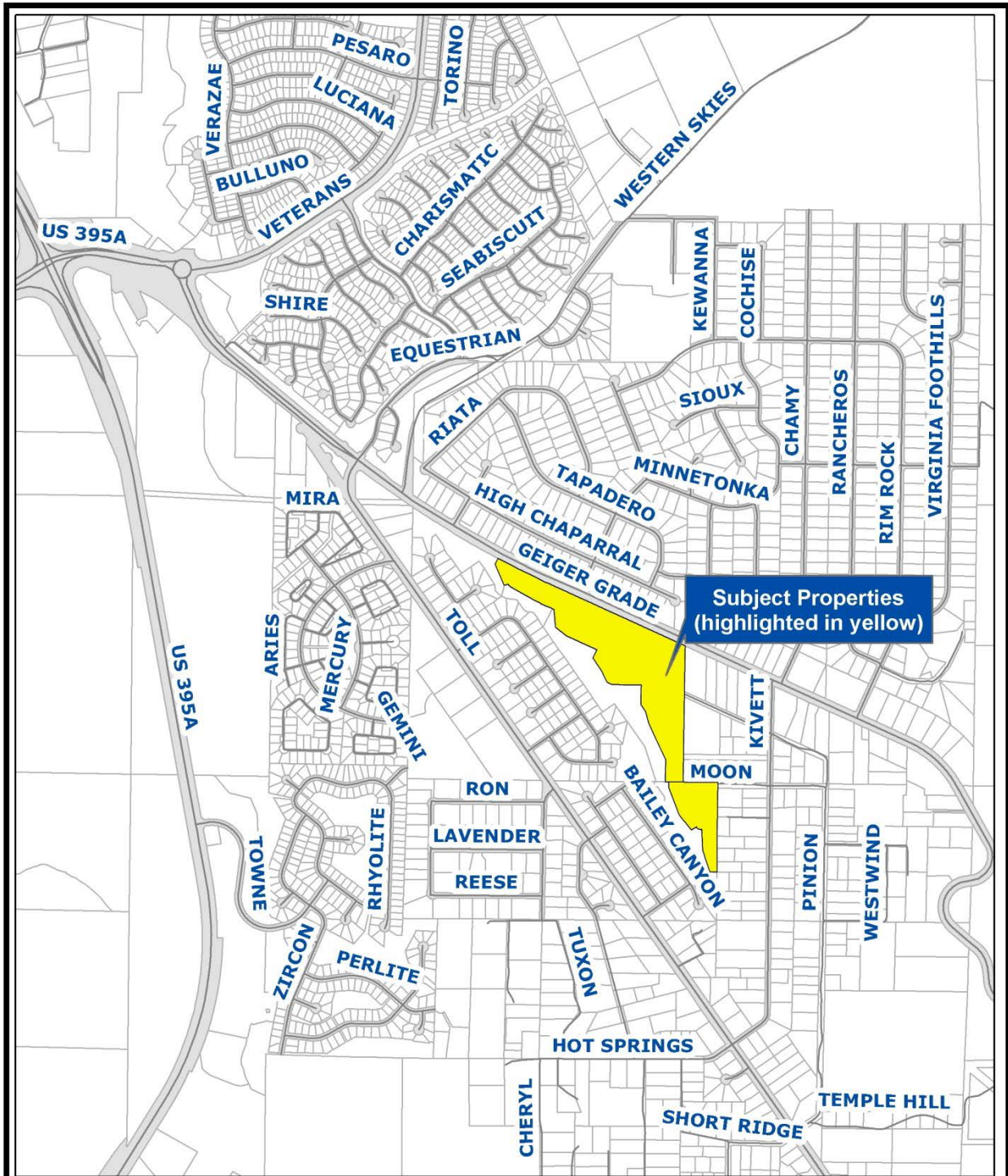

Tentative Subdivision Map Case No. WTM16-003
Bailey Creek Estates

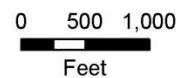

Date: January 13, 2017

Community Services
 Department, Planning
 and Development



Post Office Box 11130
 Reno, Nevada 89520 (775) 328-3600

Source: Planning & Development

Vicinity Map

Project Evaluation

The applicants are proposing to develop a 56-lot single-family residential subdivision on two parcels totaling ± 28.76 acres. The property has a regulatory zone of Medium Density Suburban (MDS), with a small portion of the property zoned General Rural (GR). In the Southeast Truckee Meadows Area Plan, MDS properties are limited to two dwelling units per acre, and the proposed subdivision maximizes its density with 56 residential lots. These residential lots will range in size from 14,520 sq. ft. (± 0.33 -acres) to 21,780 sq. ft. (± 0.81 -acres) with lot sizes averaging 17,869 sq. ft. (± 0.41 -acres). The subdivision also includes five smaller parcels that together total approximately ± 0.75 -acres of common area for drainage facilities.

The Southeast Truckee Meadows Area Plan identifies the subject site as being located within the Suburban Character Management Plan and Toll Road Character Management Area. As identified later in this report, the project is in compliance with the policies for these two areas.

Compatibility

This infill subdivision is situated between other residential developments sharing the same Medium Density Suburban regulatory zone.

- **West:** To the west of the property, across Bailey Canyon Creek, is the Cottonwood Creek Estates subdivision – a common open space development with the nearest lots ranging from approximately 1/4-acre to 1/3-acre in size. The Cottonwood Creek Estates subdivision's common open space separates it from the proposed Bailey Creek Estates project.
- **North:** Across Geiger Grade to the north are the Shadow Hills and Sagewood Estates subdivisions, which also share the MDS regulatory zone. Many of these lots are approximately 1/2-acre in size.
- **East:** To the east of the subject site are additional properties sharing the MDS regulatory zone, with the exception that they are also within a Trailer Overlay zone. These properties range in size from $\pm 1/2$ -acre to ± 3.75 acres and are individually developed residential properties. To the northeast is an area of several parcels with the General Commercial regulatory zone. The commercially zoned property abutting the northeast corner of the project site is currently undeveloped.
- **South:** To the south is the Comstock Estates subdivision, which contains additional MDS properties approximately 1/3 acre in size.

The Southeast Truckee Meadows Area Plan contains several policies requiring proposed development to minimize potential impacts to neighboring properties. These policies, and associated conditions of approval, are discussed beginning on page 9 of this staff report. Additionally, construction hours will be limited to 7 a.m. to 7 p.m., Monday through Saturday.

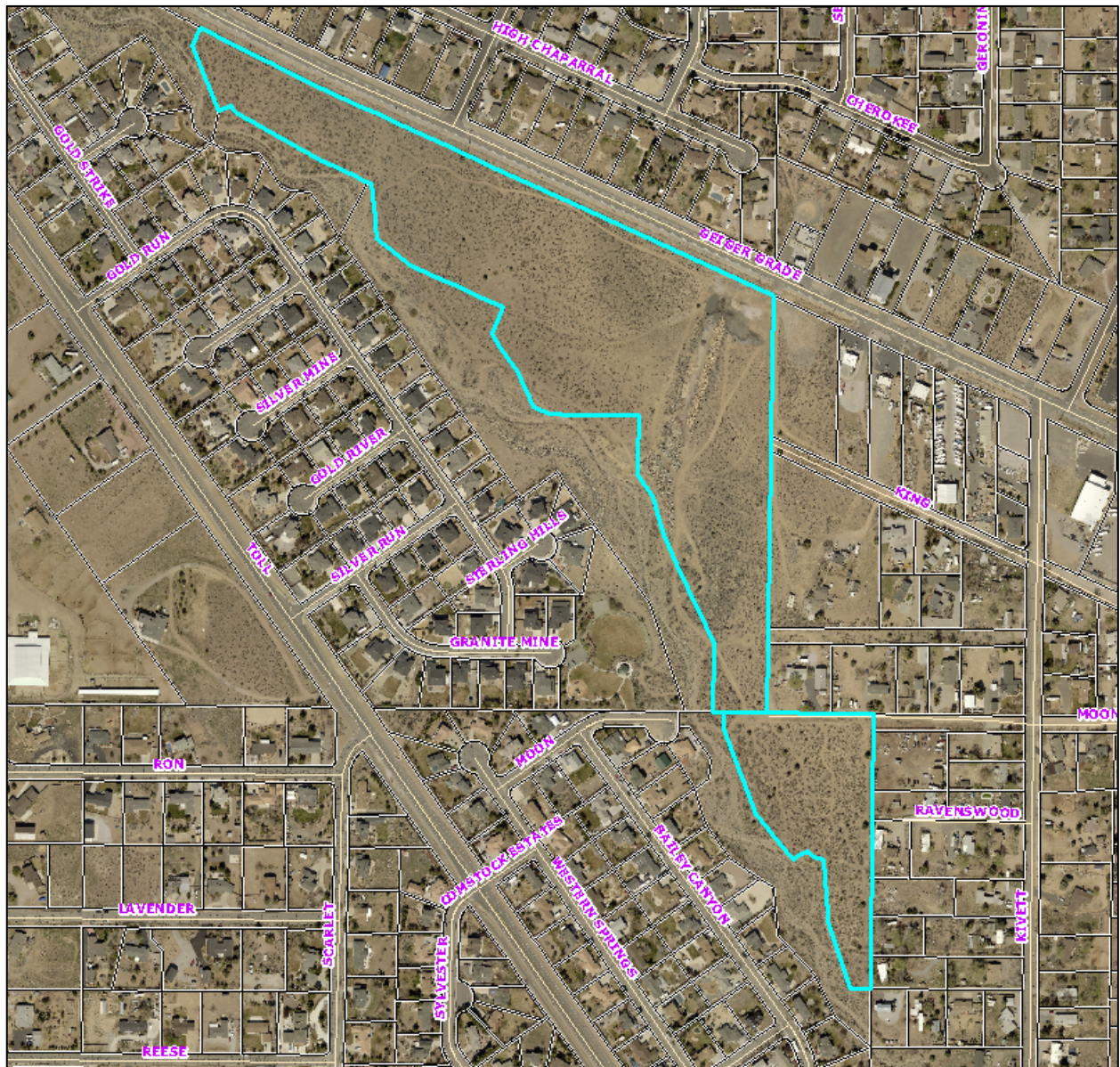

Photo: The project site (outlined in blue) is largely surrounded by other residential developments.

Washoe County Schools

The Washoe County School District (WCSD) anticipates the project to generate 14 new elementary school students, 3 middle school students and 7 high school students. The property is currently zoned for Brown Elementary School, Depoali Middle School and Damonte Ranch High School. WCSD has indicated that Brown Elementary School is operating at 137 percent of base capacity, Depoali Middle School at 94 percent of base capacity and Damonte Ranch High School at 108 percent of base capacity. Brown Elementary is scheduled to convert to a multi-track, year-round calendar for the 2017-18 school year. WCSD has stated that students from this development may be assigned to the closest schools with available capacity.

Traffic

The primary access to the project site is off of Geiger Grade, immediately opposite of Shadow Hills Drive. Gated emergency vehicle access will be provided off Moon Lane, which connects to

Kivett Lane. The project is anticipated to create 533 average daily trips, with 42 AM peak hour trips and 56 PM peak hour trips. The subdivision is below the threshold requiring a traffic impact report; however, the applicant did supply one as a courtesy to Washoe County for review. It is attached as Exhibit F.

The Washoe County Engineering and Capital Projects Division has provided several proposed standard conditions of approval related to traffic for the proposed development. These are included within Exhibit A. A deceleration lane will also be required along Geiger Grade to the entrance of the subdivision.

Grading and Drainage

The subject site is vacant and without significant topographic features. It is relatively level and slopes gently down from east to west. The Southeast Truckee Meadows Area Plan's Development Suitability Map identifies the property as being "most suitable" for development.

Currently, the parcels are largely undisturbed and contain significant native vegetation. The anticipated grading necessary to support the project involves the disturbance of approximately 29 acres, including the cut and fill of approximately 50,000 cubic yards of material to be balanced on site. The maximum allowable steepness for cut and fill within the development are 3:1 slopes.

Bailey Canyon Creek is located on adjacent property to the west of the project area. The northern parcel is largely FEMA Flood Zone X, with the southern parcel largely identified as Shaded X. Five common areas within the project boundaries are proposed for drainage and on-site detention. A preliminary drainage report was provided with the application and reviewed by the Engineering and Capital Projects Division. That division has provided several proposed conditions of approval related to drainage and stormwater discharge. The final design of the drainage system will need to ensure that the development has mitigated any increase in runoff, and that all storm drainage improvements are designed and constructed to Washoe County standards.

The continuing maintenance of common areas will be required to be addressed in the CC&Rs and funded in perpetuity through the homeowners' association.

Fire Protection

Fire protection services will be provided by the Truckee Meadows Fire Protection District (TMFPD). TMFPD has provided proposed conditions of approval related to overall development, open space and drainage area maintenance, access and turn-around widths. All development on the property will be required to comply with Washoe County Code Chapter 60.

Water and Sewer

The project is located within the Truckee Meadows Water Authority (TMWA) retail water service area, and TMWA will be the water service provider. An Acknowledgment of Water Service letter was provided to the applicant from TMWA and was included with the application. TMWA's provision of water will be contingent on the applicant satisfying a number of proposed conditions, including those identified in Exhibit A.

The State of Nevada's Division of Water Resources also reviewed the project and indicated that municipal water service is subject to TMWA requirements and approval by the Office of the State Engineer regarding water quantity and availability.

Sewer service will be provided by Washoe County and treatment will be at the South Truckee Meadows Water Reclamation Facility.

Relevant Southeast Truckee Meadows Area Plan Policies

SETM.2.2 The installation of new streetlights will be minimized and if approved will be for safety reasons. Any lighting proposed must show how it is consistent with current best practice “dark-sky” standards. Lights shall be shielded to prevent light spillage onto adjacent properties or streets.

Staff comment: A proposed condition of approval to this effect has been included with Exhibit A. Lighting will also be reviewed by the Design Review Committee, if this project is approved.

SETM.2.3 Site development plans for new subdivisions, commercial and public facilities in the Southeast Truckee Meadows planning area must submit and follow a plan for the control of noxious weeds. The plan should be developed through consultation with the Washoe County District Health Department, the University of Nevada Cooperative Extension, and/or the Washoe Story Conservation District.

Staff comment: A proposed condition of approval to this effect has been included with Exhibit A.

SETM.2.4 Applicants required to present their development proposal items to the Citizen Advisory Board must submit a statement to staff, not later than one week, following the meeting date, explaining how the final proposal responds to the community input received from the Citizen Advisory Board.

Staff comment: The South Truckee Meadows/Washoe Valley Citizen Advisory Board meeting will be held after this staff report is completed. However, the applicant’s statement will be provided to the Planning Commission prior to the February 7, 2017 hearing for this item.

SETM.2.5 During review of tentative maps and other development proposals, the Planning Commission will review the adequacy of the minimum standards established under Goals 2, 3, 4, and 5; and upon a finding that a standard is inadequate to implement these goals, may impose other similar standards as necessary to implement the relevant goal.

Staff comment: As discussed in this report, the proposed project meets (or there are proposed conditions for it to meet) the policies and goals of the Southeast Truckee Meadows Area Plan, including Goal 2. Goals 3, 4 and 5 are not applicable to the project site, as they provide guidance for other areas of the Southeast Truckee Meadows.

SETM.2.7 Dwellings in new subdivisions adjacent to existing residential development must match the adjacent building type (single story/multi-story). Development is considered adjacent if not separated by a road or a 30 foot or wider landscaped buffer area.

Staff comment: A proposed condition of approval to this effect has been included with Exhibit A.

SETM.2.8 New subdivision homebuilders must offer at least two separate xeriscape options for subdivision landscape design that emphasize the use of native vegetation, with non-native and atypical vegetation integrated sparingly into any landscaped area.

Staff comment: A proposed condition of approval to this effect has been included with Exhibit A. Landscaping will also be reviewed by the Design Review Committee if this project is approved.

SETM.2.13 Ensure that future residential development within the medium density suburban land use designation is constructed at a maximum of two single-family dwelling units per acre. Lot sizes shall not be less than one-third acre and this size may be allowed only under the following conditions:

- a. New subdivisions must provide one-half acre minimum lot sizes on exterior lots when abutting a developed medium density suburban land use designation with one-half acre or greater lot sizes (roads or open space do not create non-abutting parcels).
- b. Exterior lots may be reduced to one-third acre when abutting a developed higher intensity land use designation or a ten-acre or larger undeveloped medium density suburban designation.

Staff comment: The subdivision design meets the provisions of this policy. Exterior lots of 0.5-acres or more are proposed when adjacent to existing MDS lots of this size or greater. No other lots are smaller than 0.33-acres in size.

SETM.11.5 Soils disturbed through the development process and left untreated for more than 30 days shall be re-vegetated or treated in a manner to prevent the blowing of soil from the site by wind or the movement of soil by precipitation. Drought tolerant/fire resistant plant species should be used where appropriate.

Staff comment: A proposed condition of approval to this effect has been included with Exhibit A.

South Truckee Meadows/Washoe Valley Citizen Advisory Board (STM/WV CAB)

The proposed project will be presented by the applicant's representative at the STM/WV Citizen Advisory Board meeting on January 25, 2017. Draft minutes from the meeting will be provided to the Planning Commission prior to the February 7, 2017 hearing for this item.

As of the date of this staff report, two comment letters have been received from members of the public regarding this request. These are attached as Exhibit D.

Reviewing Agencies

The following agencies received a copy of the project application for review and evaluation:

- Washoe County Community Services Department
 - Engineering and Capital Projects Division
 - Planning and Development Division
 - Regional Parks and Open Space
 - Traffic
 - Utilities (Sewer)
- Nevada Division of Environmental Protection

- Nevada Division of Water Resources
- Nevada Department of Conservation and Natural Resources
- Nevada Department of Transportation
- Nevada Department of Wildlife
- Regional Transportation Commission
- Reno-Tahoe Airport Authority
- Truckee Meadows Fire Protection District
- Truckee Meadows Regional Planning Agency
- Truckee Meadows Water Authority
- United States Postal Service
- Washoe County Health District
 - Air Quality Management Division
 - Environmental Health Services Division
 - Vector-Borne Disease Prevention Program
 - Emergency Medical Services Oversight Program
- Washoe County School District
- Washoe-Storey Conservation District

Several of the above-listed agencies/departments submitted responses to the proposed tentative subdivision map. A summary of each agency's comments and/or recommended conditions of approval and their contact information are provided. The Conditions of Approval document is attached to this staff report and will be included with the Action Order should the Planning Commission approve the tentative subdivision map application.

- Washoe County Planning and Development Division addressed common area standards, lot sizes, structure heights, landscaping, CC&Rs, grading, timing of final map submittals, etc.
Contact: Kelly Mullin, 775.328.3608, kmullin@washoecounty.us
- Washoe County Engineering and Capital Projects Division addressed grading, drainage, stormwater management, maintenance of common area, easements, roadway improvements, etc.
Contact: Leo Vesely, 775.328.2313, lvesely@washoecounty.us
- Washoe County Utility Services requires improvement plans for construction of sanitary sewer collection system(s), sanitary sewer report, fees, and easements.
Contact: Tim Simpson, 775.954.4648, tsimpson@washoecounty.us
- Washoe County Health District addressed water system requirements, inspection plans, mass grading, commitment of service letters, etc.
Contact: Wes Rubio, 775.328.2635, wrubio@washoecounty.us
- Washoe County School District identified current and anticipated capacity at nearby schools, and highlighted the District's overcrowding strategies.
Contact: Mike Boster 775.232.1571, mboster@washoeschools.net
- Truckee Meadows Fire Protection District addressed requirements of Washoe County Code Chapter 60, including access, vegetation management and CC&R requirements.
Contact: Amy Ray, 775.326.6000, aray@fmfpd.us

- Truckee Meadows Water Authority (TMWA) identified requirements related to water rights dedication, a water supply plan, fees and infrastructure.
Contact: Amanda Duncan, 775.834.8035, aduncan@tmwa.com
- Nevada Division of Environmental Protection (NDEP) stated that the developer will need to obtain coverage under NDEP's Construction Stormwater Permit prior to any grading.
Contact: Patrick Mohn, 775.687.9419, pmohn@ndep.nv.gov
- Regional Transportation Commission (RTC) identified regional access management standards and requested the developer construct pedestrian and bicycle facilities, and contact the RTC to discuss options for future transit.
Contact: Rebecca Kapuler, 775.332.0174, rkapuler@rtcwashoe.com
- Nevada Division of Water Resources stated that water rights are required and that a will-serve letter from TMWA will be required.
Contact: Steve Shell, 775.684.2836, sshell@water.nv.gov
- Washoe County Regional Parks and Open Space and the Reno-Tahoe Airport Authority reviewed the application and indicated they had no comments or conditions of approval.

Staff Comment on Required Findings

Washoe County Code Section 110.608.25 requires that all of the following findings be made to the satisfaction of the Washoe County Planning Commission before granting approval of the request. Staff has completed an analysis of the application and has determined that the proposal is in compliance with the required findings as follows.

- 1) Plan Consistency. That the proposed map is consistent with the Master Plan and any specific plan.

Staff Comment: The proposed tentative map, with the proposed Conditions of Approval, meets all of the applicable goals and policies of the Washoe County Master Plan and the Southeast Truckee Meadows Area Plan. The subdivision design takes into consideration the policies of the Area Plan, including lot matching requirements.

- 2) Design or Improvement. That the design or improvement of the proposed subdivision is consistent with the Master Plan and any specific plan.

Staff Comment: The proposed tentative map meets all of the density, lot size and common open space criteria of the Washoe County Master Plan and the Southeast Truckee Meadows Area Plan. The proposed development complies with the two dwelling units per acre overall density allowed in the Medium Density Suburban (MDS) regulatory zone for this area. Parcel sizes smaller than MDS requirements are enabled through Article 408, Common Open Space Development, allowing for non-residential parcels to be created for drainage and retention facilities in this development.

- 3) Type of Development. That the site is physically suited for the type of development proposed.

Staff Comment: The site is a relatively level property adjacent to paved access, located in the midst of other residential subdivisions, and is suitable for a development with 56 dwellings. Lots are sized to match adjacent residential properties, and the design

complies with relevant area plan policies. The Area Plan's Development Suitability Map also identifies the property as being "most suitable" for development.

- 4) Availability of Services. That the subdivision will meet the requirements of Article 702, Adequate Public Facilities Management System.

Staff Comment: There are adequate public services available to serve the proposed development, specifically community sanitary sewer service.

- 5) Fish or Wildlife. That neither the design of the subdivision nor any proposed improvements is likely to cause substantial environmental damage, or substantial and avoidable injury to any endangered plant, wildlife or their habitat.

Staff Comment: The application was sent to the Nevada Department of Wildlife for review and no comments were received regarding the proposal. The proposed development is not located within an environmentally sensitive location, and the proposed improvements are not anticipated to cause substantial environmental damage or harm to endangered plants, wildlife or their habitat.

- 6) Public Health. That the design of the subdivision or type of improvement is not likely to cause significant public health problems.

Staff Comment: The design of the subdivision has been reviewed by the Health District and will comply with all generally applicable public health standards.

- 7) Easements. That the design of the subdivision or the type of improvements will not conflict with easements acquired by the public at large for access through, or use of property within, the proposed subdivision.

Staff Comment: The design of the subdivision includes primary and secondary (emergency vehicle) road access, pedestrian sidewalks and utility easements. Proposed conditions of approval regarding any existing/relocated easements have also been provided by the Engineering and Capital Projects Division.

- 8) Access. That the design of the subdivision provides any necessary access to surrounding, adjacent lands and provides appropriate secondary access for emergency vehicles.

Staff Comment: The design of the subdivision provides necessary access to surrounding adjacent lands and provides an appropriate secondary access for emergency vehicles via Moon Lane, which will be improved to County standards.

- 9) Dedications. That any land or improvements to be dedicated to the County is consistent with the Master Plan.

Staff Comment: Any improvements to be dedicated to the County are proposed or conditioned to be consistent with the Master Plan and County Code requirements.

- 10) Energy. That the design of the subdivision provides, to the extent feasible, for future passive or natural heating or cooling opportunities in the subdivision.

Staff Comment: The applicant has indicated that homes will be constructed using energy efficient design and will take water conservation into consideration. Additionally, Southeast Truckee Meadows Area Plan Policy 2.8 requires two various xeriscape landscape designs. These will be reviewed by the Design Review Committee if the project is approved.

Recommendation

Those agencies which reviewed the application recommended conditions in support of approval of the project. Therefore, after a thorough analysis and review, Tentative Subdivision Map Case Number WTM16-003 is being recommended for approval with conditions. Staff offers the following motion for the Board's consideration.

Motion

I move that, after giving reasoned consideration to the information contained in the staff report and information received during the public hearing, the Washoe County Planning Commission approve Tentative Subdivision Map Case Number WTM16-003 (Bailey Creek Estates) for Silver Crest Homes, with the Conditions of Approval included as Exhibit A to this matter, having made all ten findings in accordance with Washoe County Code Section 110.608.25:

- 1) Plan Consistency. That the proposed map is consistent with the Master Plan and any specific plan;
- 2) Design or Improvement. That the design or improvement of the proposed subdivision is consistent with the Master Plan and any specific plan;
- 3) Type of Development. That the site is physically suited for the type of development proposed;
- 4) Availability of Services. That the subdivision will meet the requirements of Article 702, Adequate Public Facilities Management System;
- 5) Fish or Wildlife. That neither the design of the subdivision nor any proposed improvements is likely to cause substantial environmental damage, or substantial and avoidable injury to any endangered plant, wildlife or their habitat;
- 6) Public Health. That the design of the subdivision or type of improvement is not likely to cause significant public health problems;
- 7) Easements. That the design of the subdivision or the type of improvements will not conflict with easements acquired by the public at large for access through, or use of property within, the proposed subdivision;
- 8) Access. That the design of the subdivision provides any necessary access to surrounding, adjacent lands and provides appropriate secondary access for emergency vehicles;
- 9) Dedications. That any land or improvements to be dedicated to the County is consistent with the Master Plan; and
- 10) Energy. That the design of the subdivision provides, to the extent feasible, for future passive or natural heating or cooling opportunities in the subdivision.

Appeal Process

Planning Commission action will be effective 10 calendar days after the written decision is filed with the Secretary to the Planning Commission, unless the action is appealed to the Washoe County Board of Commissioners, in which case the outcome of the appeal shall be determined by that Board. Any appeal must be filed in writing with the Planning and Development Division within 10 calendar days after the written decision is filed with the Secretary to the Planning Commission and mailed to the applicant.

xc: Applicant: Silver Crest Homes, Attn: Rich Balestreri, 16500 Wedge Parkway, Bldg. A, Suite 200, Reno, NV 89511

Property Owner: Charles Maddox, P.O. Box 70577, Reno, NV 89570

Representatives: Wood Rodgers, Attn: Stacie Huggins, 1361 Corporate Blvd., Reno, NV 89502

Wood Rodgers, Attn: Steve Strickland, 1361 Corporate Blvd., Reno, NV 89502



Conditions of Approval

Tentative Subdivision Map Case Number WTM16-003

The project approved under Tentative Subdivision Map Case Number WTM16-003 shall be carried out in accordance with the Conditions of Approval granted by the Planning Commission on February 7, 2017. Conditions of Approval are requirements placed on a permit or development by each reviewing agency. These Conditions of Approval may require submittal of documents, applications, fees, inspections, amendments to plans, and more. These conditions do not relieve the applicant of the obligation to obtain any other approvals and licenses from relevant authorities required under any other act or to abide by all other generally applicable Codes, and neither these conditions nor the approval by the County of this project/use override or negate any other applicable restrictions on uses or development on the property.

Unless otherwise specified, all conditions related to the approval of this Tentative Subdivision Map shall be met or financial assurance must be provided to satisfy the conditions of approval prior to issuance of a grading or building permit. The agency responsible for determining compliance with a specific condition shall determine whether the condition must be fully completed or whether the applicant shall be offered the option of providing financial assurance. All agreements, easements, or other documentation required by these conditions shall have a copy filed with the County Engineer and with the Planning and Development Division.

Compliance with the conditions of approval related to this Tentative Subdivision Map is the responsibility of the applicant, his/her successor in interest, and all owners, assignees, and occupants of the property and their successors in interest. Failure to comply with any of the conditions imposed in the approval of the Tentative Subdivision Map may result in the initiation of revocation procedures.

Washoe County reserves the right to review and revise the conditions of approval related to this Tentative Subdivision Map should it be determined that a subsequent license or permit issued by Washoe County violates the intent of this approval.

For the purpose of conditions imposed by Washoe County, “may” is permissive and “shall” or “must” is mandatory.

Conditions of Approval are usually complied with at different stages of the proposed project. Those stages are typically:

- Prior to recordation of a final map.
- Prior to obtaining a final inspection and/or a certificate of occupancy.
- Prior to the issuance of a business license or other permits/licenses.
- Some “Conditions of Approval” are referred to as “Operational Conditions.” These conditions must be continually complied with for the life of the project.

The Washoe County Commission oversees many of the reviewing agencies/departments with the exception of the following agencies.

- **The DISTRICT BOARD OF HEALTH, through the Washoe County Health District, has jurisdiction over all public health matters in the Health District. Any conditions set by the Health District must be appealed to the District Board of Health.**

- **The REGIONAL TRANSPORTATION COMMISSION (RTC) is directed and governed by its own Board. Conditions recommended by the RTC may be required, at the discretion of Washoe County.**
- **The NEVADA DEPARTMENT OF TRANSPORTATION (NDOT) is directed and governed by its own board. Therefore, any conditions set by the Nevada Department of Transportation must be appealed to that Board.**

STANDARD CONSIDERATIONS FOR SUBDIVISIONS
Nevada Revised Statutes 278.349

Pursuant to NRS 278.349, when contemplating action on a Tentative Subdivision Map, the governing body or the Planning Commission, if it is authorized to take final action on a tentative map, shall consider:

- (a) Environmental and health laws and regulations concerning water and air pollution, the disposal of solid waste, facilities to supply water, community or public sewage disposal and, where applicable, individual systems for sewage disposal;
- (b) The availability of water which meets applicable health standards and is sufficient for the reasonably foreseeable needs of the subdivision;
- (c) The availability and accessibility of utilities;
- (d) The availability and accessibility of public services such as schools, police and fire protection, transportation, recreation and parks;
- (e) Conformity with the zoning ordinances and master plan, except that if any existing zoning ordinance is inconsistent with the master plan, the zoning ordinance takes precedence;
- (f) General conformity with the governing body's master plan of streets and highways;
- (g) The effect of the proposed subdivision on existing public streets and the need for new streets and highways to serve the subdivision;
- (h) Physical characteristics of the land such as floodplain, slope and soil;
- (i) The recommendations and comments of those entities reviewing the tentative map pursuant to NRS 278.330 and 278.335; and
- (j) The availability and accessibility of fire protection, including, but not limited to, the availability and accessibility of water and services for the prevention and containment of fires, including fires in wild lands.

FOLLOWING ARE CONDITIONS OF APPROVAL REQUIRED BY THE REVIEWING AGENCIES. EACH CONDITION MUST BE MET TO THE SATISFACTION OF THE ISSUING AGENCY.

Washoe County Planning and Development Division

1. The following conditions are requirements of the Planning and Development Division, which shall be responsible for determining compliance with these conditions.

Contact: Kelly Mullin, 775.328.3608, kmullin@washoecounty.us

- a. The applicant shall demonstrate substantial conformance to the plans approved as part of this tentative subdivision map.
- b. Failure to comply with the conditions of approval shall render this approval null and void.
- c. The subdivision shall be in substantial conformance with the provisions of Washoe County Code Chapter 110, Article 408, *Common Open Space Development*, Article 604, *Design Requirements*, and Article 608, *Tentative Subdivision Maps*.
- d. Final maps and final construction drawings shall comply with all applicable statutes, ordinances, rules, regulations and policies in effect at the time of submittal of the tentative map or, if requested by the developer and approved by the applicable agency, those in effect at the time of approval of the final map.
- e. The subdivider shall present to Washoe County a final map, prepared in accordance with the tentative map, for the entire area for which a tentative map has been approved, or one of a series of final maps, each covering a portion of the approved tentative map, within four years after the date of approval of the tentative map or within two years of the date of approval for subsequent final maps. On subsequent final maps, that date may be extended by two years if the extension request is received prior to the expiration date.
- f. Final maps shall be in substantial compliance with all plans and documents submitted with and made part of this tentative map request, as may be amended by action of the final approving authority.
- g. All final maps shall contain the applicable portions of the following Jurat:

THE TENTATIVE MAP FOR WTM16-003 FOR BAILEY CREEK ESTATES WAS APPROVED BY THE WASHOE COUNTY PLANNING COMMISSION ON FEBRUARY 7, 2017.

THIS FINAL MAP, MAP NAME AND UNIT/PHASE #, MEETS ALL APPLICABLE STATUTES, ORDINANCES AND CODE PROVISIONS, IS IN SUBSTANTIAL CONFORMANCE WITH THE TENTATIVE MAP AND ITS CONDITIONS, WHICH ARE INCORPORATED HEREIN BY THIS REFERENCE, AND THOSE CONDITIONS HAVE BEEN SATISFIED FOR RECORDATION OF THIS MAP, EXCEPT THAT THE "OPERATIONAL CONDITIONS" CONTAINED IN THE RECORDED ACTION ORDER SHALL REMAIN IN FULL FORCE AND EFFECT IN PERPETUITY.

IF ALL LOTS ON THIS MAP ARE REVERTED TO ACREAGE AND A NEW SUBDIVISION APPROVAL IS OBTAINED AT A FUTURE DATE, THE PROVISIONS OF THIS APPROVAL SHALL

BE NULL AND VOID, UPON APPROVAL BY WASHOE COUNTY OF THOSE ACTIONS.

[Omit the following paragraph if this is the first and last (only) final map.]

THE FIRST FINAL MAP FOR THIS TENTATIVE MAP WAS APPROVED AND ACCEPTED FOR RECORDATION ON date of Planning and Development Director's signature on first final map. THE MOST RECENTLY RECORDED FINAL MAP WAS APPROVED AND ACCEPTED FOR RECORDATION ON date of Planning and Development Director's signature on most recent final map. [If an extension has been granted after that date – add the following]: A TWO YEAR EXTENSION OF TIME FOR THE TENTATIVE MAP WAS APPROVED BY THE WASHOE COUNTY PLANNING COMMISSION ON _____.

THE NEXT FINAL MAP FOR WTM16-003 MUST BE APPROVED AND ACCEPTED FOR RECORDATION BY THE PLANNING AND DEVELOPMENT DIRECTOR ON OR BEFORE THE EXPIRATION DATE, THE _____ DAY OF _____, 20____, OR AN EXTENSION OF TIME FOR THE TENTATIVE MAP MUST BE APPROVED BY THE WASHOE COUNTY PLANNING COMMISSION ON OR BEFORE SAID DATE.

THIS FINAL MAP IS APPROVED AND ACCEPTED FOR RECORDATION THIS _____ DAY OF _____, 20____ BY THE PLANNING AND DEVELOPMENT DIRECTOR. THE OFFER OF DEDICATION FOR STREETS, SEWERS, ETC. IS REJECTED AT THIS TIME, BUT WILL REMAIN OPEN IN ACCORDANCE WITH NRS CHAPTER 278.

WILLIAM H. WHITNEY, DIRECTOR,
PLANNING AND DEVELOPMENT DIVISION

- h. The applicant shall record the Action Order with the County Recorder. A copy of the recorded Action Order stating conditional approval of this tentative map shall be attached to all applications for administrative permits issued by Washoe County.
- i. A note shall be placed on all grading plans and construction drawings stating:

NOTE

Should any prehistoric or historic remains/artifacts be discovered during site development, work shall temporarily be halted at the specific site and the State Historic Preservation Office of the Department of Museums, Library and Arts shall be notified to record and photograph the site. The period of temporary delay

shall be limited to a maximum of two (2) working days from the date of notification.

- j. The final map shall designate faults that have been active during the Holocene epoch of geological time, and the final map shall contain the following note:

NOTE

No habitable structures shall be located on a fault that has been active during the Holocene epoch of geological time.

- k. The developer and all successors shall direct any potential purchaser of the site to meet with the Planning and Development Division to review conditions of approval prior to the final sale of the site. Any subsequent purchasers of the site shall notify the Planning and Development Division of the name, address, telephone number and contact person of the new purchaser within thirty (30) days of the final sale.
- l. Prior to any ground disturbing activity, the applicant shall submit a landscaping/architectural design plan to the Planning and Development Division for review and approval by the Design Review Committee. Said plan shall address, but not be limited to: signage, exterior lighting (including streetlights), fencing, landscaping design, landscaping material (if plant material: type, size at time of planting, maturation size at full growth, period of time between planting and full growth), landscaping location, landscaping irrigation system, and financial assurances that landscaping will be planted and maintained. At least two separate xeriscape options for subdivision landscape design shall be provided, emphasizing the use of native vegetation, with non-native and atypical vegetation integrated sparingly into any landscaped area.
- m. The applicant shall provide financial assurances to the Planning and Development Division equal to one hundred and twenty percent (120%) of the cost of revegetation and irrigation of all disturbed areas. The cost shall be calculated by a certified landscape contractor. The financial assurances are to be held with automatic renewal for not less than three years and are intended to ensure the continued survival of plants beyond that time period for mitigation of visual scarring and for erosion control. If the applicant chooses to provide a bond as financial assurance, it must be issued from an acceptable company rated A- or better. The applicant must also execute a Hold Harmless Agreement with right of entry. This condition must be completed to the satisfaction of the Planning and Development Division prior to issuance of a grading permit.
- n. A certification letter or series of letters by a registered landscape architect or other persons permitted to prepare landscaping and irrigation plans pursuant to NRS 623A shall be submitted to and approved by the Planning and Development Division and the Design Review Committee. The letter(s) shall certify that all applicable landscaping provisions of Articles 408, 410 and 412 of the Washoe County Code Chapter 110 (Development Code) have been met. Any landscaping plans and the letter shall be wet-stamped. The letter shall indicate any provisions of the code that the Director of the Planning and Development Division has waived.

- o. All landscaping and revegetation shall be maintained in accordance with the provisions found in Washoe County Code Section 110.412.75, Maintenance. A three-year maintenance plan shall be submitted by a licensed landscape architect registered in the State of Nevada to the Planning and Development Division prior to a Certificate of Occupancy. The plan shall be wet-stamped.
- p. The applicant shall submit and follow a plan for the control of noxious weeds. Prior to any ground-disturbing activity, the applicant shall provide the Planning and Development Division a copy of the plan, which should be developed through consultation with the Washoe County Health District, the University of Nevada Cooperative Extension, and/or the Washoe-Storey Conservation District.
- q. Any lighting proposed, including street lights, shall show how it is consistent with current best practice “dark-sky” standards and meets the requirements of Southeast Truckee Meadows Area Plan Policy 2.2. Lights shall be shielded to prevent light spillage onto adjacent properties or streets.
- r. Conditions, covenants, and restrictions (CC&Rs), including any supplemental CC&Rs, shall be submitted to the Planning and Development staff for review and subsequent forwarding to the District Attorney for review and approval. The final CC&Rs shall be signed and notarized by the owner(s) and submitted to the Planning and Development Division with the recordation fee prior to the recordation of the final map. The CC&Rs shall require all phases and units of the subdivision approved under this tentative map to be subject to the same CC&Rs. Washoe County shall be made a party to the applicable provisions of the CC&Rs to the satisfaction of the District Attorney’s Office. Said CC&Rs shall specifically address the potential for liens against the properties and the individual property owners’ responsibilities for the funding of maintenance, replacement, and perpetuation of the following items, at a minimum:
 - i. Maintenance of public access easements, common areas, and common open spaces. Provisions shall be made to monitor and maintain, for a period of three (3) years regardless of ownership, a maintenance plan for the common open space area. The maintenance plan for the common open space area shall, as a minimum, address the following:
 - Vegetation management;
 - Watershed management;
 - Debris and litter removal;
 - Fire access and suppression; and
 - Maintenance of public access and/or maintenance of limitations to public access.
 - ii. All drainage facilities and roadways not maintained by Washoe County shall be privately maintained and perpetually funded by the homeowners association.
 - iii. All open space identified as common area on the final map shall be privately maintained and perpetually funded by the homeowners association. The deed to the open space and common area shall reflect perpetual dedication for that purpose. The maintenance of the common

- areas and related improvements shall be addressed in the CC&Rs to the satisfaction of the District Attorney's Office.
- iv. The project adjacent to undeveloped land shall maintain a fire fuel break of a minimum 30 feet in width until such time as the adjacent land is developed.
 - v. Locating habitable structures on potentially active (Holocene) fault lines, whether noted on the recorded map or disclosed during site preparation, is prohibited.
 - vi. All outdoor lighting on buildings and streets within the subdivision shall be down-shielded.
 - vii. No motorized vehicles shall be allowed on the platted common area except emergency vehicles, utility service vehicles, or vehicles involved in homeowner association maintenance and repair of common area facilities.
 - viii. Mandatory solid waste collection.
 - ix. Fence material (if any), height, and location limitations, and re-fencing standards. Replacement fence must be compatible in materials, finish and location of existing fence.
 - x. Dwellings adjacent to existing residential development must match the adjacent building type (single story/multi-story). Development is considered adjacent if not separated by a road or a 30-foot or wider landscaped buffer area. A note to this effect shall be placed on applicable final maps, and a disclosure made by the developer to affected homebuyers on their closing documents.
- s. The common open space owned by the homeowners association shall be noted on the final map as "common open space" and the related deed of conveyance shall specifically provide for the preservation of the common open space in perpetuity. The deed to the open space and common area shall reflect perpetual dedication for that purpose. The deed shall be presented with the CC&Rs for review by the Planning and Development staff and the District Attorney.
 - t. Disturbed areas left undeveloped for more than thirty (30) days must be revegetated by methods approved by Planning and Development and that comply with the requirements of Southeast Truckee Meadows Area Plan Policy 11.5.
 - u. Construction hours are limited to 7 a.m. to 7 p.m., Monday through Saturday.
 - v. A will-serve from Truckee Meadows Water Authority and mylar map of the proposed project shall be presented to the State Engineer for approval and signed through his office prior to development.

Washoe County Engineering and Capital Projects Division

2. The following conditions are requirements of the Engineering and Capital Projects Division. Unless otherwise noted, the County Engineer shall be responsible for determining compliance with these conditions.

Contact: Leo Vesely, 775.328.2313, ivesely@washoecounty.us

General Conditions

- a. Final maps and final construction drawings shall comply with all applicable statutes, ordinances, rules, regulations, and policies in effect at the time of submittal of the tentative map or, if requested by the developer and approved by the applicable agency, those in effect at the time of approval of the final map.
- b. Prior to acceptance of public improvements and release of any financial assurances, the developer shall furnish to the water and sewer provider(s) and Engineering and Capital Projects Division a complete set of reproducible as-built construction drawings prepared by a civil engineer registered in the State of Nevada.
- c. The developer shall be required to participate in any applicable General Improvement District or Special Assessment District formed by Washoe County. The applicable County Department shall be responsible for determining compliance with this condition.
- d. The developer shall provide written approval from the U.S. Postal Service concerning the installation and type of mail delivery facilities. The system, other than individual mailboxes, must be shown on the project construction plans and installed as part of the onsite improvements.
- e. A complete set of construction improvement drawings, including an onsite grading plan, shall be submitted to the County Engineer for approval prior to finalization of any portion of the tentative map. Grading shall comply with best management practices (BMP's) and shall include detailed plans for grading and drainage on each lot, erosion control (including BMP locations and installation details), slope stabilization and mosquito abatement. Placement or disposal of any excavated material shall be indicated on the grading plan.
- f. All open space shall be identified as common area on the final map. A note on the final map shall indicate that all common areas shall be privately maintained and perpetually funded by the Homeowners Association. The County Engineer shall determine compliance with this condition. The maintenance of the common areas shall also be addressed in the CC&Rs to the satisfaction of the District Attorney's Office.
- g. Any existing easements or utilities that conflict with the development shall be relocated, quitclaimed, and/or abandoned, as appropriate.
- h. Any easement documents recorded for the project shall include an exhibit map that shows the location and limits of the easement in relationship to the project.
- i. All existing overhead utility lines shall be placed underground, except electric transmission lines greater than 100 kilovolts, which can remain above ground.

- j. With each affected final map, provide written approval from NV Energy for any improvements located within their easement or under their facilities.
- k. Appropriate easements shall be granted for any existing or new utilities, with each affected final map. This includes, but is not limited, to electrical lines, water lines, and drainage maintenance access.

Drainage and Storm Water Discharge Program Conditions (Washoe County Code Chapter 110, Articles 420 & 421)

- l. The conditional approval of this tentative map shall not be construed as final approval of the drainage facilities shown on the tentative map. Final approval of the drainage facilities will occur during the final map review and will be based upon the final hydrology report.
- m. Prior to finalization of the first final map, a master hydrology/hydraulic report and a master storm drainage plan shall be submitted to the County Engineer for approval.
- n. Prior to finalization of any portion of the tentative map, a final, detailed hydrology/hydraulic report for that unit shall be submitted to the County Engineer. All storm drainage improvements necessary to serve the project shall be designed and constructed to County standards and specifications and/or financial assurances in an appropriate form and amount shall be provided.
- o. Any increase in stormwater runoff resulting from the development and based on the 5-year and 100-year storm(s) shall be detained onsite, or off-site with necessary permission and easements from the property owner.
- p. Standard reinforced concrete headwalls or other approved alternatives shall be placed on the inlet and outlet of all drainage structures, and grouted rock riprap shall be used to prevent erosion at the inlets and outlets of all culverts to the satisfaction of the Engineering and Capital Projects Division.
- q. The developer shall provide pretreatment for petrochemicals and silt for all storm drainage leaving the site to the satisfaction of the Engineering and Capital Projects Division.
- r. The Truckee Meadows Regional Stormwater Quality Management Program Construction Permit Submittal Checklist and Inspection Fee shall be submitted with each final map.
- s. In medians with irrigated landscaping adjacent to the curb, a subdrain system shall be installed a minimum of one foot behind the back face of curb to intercept drainage from the landscaping. The system shall be tied to the storm drain system or an acceptable alternative drainage system.
- t. Drainage swales that drain more than two lots are not allowed to flow over the curb into the street; these flows shall be intercepted by an acceptable storm drain inlet and routed into the storm drain system.
- u. A note on the final map shall indicate that all drainage facilities not maintained by Washoe County shall be privately maintained and perpetually funded by a

homeowners association. As an alternative to a homeowners association, the developer may request the establishment of a County Utility Service Area under which fees would be paid for maintenance of the proposed storm drainage detention facility. The fee amount will be based on the additional service above that normally provided by the County to maintain new stormwater facilities dedicated by the developer (i.e., curb and gutter, drop inlets and piping). The County Engineer shall determine compliance with this condition. The maintenance and funding of these drainage facilities shall also be addressed in the CC&Rs to the satisfaction of the District Attorney's Office.

- v. The maximum permissible flow velocity (that which does not cause scour) shall be determined for all proposed channels and open ditches. The determination shall be based on a geotechnical analysis of the channel soil, proposed channel lining and channel cross section, and it shall be in accordance with acceptable engineering publications/calculations. Appropriate linings shall be provided for all proposed channels and open ditches such that the 100-year flows do not exceed the maximum permissible flow velocity.
- w. All slopes steeper than 3:1 shall be mechanically stabilized to control erosion. As an alternative to riprap, an engineered solution (geofabric, etc.) may be acceptable.
- x. Drainage easements shall be provided for all storm runoff that crosses more than one lot.
- y. Maintenance access roadways and drainage easements shall be provided for all existing and proposed drainage facilities. All drainage facilities located within Common Area shall be constructed with an adjoining minimum 12' wide gravel access road. Maintenance access road shall be provided to the bottom of proposed detention basins as well as over County owned and maintained storm drainage facilities.
- z. The FEMA 100-year floodplain shall be shown on the final map and grading plan to the satisfaction of the County Engineer. All grading in these areas shall be in conformance with the Washoe County Code Article 416.
- aa. Common Area or offsite drainage draining onto residential lots shall be perpetuated through or around residential lots and drainage facilities capable of passing a 100-year storm shall be constructed with the subdivision improvements to perpetuate the storm water runoff to improved or natural drainage facilities.
- bb. Prior to the finalization of any final map, provide verification that permission has been granted to construct Bailey Canyon Creek improvements on offsite parcels not owned by the applicant.
- cc. Drainage easements shall be recorded over all FEMA A zones and floodways.

Traffic and Roadway (Washoe County Code Chapter 110, Article 436)

- dd. All roadway improvements necessary to serve the project shall be designed and constructed to County standards and specifications and/or financial assurances in an appropriate form and amount shall be provided.

- ee. Street names shall be reviewed and approved by the Regional Street Naming Coordinator.
- ff. Proposed landscaping and/or fencing along street rights-of-way and within median islands shall be designed to meet American Association of State Highway and Transportation Officials (AASHTO) sight distances and safety guidelines. No tree shall overhang the curb line of any public street.
- gg. For any utilities placed in existing County streets, the streets shall be repaired to the satisfaction of the County Engineer. At a minimum, this will require full depth removal and replacement of asphalt for half the street width, or replacement of non-woven pavement reinforcing fabric with a 2" asphalt overlay for half the street width. Type II slurry seal is required for the entire street width with either option. Full width street improvements may be required if the proposed utility location is too close to the centerline of the existing street.
- hh. Streetlights shall be constructed to Washoe County standards at locations to be determined at the final design stage.
- ii. AASHTO clear zones shall be determined for all streets adjacent to retaining walls or slopes steeper than 3:1. If a recoverable or traversable clear zone cannot be provided, an analysis to determine if barriers are warranted shall be submitted for approval.
- jj. All retaining walls that are adjacent to, provide support for or retain soil from the County right-of-way shall be constructed of reinforced masonry block or reinforced concrete and designed by an engineer licensed in the State of Nevada.
- kk. No retaining walls that retain soil from the County right-of-way shall be located within a plowed snow storage easement.
- ll. Appropriate curve warning signs and/or a lower speed limit shall be determined and posted on all horizontal roadway curves that do not meet the standard Washoe County 25-mile per hour design speed. The minimum centerline radius allowed shall be 100'.
- mm. Appropriate transitions shall be provided between the existing and proposed improvements at all proposed street connections. This may include removal of existing pavement.
- nn. Access to parcels 017-053-01 & 02 from Moon Lane shall be perpetuated.
- oo. Any streetlights that do not meet Washoe County standards shall be placed outside Washoe County right-of-way. These streetlights shall be private, and the CC&R's shall indicate operation and maintenance of the streetlights shall be the responsibility of the Homeowners Association. The County Engineer and the District Attorney's Office shall determine compliance with this condition.
- pp. Provide a deceleration lane along the southern side of Geiger Grade (State Route 341) at the project entrance to the satisfaction of the County Engineer and NDOT.

- qq. An occupancy permit shall be obtained from NDOT for access to, from or under roads and highways maintained by NDOT, and a copy of the permit shall be submitted to the County Engineer prior to finalization of the affected final map.
- rr. A note on the final map shall state the no direct access from individual lots shall be allowed onto Geiger Grade or Shadow Hills Drive. This note shall also be included in the CC&Rs to the satisfaction of the District Attorney's office.
- ss. Prior to finalization of the any final map, provide written verification from NV Energy that proper clearances are maintained between the proposed improvements for Shadow Hills Drive and Moon Lane and the existing overhead power lines.

Washoe County Utilities

3. The following conditions are requirements of Washoe County Utilities, which shall be responsible for determining compliance with these conditions.

Contact: Tim Simpson, 775.954.4648, tsimpson@washoecounty.us

- a. All fees shall be paid or deferred in accordance with Washoe County Ordinance prior to the approval of each final map.
- b. Improvement plans shall be submitted and approved by CSD prior to approval of the final map. They shall be in compliance with Washoe County Design Standards and be designed by a Professional Engineer licensed to practice in the State of Nevada.
- c. The Applicant shall submit an electronic copy of the street and lot layout for each final map at initial submittal time. The files must be in a format acceptable to Washoe County.
- d. The Developer shall construct and/or provide the financial assurance for the construction of any on-site and off-site sanitary sewer collection systems prior to signature on each final map. The financial assurance must be in a form and amount acceptable to the CSD.
- e. Approved improvement plans shall be used for the construction of on-site and off-site sanitary sewer collection systems. The CSD will be responsible to inspect the construction of the sanitary sewer collection systems.
- f. The sanitary sewer collection systems must be offered for dedication to Washoe County along with the recordation of each final map.
- g. Easements and real property for all sanitary sewer collection systems and appurtenances shall be in accordance with Washoe County Design Standards and offered for dedication to Washoe County along with the recordation of each final map.
- h. A master sanitary sewer report for the entire tentative map shall be prepared and submitted by the applicant's engineer at the time of the initial submittal for the first final map which addresses:
 - i. the estimated sewage flows generated by this project;

- ii. projected sewage flows from potential or existing development within tributary areas;
 - iii. the impact on capacity of existing infrastructure;
 - iv. slope of pipe, invert elevation and rim elevation for all manholes; and
 - v. proposed collection line sizes, on-site and off-site alignment, and half-full velocities.
- i. No Certificate of Occupancy will be issued until all the sewer collection facilities necessary to serve each final map have been completed, accepted and completed as-built drawings delivered to the utility. As-built drawings must be in a format acceptable to Washoe County.
 - j. No permanent structures (including rockery or retaining walls, building's, etc.) shall be allowed within or upon any County maintained utility easement.
 - k. A minimum 30-foot wide sanitary sewer easement shall be dedicated to Washoe County over any sanitary sewer not located within the proposed right-of-way.
 - l. A minimum 12-foot wide all weather sanitary sewer access road shall be constructed to facilitate access to off-site sanitary sewer.
 - m. Any major infrastructure such as pump structures, controls, telemetry and appurtenances, lift stations, force mains, sewer mains and interceptors that are necessary to accommodate the project, the Developer will be responsible to fund the design and construction. However, the actual design will be the responsibility of the CSD. Prior to initiation of design the Developer shall pay the estimated design costs to Washoe County. The CSD may either provide such design in-house, or select an outside consultant. When an outside consultant is to be selected, the CSD and the Developer shall jointly select that consultant.
 - n. The CSD shall reserve the right to over-size the design of infrastructure to accommodate future development as determined by accepted engineering calculations. Funding shall be the responsibility of Washoe County. Washoe County shall either participate monetarily at the time of design and/or shall credit an appropriate dollar amount to the Developer at the time of recordation of the subdivision map.

Washoe County Health District

- 4. The following conditions are requirements of the Health District, which shall be responsible for determining compliance with these conditions. The District Board of Health has jurisdiction over all public health matters in the Health District. Any conditions set by the Health District must be appealed to the District Board of Health.

Contact: Wes Rubio, 775.328.2635, wrubio@washoecounty.us

The Environmental Health Services (EHS) Division requires the following conditions to be completed prior to review and approval of any Final Map:

- a. Prior to any final grading or other civil site improvements, a complete water system plan and Water Project submittal for the referenced proposal must be submitted to this Division. The plan must show that the water system will conform

to the State of Nevada Design, Construction, Operation and Maintenance Regulations for Public Water Systems, NAC Chapter 445A, and the State of Nevada Regulations Governing Review of Plans for Subdivisions, Condominiums, and Planned Unit Developments, NAC 278.400 and 278.410.

- i. The application for a Water Project shall conform to the requirements of NAC 445A.66695.
 - ii. Two copies of complete construction plans are required for review. All plans must include an overall site plan, additional phases that will eventually be built to indicate that the water system will be looped, all proposed final grading, utilities, and improvements for the proposed application.
- b. Mass grading may proceed after approval of the Tentative Map and after a favorable review by this Division of a grading permit application.
- i. The application shall include a Truckee Meadows Water Authority annexation and discovery with the mass grading permit.
- c. Improvement plans for the water system may be constructed prior to Final Map submittal only after Water Project approval by this Division.
- i. For improvement plans approved prior to Final Map submittal, the Developer shall provide certification by the Professional Engineer of record that the improvement plans were not altered subsequent to Final Map submittal.
 - ii. Any changes to previously approved improvement plans made prior to Final Map submittal shall be resubmitted to this Division for approval per NAC 278.290 and NAC 445A.66715.

The EHS Division requires the following to be submitted with the Final Map application for review and approval:

- d. Construction plans for the development must be submitted to this Division for approval. The construction drawings must conform to the State of Nevada Regulations Concerning Review of Plans for Subdivisions, Condominiums and Planned Unit Developments, and any applicable requirements of this Division.
- e. Prior to approval of a Final Map for the referenced project and pursuant to NAC 278.370, the developer must have the design engineer or a third person submit to the satisfaction this Division an inspection plan for periodic inspection of the construction of the systems for water supply and community sewerage. The inspection plan must address the following:
 - i. The inspection plan must indicate if an authorized agency, city or county is performing inspection of the construction of the systems for water supply and community sewerage.
 - ii. The design engineer or third person shall, pursuant to the approved inspection plan, periodically certify in writing to this Division that the improvements are being installed in accordance with the approved plans and recognized practices of the trade.

- iii. The developer must bear the cost of the inspections.
 - iv. The developer may select a third-person inspector but the selection must be approved by the Division or local agency. A third-person inspector must be a disinterested person who is not an employee of the developer.
 - v. A copy of the inspection plan must be included with the Final Map submittal.
- f. Prior to final approval, a “Commitment for Service” letter from the sewage purveyor committing sewer service for the entire proposed development must be submitted to this Division. The letter must indicate that the community facility for treatment will not be caused to exceed its capacity and the discharge permit requirements by this added service, or the facility will be expanded to provide for the added service.
- i. A copy of this letter must be included with the Final Map submittal.
- g. Prior to final approval, a “Commitment for Water Service” letter from the water purveyor committing adequate water service for the entire proposed development must be submitted to this Division.
- i. A copy of this letter must be included with the Final Map submittal.
- h. The Final Map application packet must include a letter from Nevada Division of Environmental Protection to this Division certifying their approval of the Final Map.
- i. The Final Map application packet must include a letter from Division of Water Resources certifying their approval of the Final Map.
- j. Pursuant to NAC 278.360 of the State of Nevada Regulations Governing Review of plans for Subdivision, Condominiums, and Planned Unit Developments, the development of the subdivision must be carried on in a manner which will minimize water pollution.
- i. Construction plans shall clearly show how the subdivision will comply with NAC 278.360.
- k. Prior to approval of the final map, the applicant must submit to this Division the Final Map fee.
- l. All grading and development activities must be in compliance with the DBOH Regulations Governing the Prevention of Vector-Borne Diseases.

Truckee Meadows Fire Protection District (TMFPD)

5. The following conditions are requirements of the Truckee Meadows Fire Protection District, which shall be responsible for determining compliance with these conditions.

Contact: Amy Ray, 775.326.6005, aray@tmfpd.us

- a. Plans shall be submitted for review and approval to TMFPD.

- b. Any developments on the property shall meet the requirements of Washoe County Code (WCC) Chapter 60.
- c. HOA and CC&R requirements and conditions shall be submitted for review, comment and approval by TMFPD prior to recording, adoption and use.
- d. Open spaces and drainages shall be maintained in accordance with WCC Chapter 60, the Vegetation Management Plan and conditions placed in the HOA and CC&R documents, ensuring vegetation management and maintenance in those areas.
- e. Two means of access and/or egress may be provided.
- f. Cul-de-sacs shall measure a minimum of 50-feet for radius and 100-feet for diameter.

Truckee Meadows Water Authority (TMWA)

- 6. The following conditions are requirements of the Truckee Meadows Water Authority, which shall be responsible for determining compliance with these conditions. TMWA is directed and governed by its own board. Therefore, any conditions set by TMWA must be appealed to that board.

Contact: Amanda Duncan, 775.834.8035, aduncan@tmwa.com

- a. Truckee Meadows Water Authority will require dedication of acceptable water resources, approval of the water supply plan by the local health authority, the execution of a Water Service Agreement, payment of TMWA fees, and the construction and dedication of infrastructure in accordance with TMWA rules and tariffs in effect at the time of application for service.

*** End of Conditions ***



Washoe County

COMMUNITY SERVICES DEPARTMENT

Engineering and Capital Projects Division

Date: January 13, 2017

To: Kelly Mullin, Planning and Development Division

From: Leo R. Vesely, P.E., Engineering and Capitol Projects Division

Re: **WTM16-003**
APN 017-520-03
Bailey Creek Estates Subdivision (56 Lots)

Recommended Conditions of Approval

The following conditions of approval should be applied to this proposed project. Conditions in italics are standard Engineering Conditions.

GENERAL CONDITIONS

- Final maps and final construction drawings shall comply with all applicable statutes, ordinances, rules, regulations, and policies in effect at the time of submittal of the tentative map or, if requested by the developer and approved by the applicable agency, those in effect at the time of approval of the final map.*
- Prior to acceptance of public improvements and release of any financial assurances, the developer shall furnish to the water and sewer provider(s) and Engineering and Capital Projects Division a complete set of reproducible as-built construction drawings prepared by a civil engineer registered in the State of Nevada.*
- The developer shall be required to participate in any applicable General Improvement District or Special Assessment District formed by Washoe County. The applicable County Department shall be responsible for determining compliance with this condition.*
- The developer shall provide written approval from the U.S. Postal Service concerning the installation and type of mail delivery facilities. The system, other than individual mailboxes, must be shown on the project construction plans and installed as part of the onsite improvements. The County Engineer shall determine compliance with this condition.*
- A complete set of construction improvement drawings, including an onsite grading plan, shall be submitted to the County Engineer for approval prior to finalization of any portion of the tentative map. Grading shall comply with best management practices (BMP's) and shall include detailed plans for grading and drainage on each lot, erosion control (including BMP locations and installation details), slope stabilization and mosquito abatement. Placement or disposal of any excavated material shall be indicated on the grading plan. The County Engineer shall determine compliance with this condition.*
- All open space shall be identified as common area on the final map. A note on the final map shall indicate that all common areas shall be privately maintained and perpetually funded by the Homeowners Association. The County Engineer shall determine compliance with this condition.*

The maintenance of the common areas shall also be addressed in the CC&Rs to the satisfaction of the District Attorney's Office.

- 7. Any existing easements or utilities that conflict with the development shall be relocated, quitclaimed, and/or abandoned, as appropriate. The County Engineer shall determine compliance with this condition.*
- 8. Any easement documents recorded for the project shall include an exhibit map that shows the location and limits of the easement in relationship to the project. The County Engineer shall determine compliance with this condition.*
- 9. All existing on-site overhead utility lines shall be placed underground, except electric transmission lines greater than 100 kilovolts, which can remain above ground. The County Engineer shall determine compliance with this condition.*
- 10. With each affected final map, provide written approval from NV Energy for any improvements located within their easement or under their facilities. The County Engineer shall determine compliance with this condition.*
- 11. Appropriate easements shall be granted for any existing or new utilities, with each affected final map. This includes, but is not limited, to electrical lines, water lines, and drainage maintenance access. The County Engineer shall determine compliance with this condition.*

**DRAINAGE and STORM WATER DISCHARGE PROGRAM
(COUNTY CODE 110.420 and 110.421)**

The following are drainage conditions of approval:

- 1. The conditional approval of this tentative map shall not be construed as final approval of the drainage facilities shown on the tentative map. Final approval of the drainage facilities will occur during the final map review and will be based upon the final hydrology report.*
- 2. Prior to finalization of the first final map, a master hydrology/hydraulic report and a master storm drainage plan shall be submitted to the County Engineer for approval. The County Engineer shall determine compliance with this condition.*
- 3. Prior to finalization of any portion of the tentative map, a final, detailed hydrology/hydraulic report for that unit shall be submitted to the County Engineer. All storm drainage improvements necessary to serve the project shall be designed and constructed to County standards and specifications and/or financial assurances in an appropriate form and amount shall be provided. The County Engineer shall determine compliance with this condition.*
- 4. Any increase in stormwater runoff resulting from the development and based on the 5 year and 100 storm(s) shall be detained onsite, or off-site with necessary permission and easements from the property owner. The County Engineer shall determine compliance with this condition.*
- 5. Standard reinforced concrete headwalls or other approved alternatives shall be placed on the inlet and outlet of all drainage structures, and grouted rock riprap shall be used to prevent erosion at the inlets and outlets of all culverts to the satisfaction of the Engineering and Capital Projects Division.*
- 6. The developer shall provide pretreatment for petrochemicals and silt for all storm drainage leaving the site to the satisfaction of the Engineering and Capital Projects Division.*
- 7. The Truckee Meadows Regional Stormwater Quality Management Program Construction Permit Submittal Checklist and Inspection Fee shall be submitted with each final map. The County Engineer shall determine compliance with this condition.*
- 8. In medians with irrigated landscaping adjacent to the curb, a subdrain system shall be installed a minimum of one foot behind the back face of curb to intercept drainage from the landscaping. The*

system shall be tied to the storm drain system or an acceptable alternative drainage system. The County Engineer shall determine compliance with this condition.

9. *Drainage swales that drain more than two lots are not allowed to flow over the curb into the street; these flows shall be intercepted by an acceptable storm drain inlet and routed into the storm drain system. The County Engineer shall determine compliance with this condition.*
10. *A note on the final map shall indicate that all drainage facilities not maintained by Washoe County shall be privately maintained and perpetually funded by a homeowners association. As an alternative to a homeowners association, the developer may request the establishment of a County Utility Service Area under which fees would be paid for maintenance of the proposed storm drainage detention facility. The fee amount will be based on the additional service above that normally provided by the County to maintain new stormwater facilities dedicated by the developer (i.e., curb and gutter, drop inlets and piping). The County Engineer shall determine compliance with this condition. The maintenance and funding of these drainage facilities shall also be addressed in the CC&Rs to the satisfaction of the District Attorney's Office.*
11. *The maximum permissible flow velocity (that which does not cause scour) shall be determined for all proposed channels and open ditches. The determination shall be based on a geotechnical analysis of the channel soil, proposed channel lining and channel cross section, and it shall be in accordance with acceptable engineering publications/calculations. Appropriate linings shall be provided for all proposed channels and open ditches such that the 100-year flows do not exceed the maximum permissible flow velocity. The County Engineer shall determine compliance with this condition.*
12. *All slopes steeper than 3:1 shall be mechanically stabilized to control erosion. As an alternative to riprap, an engineered solution (geofabric, etc.) may be acceptable. The County Engineer shall determine compliance with this condition.*
13. *Drainage easements shall be provided for all storm runoff that crosses more than one lot. The County Engineer shall determine compliance with this condition.*
14. **Maintenance access roadways and drainage easements shall be provided for all existing and proposed drainage facilities. All drainage facilities located within Common Area shall be constructed with an adjoining minimum 12' wide gravel access road. Maintenance access road shall be provided to the bottom of proposed detention basins as well as over County owned and maintained storm drainage facilities. County Engineer shall determine compliance with this condition.**
15. **The FEMA 100-year floodplain shall be shown on the final map and grading plan to the satisfaction of the County Engineer. All grading in these areas shall be in conformance with the Washoe County Code Article 416.**
16. **Common Area or offsite drainage draining onto residential lots shall be perpetuated through or around residential lots and drainage facilities capable of passing a 100-year storm shall be constructed with the subdivision improvements to perpetuate the storm water runoff to improved or natural drainage facilities. The County Engineer shall determine compliance with this condition.**
17. **Prior to the finalization of any final map, provide verification that permission has been granted to construct Bailey Canyon Creek improvements on offsite parcels not owned by the applicant. The County Engineer shall determine compliance with this condition.**
18. **Drainage easements shall be recorded over all FEMA A zones and floodways. The County Engineer shall determine compliance with this condition.**

TRAFFIC AND ROADWAY (COUNTY CODE 110.436)

1. *All roadway improvements necessary to serve the project shall be designed and constructed to County standards and specifications and/or financial assurances in an appropriate form and amount shall be provided. The County Engineer shall determine compliance with this condition.*
2. *Street names shall be reviewed and approved by the Regional Street Naming Coordinator.*
3. *Proposed landscaping and/or fencing along street rights-of-way and within median islands shall be designed to meet American Association of State Highway and Transportation Officials (AASHTO) sight distances and safety guidelines. No tree shall overhang the curb line of any public street. The County Engineer shall determine compliance with this condition.*
4. *For any utilities placed in existing County streets, the streets shall be repaired to the satisfaction of the County Engineer. At a minimum, this will require full depth removal and replacement of asphalt for half the street width, or replacement of non-woven pavement reinforcing fabric with a 2" asphalt overlay for half the street width. Type II slurry seal is required for the entire street width with either option. Full width street improvements may be required if the proposed utility location is too close to the centerline of the existing street.*
5. *Streetlights shall be constructed to Washoe County standards at locations to be determined at the final design stage. The County Engineer shall determine compliance with this condition.*
6. *AASHTO clear zones shall be determined for all streets adjacent to retaining walls or slopes steeper than 3:1. If a recoverable or traversable clear zone cannot be provided, an analysis to determine if barriers are warranted shall be submitted for approval. The County Engineer shall determine compliance with this condition.*
7. *All retaining walls that are adjacent to, provide support for or retain soil from the County right-of-way shall be constructed of reinforced masonry block or reinforced concrete and designed by an engineer licensed in the State of Nevada. The County Engineer shall determine compliance with this condition.*
8. *No retaining walls that retain soil from the County right-of-way shall be located within a plowed snow storage easement. The County Engineer shall determine compliance with this condition.*
9. *With Appropriate curve warning signs and/or a lower speed limit shall be determined and posted on all horizontal roadway curves that do not meet the standard Washoe County 25-mile per hour design speed. The minimum centerline radius allowed shall be 100'. The County Engineer shall determine compliance with this condition.*
10. *Appropriate transitions shall be provided between the existing and proposed improvements at all proposed street connections. This may include removal of existing pavement. The County Engineer shall determine compliance with this condition.*
11. *Access to parcels 017-053-01 & 02 from Moon Lane shall be perpetuated. The County Engineer shall determine compliance with this condition.*
12. *Any streetlights that do not meet Washoe County standards shall be placed outside Washoe County right-of-way. These streetlights shall be private, and the CC&R's shall indicate operation and maintenance of the streetlights shall be the responsibility of the Homeowners Association. The County Engineer and the District Attorney's Office shall determine compliance with this condition.*
13. *Provide a deceleration lane on Geiger Grade (State Route 341) at the project entrance to the satisfaction of the County Engineer and NDOT.*
14. *An occupancy permit shall be obtained from NDOT for access to, from or under roads and highways maintained by NDOT, and a copy of the permit shall be submitted to the County Engineer prior to finalization of the affected final map.*

15. A note on the final map shall state the no direct access from individual lots shall be allowed onto Geiger Grade or Shadow Hills Drive. County Engineer shall determine compliance with this condition. This note shall also be included in the CC&Rs to the satisfaction of the District Attorney's office.
16. Prior to finalization of the any final map, provide written verification from NV Energy that proper clearances are maintained between the proposed improvements for Shadow Hills Drive and Moon Lane and the existing overhead power lines. The County Engineer shall determine compliance with this condition.



Washoe County
COMMUNITY SERVICES DEPARTMENT
Engineering and Capital Projects

January 6, 2017

To: Kelly Mullin, Community Development
From: Timothy Simpson, P.E., Environmental Engineer II
CC: Dwayne Smith, P.E., Division Director Eng & Cap Projects
Subject: WTM16-003 Bailey Creek Estates; 017-520-03 and 017-480-02

The Community Services Department (CSD) has reviewed the subject application and has the following comments:

1. The applicant is proposing to develop a 56-lot residential subdivision. The project is located off Geiger Grade Road and Shadow Hills Drive.
2. Sanitary sewer will be provided by Washoe County and treatment will be at the South Truckee Meadows Water Reclamation Facility.

The Community Services Department (CSD) recommends approval provided the following conditions are met:

1. All fees shall be paid or deferred in accordance with Washoe County Ordinance prior to the approval of each final map.
2. Improvement plans shall be submitted and approved by CSD prior to approval of the final map. They shall be in compliance with Washoe County Design Standards and be designed by a Professional Engineer licensed to practice in the State of Nevada.
3. The Applicant shall submit an electronic copy of the street and lot layout for each final map at initial submittal time. The files must be in a format acceptable to Washoe County.
4. The Developer shall construct and/or provide the financial assurance for the construction of any on-site and off-site sanitary sewer collection systems prior to signature on each final map. The financial assurance must be in a form and amount acceptable to the CSD.
5. Approved improvement plans shall be used for the construction of on-site and off-site sanitary sewer collection systems. The CSD will be responsible to inspect the construction of the sanitary sewer collection systems.
6. The sanitary sewer collection systems must be offered for dedication to Washoe County along with the recordation of each final map.

7. Easements and real property for all sanitary sewer collection systems and appurtenances shall be in accordance with Washoe County Design Standards and offered for dedication to Washoe County along with the recordation of each final map.
8. A master sanitary sewer report for the entire tentative map shall be prepared and submitted by the applicant's engineer at the time of the initial submittal for the first final map which addresses:
 - a. the estimated sewage flows generated by this project,
 - b. projected sewage flows from potential or existing development within tributary areas,
 - c. the impact on capacity of existing infrastructure,
 - d. slope of pipe, invert elevation and rim elevation for all manholes,
 - e. proposed collection line sizes, on-site and off-site alignment, and half-full velocities.
9. No Certificate of Occupancy will be issued until all the sewer collection facilities necessary to serve each final map have been completed, accepted and completed as-built drawings delivered to the utility. As-built drawings must be in a format acceptable to Washoe County.
10. No permanent structures (including rockery or retaining walls, building's, etc.) shall be allowed within or upon any County maintained utility easement.
11. A minimum 30-foot wide sanitary sewer easement shall be dedicated to Washoe County over any sanitary sewer not located within the proposed right-of-way.
12. A minimum 12-foot wide all weather sanitary sewer access road shall be constructed to facilitate access to off-site sanitary sewer.
13. Any major infrastructure such as pump structures, controls, telemetry and appurtenances, lift stations, force mains, sewer mains and interceptors that are necessary to accommodate the project, the Developer will be responsible to fund the design and construction. However, the actual design will be the responsibility of the CSD. Prior to initiation of design the Developer shall pay the estimated design costs to Washoe County. The CSD may either provide such design in-house, or select an outside consultant. When an outside consultant is to be selected, the CSD and the Developer shall jointly select that consultant.
14. The CSD shall reserve the right to over-size the design of infrastructure to accommodate future development as determined by accepted engineering calculations. Funding shall be the responsibility of Washoe County. Washoe County shall either participate monetarily at the time of design and/or shall credit an appropriate dollar amount to the Developer at the time of recordation of the subdivision map.

WASHOE COUNTY
HEALTH DISTRICT
ENHANCING QUALITY OF LIFE

January 6, 2017

Kelly Mullin, Planner
Washoe County Community Services
Planning and Development Division
PO Box 11130
Reno, NV 89520-0027

RE: Bailey Creek Estates; APN 017-520-03 & 017-480-02
Tentative Subdivision Map; WTM16-003

Dear Ms. Mullin:

The Washoe County Health District, Environmental Health Services Division (Division) Engineering has reviewed the above referenced project. Approval by this Division is subject to the following conditions:

Tentative Map Review and Final Map Conditions per NAC 278

This Division requires the following conditions to be completed prior to review and approval of any Final Map:

1. Prior to any final grading or other civil site improvements, a complete water system plan and Water Project submittal for the referenced proposal must be submitted to this Division. The plan must show that the water system will conform to the State of Nevada Design, Construction, Operation and Maintenance Regulations for Public Water Systems, NAC Chapter 445A, and the State of Nevada Regulations Governing Review of Plans for Subdivisions, Condominiums, and Planned Unit Developments, NAC 278.400 and 278.410.
 - a. The application for a Water Project shall conform to the requirements of NAC 445A.66695.
 - b. Two copies of complete construction plans are required for review. All plans must include an overall site plan, additional phases that will eventually be built to indicate that the water system will be looped, all proposed final grading, utilities, and improvements for the proposed application.
2. Mass grading may proceed after approval of the Tentative Map and after a favorable review by this Division of a grading permit application.
 - a. The application shall include a Truckee Meadows Water Authority annexation and discovery with the mass grading permit.
3. Improvement plans for the water system may be constructed prior to Final Map submittal only after Water Project approval by this Division.
 - a. For improvement plans approved prior to Final Map submittal, the Developer shall provide certification by the Professional Engineer of record that the improvement plans were not altered subsequent to Final Map submittal.

- b. Any changes to previously approved improvement plans made prior to Final Map submittal shall be resubmitted to this Division for approval per NAC 278.290 and NAC 445A.66715.

This Division requires the following to be submitted with the Final Map application for review and approval:

1. Construction plans for the development must be submitted to this Division for approval. The construction drawings must conform to the State of Nevada Regulations Concerning Review of Plans for Subdivisions, Condominiums and Planned Unit Developments, and any applicable requirements of this Division.
2. Prior to approval of a Final Map for the referenced project and pursuant to NAC 278.370, the developer must have the design engineer or a third person submit to the satisfaction this Division an inspection plan for periodic inspection of the construction of the systems for water supply and community sewerage. The inspection plan must address the following:
 - a. The inspection plan must indicate if an authorized agency, city or county is performing inspection of the construction of the systems for water supply and community sewerage.
 - b. The design engineer or third person shall, pursuant to the approved inspection plan, periodically certify in writing to this Division that the improvements are being installed in accordance with the approved plans and recognized practices of the trade.
 - c. The developer must bear the cost of the inspections.
 - d. The developer may select a third-person inspector but the selection must be approved by the Division or local agency. A third-person inspector must be a disinterested person who is not an employee of the developer.
 - e. A copy of the inspection plan must be included with the Final Map submittal.
3. Prior to final approval, a "Commitment for Service" letter from the sewage purveyor committing sewer service for the entire proposed development must be submitted to this Division. The letter must indicate that the community facility for treatment will not be caused to exceed its capacity and the discharge permit requirements by this added service, or the facility will be expanded to provide for the added service.
 - a. A copy of this letter must be included with the Final Map submittal.
4. Prior to final approval, a "Commitment for Water Service" letter from the water purveyor committing adequate water service for the entire proposed development must be submitted to this Division.
 - a. A copy of this letter must be included with the Final Map submittal.
5. The Final Map application packet must include a letter from Nevada Division of Environmental Protection to this Division certifying their approval of the Final Map.
6. The Final Map application packet must include a letter from Division of Water Resources certifying their approval of the Final Map.
7. Pursuant to NAC 278.360 of the State of Nevada Regulations Governing Review of plans for Subdivision, Condominiums, and Planned Unit Developments, the development of the subdivision must be carried on in a manner which will minimize water pollution.
 - a. Construction plans shall clearly show how the subdivision will comply with NAC 278.360.
8. Prior to approval of the final map, the applicant must submit to this Division the Final Map fee.
9. All grading and development activities must be in compliance with the DBOH Regulations Governing the Prevention of Vector-Borne Diseases.

01/06/2017
Bailey Creek Estates; APN 017-520-03 & 017-480-02
Tentative Subdivision Map; WTM16-003
Page 3

If you have any questions or would like clarification regarding the foregoing, please contact Wes Rubio, Senior Environmental Health Specialist at wrubio@washoecounty.us regarding all Health District comments.

Sincerely,

A handwritten signature in cursive script that reads "Bob Sack".

Bob Sack, Division Director
Environmental Health Services Division
Washoe County Health District

BS:wr

Cc: File - Washoe County Health District



Washoe County School District

Every Child, By Name And Face, To Graduation

425 East Ninth Street * P.O. Box 30425 * Reno, NV 89520-3425

Phone (775) 348-0200 * (775) 348-0304 * www.washoeschools.net

Board of Trustees: Angela Taylor, President * John Mayer, Vice President * Veronica Frankel, Clerk *
Howard Rosenberg * Lisa Ruggiero * Ryan Gonda * Diane Nicolet * Traci Davis, Superintendent

3 January, 2017

Kelly Mullin, Planner
Washoe County Planning and Development Division, Community Services Dept.
P.O. Box 11130
Reno, NV 89520-0027

RE: CASE NUMBER: WTM16-003 (Bailey Creek Estates)

Dear Ms. Mullin,

56 new single-family residential units will impact Washoe County School District facilities. This project is currently zoned for the following schools:

Brown Elementary School

- **Estimated project impact = 14** new ES students (**56** single-family units x **.244** ES students per unit)
- **Base Capacity = 638**
- **2016-2017 Enrollment = 877**
- **% of Base Capacity = 137%**
- **2016-2017 Enrollment with Bailey Creek Estates = 891**
- **% of Base Capacity with Bailey Creek Estates = 140%**
- **Overcrowding Strategies:**
 - **Brown ES** has **5** portable buildings (**10** classrooms) in use that provide temporary space for an additional **250** students.
 - Brown ES will convert to a multi-track, year-round (MTYR) calendar for the 2017-2018 school year in accordance with WCSD Policy 6111.
 - Assignment to the closest elementary school with available capacity may be used for students in this development.

Depoali Middle School

- **Estimated project impact** = 3 new MS students (56 single-family units x .063 MS students per unit)
- **Base Capacity** = 1,320
- **2016-2017 Enrollment** = 1,247
- **% of Base Capacity** = 94%
- **2016-2017 Enrollment with Bailey Creek Estates** = 1,250
- **% of Base Capacity with Bailey Creek Estates** = 95%
- **Overcrowding Strategies:**
 - The **Depoali** MS property may be able to accommodate portable classrooms if necessary and if funding for the units is available.
 - Per adopted District Policy 6111, most middle schools will be converted to a double session^b calendar when enrollment exceeds 120% of capacity.
 - Assignment to the closest middle school with available capacity may be used for students in this development.

Damonte Ranch High School

- **Estimated project impact** = 7 new HS students (56 single-family units x .121 HS students per unit)
- **Base Capacity** = 1,597
- **2016-2017 Enrollment** = 1,723
- **% of Base Capacity** = 108%
- **2016-2017 Enrollment with Bailey Creek Estates** = 1,730
- **% of Base Capacity with Bailey Creek Estates** = 108%
- **Overcrowding Strategies:**
 - **Damonte Ranch** HS has 4 portable units (8 classrooms) in place that provide temporary space for an additional 200 students.
 - Per adopted District Policy 6111, high schools will convert to a double session calendar^b when enrollment exceeds 120% of capacity.
 - Assignment to the closest high school with available capacity may be implemented for students in this development.

With the passage of Washoe County Question 1, the Washoe County School District now has sustainable, adequate funding for building and repairing schools (“capital” funding). Here are the three things to know as we move forward with using this funding to address overcrowding and repairs:

1. **Overcrowding and needed repairs will be addressed as quickly as possible, but solutions will take time.** The District’s problems with overcrowding and backlogged repair needs are the result of more than a decade without adequate capital funding, and will not be solved overnight.
 - o We should be able to avoid Double Sessions at middle and high schools.
 - o We cannot avoid Multi-Track at the elementary level, but will work to eliminate it as quickly as possible.
2. **We want to hear from you.** Capital projects must first be approved by an independent group of community members, and only then go to the school district’s Board of Trustees. All discussions take place in open, public meetings. The community is invited and encouraged to attend these meetings and give input there, through our online form, or by contacting Riley Sutton, our community outreach person on these issues, at 348-0278 or rsutton@washoeschools.net.
3. **Transparency is a top priority.** Past spending and future projects are posted on our Data Gallery (<http://datagallery.washoeschools.net/>). Capital projects follow the public bidding process, which can also be viewed there. We will continue to develop these tools as we go forward to further engage the public in the work we are doing. If you have an idea for other information you would like us to present or ways we could better present current information, please let us know

Definitions:

- a) **Multi-Track Year-Round Calendar (MTYR):** The school is divided into four groups (“tracks”) which start and end the school year on different dates, with only three tracks attending school at any one time. This can decrease overcrowding by as much as 25%.
- b) **Double Sessions:** Two “schools” are operated out of one building; the school is divided into two separate groups which start and end the day at different times, with no overlap. Double Sessions have not been done in WCSD for over 30 years; all details are still in process in terms of exact start and end times, division of the school, and more. Other school districts in Nevada, which have more recent experience with Double Sessions, ran the first high school session from 5:55am to 11:55am and the second session ran from approximately 12:00 p.m. to 6:00 p.m. Double Sessions can relieve overcrowding by as much as 50%.

Thank you for the opportunity to comment.



Mike Boster
School Planner
14101 Old Virginia Road
Reno NV USA 89521
[Washoe County School District Capital Projects](#)
775.789.3810
mboster@washoeschools.net

From: Duncan, Amanda
To: [Mullin, Kelly](#)
Cc: [Zimmerman, John](#)
Subject: RE: December Agency Review Memo IV (WTM 16-003) Bailey Creek Estates
Date: Thursday, January 05, 2017 8:45:12 AM

Kelly,

Good Morning. TMWA has the following condition to apply to this project.

Truckee Meadows Water Authority (TMWA) will require dedication of acceptable water resources, approval of the water supply plan by the local health authority, the execution of a Water Service Agreement, payment of TMWA fees, and the construction and dedication of infrastructure in accordance with TMWA rules and tariffs in effect at the time of application for service.

Please let us know if you have questions. Have a great day!

Amanda Duncan, ARWP

Land Agent

Truckee Meadows Water Authority

1355 Capital Blvd. | Reno, NV 89502

O: (775) 834-8035, M: (775) 815-7195

aduncan@tmwa.com | www.tmwa.com



From: Stark, Katherine [mailto:KRStark@washoeconomy.us]
Sent: Friday, December 23, 2016 1:37 PM
To: Duncan, Amanda
Cc: Stark, Katherine; Emerson, Kathy; Zimmerman, John
Subject: December Agency Review Memo IV

Good afternoon,

Please find the attached Agency Review Memo with a case received in December by Washoe County Community Services Department, Planning & Development.

You've been asked to review the application for **Item 1**. The item description and a link to the application are provided in the memo. Also, please see the yellow highlighted note regarding an Agency Review Meeting for this case on January 11, 2017.

Thank you!

Katy Stark

Office Support Specialist

Washoe County Community Services Department

(775) 328-3618 (office)



NEVADA DIVISION OF
**ENVIRONMENTAL
PROTECTION**

STATE OF NEVADA
Department of Conservation & Natural Resources
Brian Sandoval, Governor
Leo M. Drozdoff, P.E., Director
David Emme, Administrator

January 11, 2017

BOB SACK
DISTRICT HEALTH
P.O. BOX 11130
RENO NV 89520

**Re: Tentative Map-Bailey Creek Estates; APN's 017-520-03 & 017-480-02
56 Lots in Washoe County, Nevada**

Dear Mr. SACK:

The Nevada Division of Environmental Protection has reviewed the above referenced subdivision and recommends approval of said subdivision with respect to water pollution and sewage disposal, provided that the Washoe County commits to provide sewage service to said subdivision.

Please note that if the developer of this subdivision will disturb more than one acre, he/she is required to obtain coverage under NDEP's Construction Stormwater General Permit NVR100000. A Notice of Intent must be filed electronically and submitted with a \$200 fee prior to commencing any earth-disturbing activities at the site. Visit NDEP's Bureau of Water Pollution Control's website at: http://ndep.nv.gov/bwpc/storm_cont03.htm for more information about this permit.

Sincerely,

Pat Mohn, P.E.
Technical Services Branch
Bureau of Water Pollution Control

cc:

-Washoe County Department of Water Resources, Utility Division, P.O. 11130 Reno 89520
-Kelly Mullin, Planner; Washoe County Comm. Services; 1001 E. 9th Street Bldg. A, Reno, NV 89512
Engineer: WOOD RODGERS 1361 Corporate Blvd., Reno, NV 89502
Developer: STL COMPANY LLC.; 16500 Wedge Pkwy. Bldg. A, Ste. 200, Reno, NV 89511

Control No. 11057



REGIONAL TRANSPORTATION COMMISSION

Metropolitan Planning • Public Transportation & Operations • Engineering & Construction

Metropolitan Planning Organization of Washoe County, Nevada

January 6, 2017

FR: Chrono/PL 183-17

Ms. Kelly Mullin, Planner
 Community Services Department
 Washoe County
 P.O. Box 11130
 Reno, NV 89520

RE: WTM16-003 (Bailey Creek Estates)

Dear Ms. Mullin,

The RTC has reviewed this request to approve a 56-lot single-family residential subdivision on two parcels totaling approximately 29 acres. Residential lots will range in size from 14,520 sq. ft. to 21,780 sq. ft. with lot sizes averaging 17,869 sq. ft. This project is located immediately south of the intersection of Geiger Grade Road and Shadow Hills Drive

The 2035 Regional Transportation Plan (RTP) identifies Geiger Grade as an arterial with moderate access control (MAC). To maintain regional roadway capacity, the following RTP access management standards should be maintained.

Access Management Standards-Arterials ¹ and Collectors							
Access Management Class	Posted Speeds	Signals Per Mile and Spacing ²	Median Type	Left From Major Street? (Spacing from signal)	Left From Minor Street or Driveway?	Right Decel Lanes at Driveways?	Driveway Spacing ³
Moderate Access Control	40-45 mph	3 or less Minimum spacing 1590 feet	Raised or painted w/turn pockets	Yes 500 ft. minimum	No, on 6 or 8-lane roadways w/o signal	Yes ⁴	200 ft./300 ft.

¹ On-street parking shall not be allowed on any new arterials. Elimination of existing on-street parking shall be considered a priority for major and minor arterials operating at or below the policy level of service.
² Minimum signal spacing is for planning purposes only; additional analysis must be made of proposed new signals in the context of existing conditions, planned signalized intersections, and other relevant factors impacting corridor level of service.
³ Minimum spacing from signalized intersections/spacing other driveways.
⁴ If there are more than 60 inbound right-turn movements during the peak-hour.

The policy Level of Service (LOS) standard for Geiger Grade is LOS D. Policy LOS for intersections shall be designed to provide a level of service consistent with maintaining the policy level of service of the intersecting corridor. This project should be required to meet all the conditions necessary to complete road improvements to maintain policy LOS standards.

The draft 2040 Regional Transportation Plan identifies Geiger Grade to be widened from 2 lanes to 4 lanes from Toll Road to Rim Rock Road in the 2022-2026 timeframe. Dedication of right-of-way or setbacks adequate to complete the 2040 RTP improvements are recommended. See the attached

typical 98' right-of-way section for a 4-lane facility. Additional right-of-way may be required for dedicated turn lanes at intersections.

Please have the developer contact RTC Senior Transit Planner, Tina Wu, at 775-335-1908 or twu@rtcwashoe.com to discuss potential future transit.

The RTP, the RTC Bicycle/Pedestrian Master Plan and the Nevada Department of Transportation Pedestrian Safety Action Plan, all indicate that new development and re-development will be encouraged to construct pedestrian and bicycle facilities, internal and/or adjacent to the development, within the regional road system. Also, these plans recommend that the applicant be required to design and construct any sidewalks along the frontage of the property in conformance with the stated ADA specifications.

Thank you for the opportunity to comment on this application. Please feel free to contact me at 775-332-0174 if you have any questions or comments.

Sincerely,



Rebecca Kapuler
Planner

RK/jm

Attachment

Copies: Bill Whitney, Washoe County Community Services
Jae Pullen, NDOT District II
Daniel Doenges, Regional Transportation Commission
Julie Masterpool, Regional Transportation Commission
Tina Wu, Regional Transportation Commission
David Jickling, Regional Transportation Commission

/471 Bailey Creek Estates

TYPICAL 4-LANE RIGHT-OF-WAY SECTION

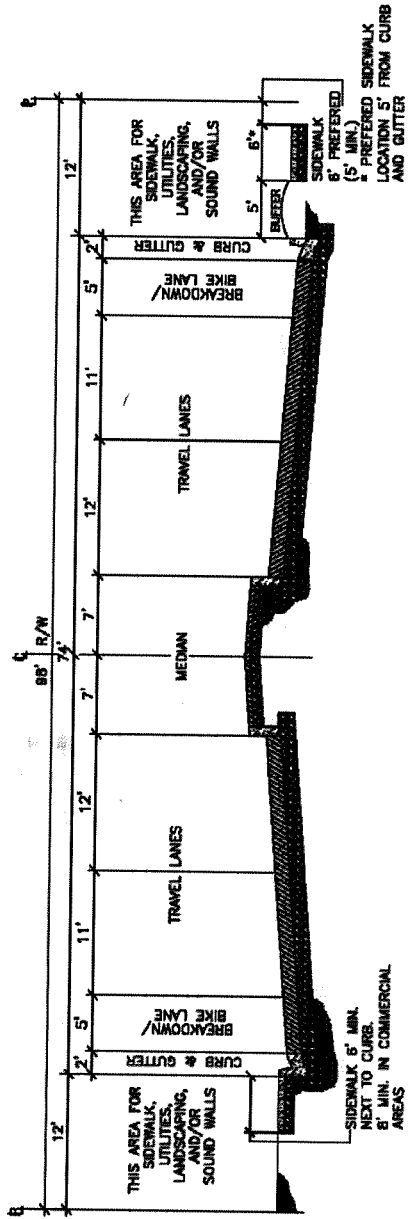

TYPICAL 98' RIGHT-OF-WAY SECTION
FOUR TRAVEL LANES

REGIONAL TRANSPORTATION COMMISSION
RIGHT-OF-WAY SECTION





**DEPARTMENT OF CONSERVATION AND NATURAL RESOURCES
DIVISION OF WATER RESOURCES**

901 South Stewart Street, Suite 2002
Carson City, Nevada 89701-5250
(775) 684-2800 • Fax (775) 684-2811
(800) 992-0900
(In Nevada Only)
www.water.nv.gov

January 3, 2017

Subdivision Review No. 20888-T, Case Number WTM16-003

RE: Comments on Approval of Tentative Map for Bailey Creek Estates

To: Kelly Mullin, Planner
Community Development Department
City of Reno
P. O. Box 1900
Reno, NV 89505

Name: *Bailey Creek Estates*

County: Washoe County – Geiger Grade/Highway 341 and Shadow Hills Drive

Location: A portion of Section 27, Township 18 North, Range 20, East, MDB&M.

Plat: Tentative: Fifty-six (56) lots, common areas, and right-of-ways totaling approximately 28.76 acres and being Washoe County Assessor's Parcel Numbers 017-520-03 and 017-480-02.

**Water Service
Commitment**

Allocation: No water is committed at this time. No estimate of demand.

**Owner-
Developer:** C. B. Maddox
P. O. Box 70577
Reno, NV 89570

Engineer: Blake D. Carter, P. E.
Wood Rodgers
5440 Reno Corporate Drive
Reno, NV 89511

Water Supply: Truckee Meadows Water Authority

General: There are no active water rights appurtenant to the described lands in this proposed project. Any water used on the described lands should be provided by an established utility or under permit issued by the State Engineer's Office.

All waters of the State belong to the public and may be appropriated for beneficial use pursuant to the provisions of Chapters 533 and 534 of the Nevada Revised Statutes (NRS), and not otherwise.

Any water or monitor wells, or boreholes that may be located on either acquired or transferred lands are the ultimate responsibility of the owner of the property at the time of the transfer and must be plugged and abandoned as required in Chapter 534 of the Nevada Administrative Code. If artesian water is encountered in any well or borehole it shall be controlled as required in NRS § 534.060(3).

Municipal water service is subject to Truckee Meadows Water Authority rules and regulations and approval by the Office of the State Engineer regarding water quantity and availability.

A Will Serve from Truckee Meadows Water Authority and mylar map of the proposed project must be presented to the State Engineer for approval and signed through his office prior to development.

Action: Tentative approval of *Bailey Creek Estates* subdivision based on acceptance of Water Will Serve by Truckee Meadows Water Authority.

Best regards,

Steve Shell
Water Resource Specialist II

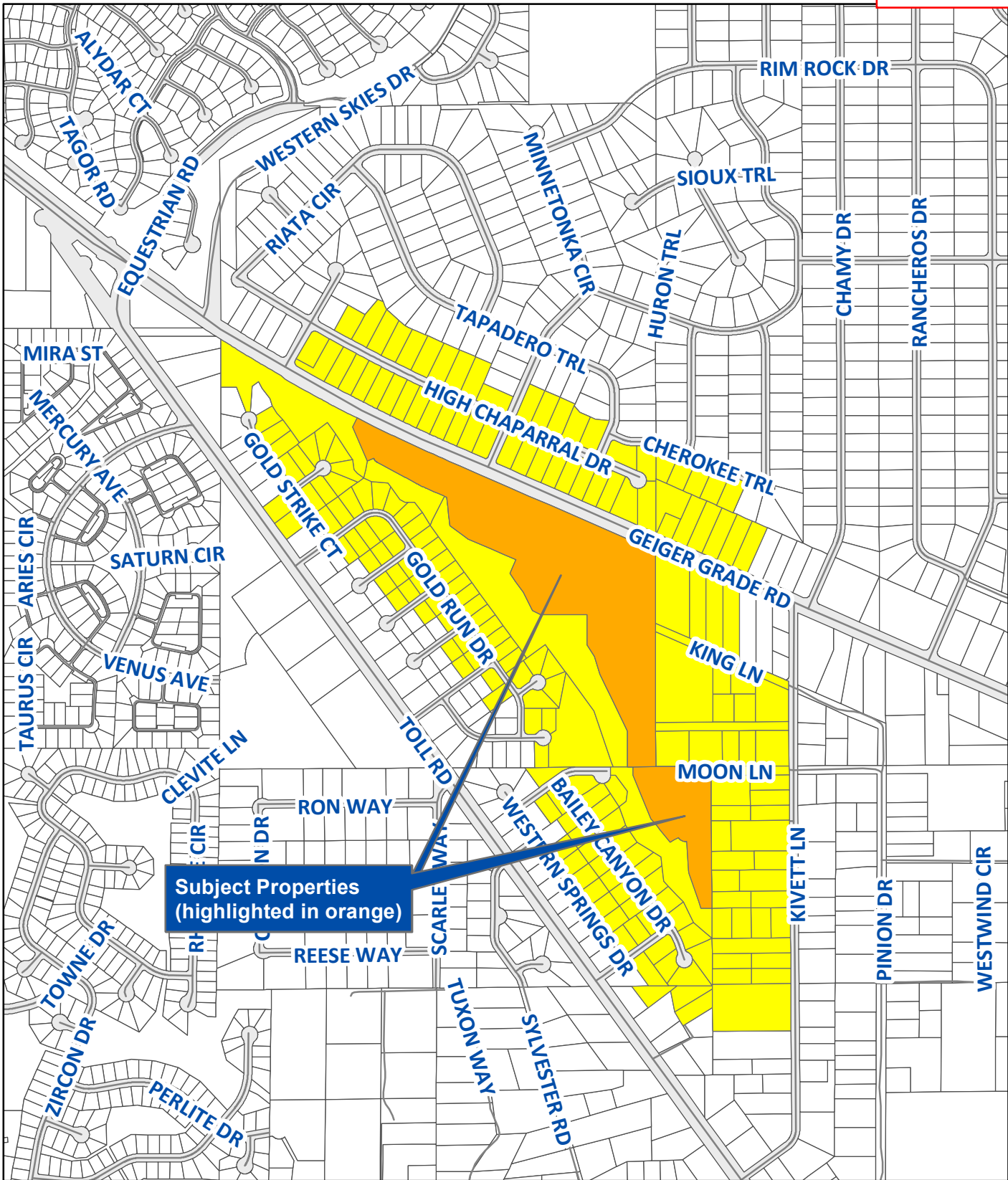

Subject Properties
(highlighted in orange)

Public Notice Map

Tentative Map Case WTM16-003
(Bailey Creek Estates)

204 parcels selected within a distance
of 500 feet of the project site.

Source: Planning and Development Division

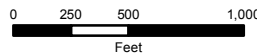
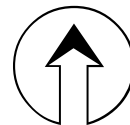

Date: December 21, 2016

Community Services
Department



Post Office Box 11130
Reno, Nevada 89520 (775) 328-3600

From: JEFF HALICZER
To: [Mullin, Kelly](#)
Subject: Baily Creek Estates
Date: Saturday, January 21, 2017 5:35:14 PM

Received a notice about the upcoming meeting and because of other commitments I will not be able to attend. Yet felt the need to express my opinion.

I am a resident in the area off Geiger Grade, on Pinion Dr. Been in the south part of the Truckee Meadows since I moved to Nevada in 1990. I love it out here for a variety of reasons.

Yet the urban sprawl that has encroached further south all the time is upsetting.

I own an acre and all the neighbors in the area are on an acre, it is country and it is wonderful to not have people jammed in so tight.

But to hear about this development and the small lot sizes of .41 of an acre is upsetting. Kutri Ranch is possibly similar and the houses are so close to each other I am amazed at the number of houses in these developments.

The inadequate access into and out of the proposed area is a concern. The lack of a center turn lane on Geiger Grade (I have called the NVDOT a few times on this) and the amount of space for drainage (.75) is inadequate especially with the recent weather we have been having.

I oppose this plan and wanted to go on record on this.

Respectfully,
Jeff Haliczzer
15225 Pinion Dr.
Reno, Nevada 89521

From: Holly O'Driscoll
To: [Mullin, Kelly](#)
Cc: [Kim Davis](#); solferino@sbcglobal.net; joncady@sbcglobal.net; [Bill O'Driscoll](#)
Subject: Re: Bailey Creek Estates Development off Geiger Grade
Date: Thursday, January 19, 2017 8:06:52 PM

Ms. Mullen,

Reviewing the information online about this proposed subdivision raises several concerns regarding development of this plot of land. I live on High Chaparral Drive and part of this development will be across Geiger Grade from me.

Traffic:

The estimated traffic volume seems extremely low for the number of homes. Years ago, under a prior plan for about 100 homes (as I recall) the estimated traffic was 500 or more trips a day (I do not recall the exact numbers). Because of the volume -- my understanding was that a dedicated turn lane on the south side of Geiger Grade would be included in future development. I do not see that in the plot maps for this project. The traffic numbers that are in the plan are confusing. How many trips a day will be added to the intersection?

I was told that under the prior plan, access going *into* the development would be allowed from Geiger Grade, via the one-lane widening. Exit access onto Geiger Grade would be from Kivet or Moon Lane -- areas that do not cause an intersection problem.

The reason for my concern: Shadow Hills is a major artery in and out of the Foothills neighborhood. If people get backed up getting in or out via Shadow Hills, they will use High Chaparral Drive to High Chaparral Way as a cut off -- endangering the many children and pedestrians on my block. This would adversely impact my neighborhood -- and my property values. There is a dedicated turn lane on Geiger Grade to turn north into to High Chaparral. There should be a dedicated lane to turn south into this project.

Flood/water/drainage

I see that part of the proposed area is designated as a flood zone. In these past weeks, significant flooding has occurred over there -- and backed up to the point of closing Toll Road.

This plan seems to indicate that it would not impact or change the flood danger. I am not convinced ... and quite concerned that grading and topography changes could cause water to rise to the Geiger Grade level -- and by extension toward my property.

Horses

Wild horses traverse and graze in that plot on a regular basis. I presume they also access whatever water flows down the drainage area that flows through the entire plot. Will the horses continue to have access? Will more be pushed into the road -- and in front of cars?

I would appreciate your feed back on these concerns -- particularly the traffic issue as that is the most crucial and likely harm to be felt by residents throughout the existing Foothill neighborhood. New development should not take precedence over our safety -- especially when it can be mitigated by changing the traffic pattern in and out of this project.

Best Regards,

Holly O'Driscoll
1240 High Chaparral Drive
Reno, NV 89521
775-762-7576

Tentative Map Application Bailey Creek Estates

Submitted to Washoe County
December 15, 2016

ORIGINAL

Prepared for

Silver Crest Homes

16500 Wedge Parkway, Bldg A, Ste 200

Reno, NV 89511

Prepared by



WOOD RODGERS

BUILDING RELATIONSHIPS ONE PROJECT AT A TIME

1361 Corporate Blvd • Reno, NV 89502 • Tel: 775.823.4068 • www.woodrogers.com

WTM16-003 - EXHIBIT E

Table of Contents

Section 1

- ❖ Washoe County Application Forms
 - Washoe County Development Application
 - Tentative Subdivision Map Application and Supplemental Information
 - Property Owner Affidavit
 - Legal Description
 - Proof of Property Tax Payment
 - Request to Reserve New Street Names
 - Title Report (Original packet only)

Section 2

- ❖ Project Description
 - Location
 - Site Characteristics
 - Zoning and Master Plan Designations
 - Cooperative Planning Area
 - Current Request
 - Tentative Map Design
 - House Design
 - Grading
 - Drainage
 - Traffic and Circulation
 - Common Areas
 - Landscaping
 - Fencing
 - Project Signage
 - Water, Sewer and Utilities
 - Schools
 - Police and Fire Service
 - Parks
 - Phasing
 - Development Statistics Summary

Section 3

- ❖ Maps and Supporting Information
 - Vicinity Map
 - Site Aerial
 - Assessor's Parcel Map
 - Existing Master Plan Map
 - Regulatory Zoning Map with Tentative Map Overlay
 - Slope Map with Tentative Map Overlay
 - Landscape Area Exhibit
 - Reduced Tentative Map Set

Submitted Separately

- ❖ Reports and Studies
 - Geotechnical Summary
 - Preliminary Drainage Report

Map Pocket

- ❖ Tentative Map Set

Section 1

Washoe County Development Application

Your entire application is a public record. If you have a concern about releasing personal information, please contact Planning and Development staff at 775.328.3600.

Project Information		Staff Assigned Case No.: _____	
Project Name: Bailey Creek Estates			
Project Description: A Tentative Map for a 56 lot single family residential subdivision with lots ranging in size from 1/2 acre to 1/3 acre.			
Project Address: Geiger Grade/State Route 431			
Project Area (acres or square feet): 28.76 acres			
Project Location (with point of reference to major cross streets AND area locator): The proposed project is located E. of Toll Road; S. of Geiger Grade in the SETM Area Plan/Toll Rd Character Mgmt Area			
Assessor's Parcel No.(s):	Parcel Acreage:	Assessor's Parcel No.(s):	Parcel Acreage:
017-520-03	23.63		
017-480-02	5.125		
Section(s)/Township/Range: Section 27, T18N, R20E			
Indicate any previous Washoe County approvals associated with this application: Case No.(s).			
Applicant Information (attach additional sheets if necessary)			
Property Owner:		Professional Consultant:	
Name: Charles B. Maddox		Name: Wood Rodgers, Inc.	
Address: P.O. Box 70577, Reno, NV		Address: 1361 Corporate Blvd; Reno, NV	
Zip: 89570		Zip: 89502	
Phone: 852-4466	Fax:	Phone: 775-823-5258	Fax: 823-4066
Email: danmcgill@prodigy.net		Email: shuggins@woodrodgers.com	
Cell:	Other:	Cell: 775-250-8213	Other:
Contact Person: Dan McGill		Contact Person: Stacie Huggins	
Applicant/Developer:		Other Persons to be Contacted:	
Name: Silver Crest Homes		Name: Wood Rodgers, Inc.	
Address: 16500 Wedge Parkway, Bldg A, Ste 200		Address: 1361 Corporate Blvd; Reno, NV	
Zip: 89511		Zip: 89502	
Phone: 916-787-3420	Fax:	Phone: 775-823-4050	Fax: 826-4066
Email: rbalestreri@timlewis.com		Email: sstrickland@woodrodgers.com	
Cell: 916-425-5657	Other:	Cell: 775-745-4207	Other:
Contact Person: Rich Balestreri		Contact Person: Steve Strickland	
For Office Use Only			
Date Received:	Initial:	Planning Area:	
County Commission District:		Master Plan Designation(s):	
CAB(s):		Regulatory Zoning(s):	

Tentative Subdivision Map Application Supplemental Information

(All required information may be separately attached)

Chapter 110 of the Washoe County Code is commonly known as the Development Code. Specific references to tentative subdivision maps may be found in Article 608, Tentative Subdivision Maps.

1. What is the location (address or distance and direction from nearest intersection)?

The proposed project is located on two parcels fronting on Geiger Grade/Highway 341 directly south of Shadow Hills Drive. The subject parcels are approximately 1/4 mile from the intersection of Geiger Grade/Highway 341 and Toll Road in the Toll Road Character Management Area of the Southeast Truckee Meadows Area Plan (SETM).

2. What is the subdivision name (proposed name must not duplicate the name of any existing subdivision)?

Bailey Creek Estates

3. Density and lot design:

a. Acreage of project site	28.76 acres
b. Total number of lots	56
c. Dwelling units per acre	1.95 du/acre
d. Minimum and maximum area of proposed lots	0.33 min - 0.81 max
e. Minimum width of proposed lots	80 feet
f. Average lot size	0.41 acres (17,869 sqft)

4. Utilities:

a. Sewer Service	Washoe County
b. Electrical Service	NV Energy
c. Telephone Service	AT&T
d. LPG or Natural Gas Service	NV Energy
e. Solid Waste Disposal Service	Waste Management
f. Cable Television Service	Charter Communications
g. Water Service	TMWA

5. For common open space subdivisions (Article 408), please answer the following:

a. Acreage of common open space:

0.75+/- acres

b. Development constraints within common open space (slope, wetlands, faults, springs, ridgelines):

Common open space areas are needed to accommodate drainage and on-site detention.

c. Range of lot sizes (include minimum and maximum lot size):

min lot size = 0.33 acre; max lot size = 0.81 acre

d. Average lot size:

0.41 ac

e. Proposed yard setbacks if different from standard:

Setbacks for Bailey Creek Estates will match the zoning setbacks of MDS.

f. Justification for setback reduction or increase, if requested:

Not applicable.

g. Identify all proposed non-residential uses:

There are no non-residential uses associated with Bailey Creek Estates.

- h. Improvements proposed for the common open space:

Common areas are proposed to remain natural. The only anticipated disturbance within these areas is anticipated to be associated with detention and drainage facilities for appropriate, controlled conveyance of stormwater and drainage.

- i. Describe or show on the tentative map any public or private trail systems within common open space of the development:

There are no public or private trail systems within the Bailey Creek Estates project.

- j. Describe the connectivity of the proposed trail system with existing trails or open space adjacent to or near the property:

Not applicable.

- k. If there are ridgelines on the property, how are they protected from development?

There are no ridgelines on the property.

- l. Will fencing be allowed on lot lines or restricted? If so, how?

Yes, fencing will be allowed on side and rear lot lines in accordance with Washoe County standards.

m. Identify the party responsible for maintenance of the common open space:

The Bailey Creek Estates Homeowners Association will be responsible for maintenance of the common open space areas.

6. Is the project adjacent to public lands or impacted by "Presumed Public Roads" as shown on the adopted April 27, 1999 Presumed Public Roads (see Washoe County Engineering website at <http://www.washoecounty.us/pubworks/engineering.htm>). If so, how is access to those features provided?

The site does not appear to be impacted by "presumed public roads" based on the Presumed Public Roads "Carson" area map.

7. Is the parcel within the Truckee Meadows Service Area?

Yes No

8. Is the parcel within the Cooperative Planning Area as defined by the Regional Plan?

Yes No If yes, within what city? City of Reno

9. Will a special use permit be required for utility improvement? If so, what special use permits are required and are they submitted with the application package?

No special use permits are required for this project.

10. Has an archeological survey been reviewed and approved by SHPO on the property? If yes, what were the findings?

At this time, an archaeological survey has not been conducted.

11. Indicate the type and quantity of water rights the application has or proposes to have available:

a. Permit #		acre-feet per year	
b. Certificate #		acre-feet per year	
c. Surface Claim #		acre-feet per year	
d. Other #		acre-feet per year	

e. Title of those rights (as filed with the State Engineer in the Division of Water Resources of the Department of Conservation and Natural Resources):

The property is within the TMWA Retail Water Service Area. Water rights to serve the project will be dedicated prior to recordation of each final map.

12. Describe the aspects of the tentative subdivision that contribute to energy conservation:

The proposed project should be considered as an in-fill project as the site is surrounded by existing development on all sides. To address energy conservation, homes are anticipated to be constructed using energy efficient designs including water conservation considerations.

13. Is the subject property in an area identified Planning and Development as potentially containing rare or endangered plants and/or animals, critical breeding habitat, migration routes or winter range? If so, please list the species and describe what mitigation measures will be taken to prevent adverse impacts to the species:

The site does not appear to be in an area containing rare or endangered plants/animals, critical breeding habitat, migration routes or winter range.

14. If private roads are proposed, will the community be gated? If so, is a public trail system easement provided through the subdivision?

The proposed project does not include any private roads. The primary access will be Sterling Hills Way, which will be accessed by an extension of Shadow Hills Drive on the south side of Geiger Grade. Gated emergency access will be provided at the intersection of Sterling Hills Way and Moon Lane near the southeast portion of the site.

Pedestrian access will be provided through the project site via streets and sidewalks.

15. Is the subject property located adjacent to an existing residential subdivision? If so, describe how the tentative map complies with each additional adopted policy and code requirement of Article 434, Regional Development Standards within Cooperative Planning Areas and all of Washoe County, in particular, grading within 50 and 200 feet of the adjacent developed properties under 5 acres and parcel matching criteria:

The project site is adjacent to the Bailey Creek drainage, which serves as a natural buffer between the proposed project and the previously approved, and fully built, Cottonwood Creek Subdivision. The existing single family residences to the south and east of the project site have a medium density suburban (MDS) land use designation, consistent with the project site. To comply with lot adjacency standards, in addition to the natural buffer provided by the Bailey Creek drainage, parcels abutting the drainage have been sized in accordance with the SETM requirements with similar sized lots adjacent to the drainage and larger lots along the exterior of the project.

16. Are there any applicable policies of the adopted area plan in which the project is located that require compliance? If so, which policies and how does the project comply?

The project site is located in the Southeast Truckee Meadows Area Plan, Toll Road Character Management Area and has a land use designation of Medium Density Suburban. In accordance with SETM Policy 2.13, the proposed project restricts density to 2 dwelling units per acre and includes 1/2 acre lots on the exterior that abuts developed MDS and 1/3 acre lots where abutting higher intensity land uses. This proposed project meets SETM Policy 2.13 (a) and (b) as well as all Washoe County Development Code requirements.

17. Are there any applicable area plan modifiers in the Development Code in which the project is located that require compliance? If so, which modifiers and how does the project comply?

The project site is located in the Southeast Truckee Meadows Area Plan and has a land use designation of Medium Density Suburban. In accordance with Section 110.212.05 Medium Density Suburban Area Modifier, the maximum number of dwelling units that may be located in the MDS zone in the Southeast Truckee Meadows planning area is two units per acre. Additionally, the modifier limits minimum lot area to 1/2 acre lots on an exterior that abuts developed MDS and 1/3 acre lots where abutting higher intensity land uses.

This proposed project meets WC Development Code and SETM Policy 2.13 (a) and (b) requirements.

18. Will the project be completed in one phase or is phasing planned? If so, please provide that phasing plan:

The subdivision is anticipated to be developed in one phase.

19. Is the project subject to Article 424, Hillside Development? If yes, please address all requirements of the Hillside Ordinance in a separate set of attachments and maps.

Yes No If yes, include a separate set of attachments and maps.

20. Is the project subject to Article 418, Significant Hydrologic Resources? If yes, please address Special Review Considerations within Section 110.418.30 in a separate attachment.

Yes No If yes, include separate attachments.

Grading

Please complete the following additional questions if the project anticipates grading that involves: (1) Disturbed area exceeding twenty-five thousand (25,000) square feet not covered by streets, buildings and landscaping; (2) More than one thousand (1,000) cubic yards of earth to be imported and placed as fill in a special flood hazard area; (3) More than five thousand (5,000) cubic yards of earth to be imported and placed as fill; (4) More than one thousand (1,000) cubic yards to be excavated, whether or not the earth will be exported from the property; or (5) If a permanent earthen structure will be established over four and one-half (4.5) feet high:

21. How many cubic yards of material are you proposing to excavate on site?

50,000 +/- cubic yards

22. How many cubic yards of material are you exporting or importing? If exporting of material is anticipated, where will the material be sent? If the disposal site is within unincorporated Washoe County, what measures will be taken for erosion control and revegetation at the site? If none, how are you balancing the work on-site?

It is not anticipated that any import or export of soil (to or from the site) will be necessary. Site grading will result in balance of cut/fill materials.

23. Can the disturbed area be seen from off-site? If yes, from which directions, and which properties or roadways? What measures will be taken to mitigate their impacts?

Yes. The proposed development will be visible from all sides. Landscaping and trees are proposed along Geiger Grade to mitigate views from the north. Fencing will be provided along side and rear yards in accordance with County code to help mitigate visibility of the proposed project.

24. What is the slope (Horizontal:Vertical) of the cut and fill areas proposed to be? What methods will be used to prevent erosion until the revegetation is established?

Grading is proposed to not exceed 3:1. However, if grading exceeds 3:1, it may be armored per code. Where necessary, erosion control matting, or equivalent, may be provided until such revegetation is established.

25. Are you planning any berms and, if so, how tall is the berm at its highest? How will it be stabilized and/or revegetated?

Berms, no greater than 3:1, may be associated with fencing along Geiger Grade. Berms will be revegetated with native vegetation where appropriate.

26. Are retaining walls going to be required? If so, how high will the walls be, will there be multiple walls with intervening terracing, and what is the wall construction (i.e. rockery, concrete, timber, manufactured block)? How will the visual impacts be mitigated?

No. Walls are not proposed as part of this project.

27. Will the grading proposed require removal of any trees? If so, what species, how many, and of what size?

No. The proposed project does not require removal of any trees.

28. What type of revegetation seed mix are you planning to use and how many pounds per acre do you intend to broadcast? Will you use mulch and, if so, what type?

Specific seed mix for revegetation areas will be determined during final design, however, the applicant does not anticipate using mulch.

29. How are you providing temporary irrigation to the disturbed area?

No areas are proposed to need temporary irrigation. Dust control on flatter areas of the graded site will be provided through the use of dust palliative or other acceptable, non-irrigated means.

30. Have you reviewed the revegetation plan with the Washoe Storey Conservation District? If yes, have you incorporated their suggestions?

No.

Property Owner Affidavit

Applicant Name: Silver Crest Homes

The receipt of this application at the time of submittal does not guarantee the application complies with all requirements of the Washoe County Development Code, the Washoe County Master Plan or the applicable area plan, the applicable regulatory zoning, or that the application is deemed complete and will be processed.

STATE OF NEVADA)
)
COUNTY OF WASHOE)

I, C. B. Maddox
(please print name)

being duly sworn, depose and say that I am the owner* of the property or properties involved in this application as listed below and that the foregoing statements and answers herein contained and the information herewith submitted are in all respects complete, true, and correct to the best of my knowledge and belief. I understand that no assurance or guarantee can be given by members of Planning and Development.

(A separate Affidavit must be provided by each property owner named in the title report.)

Assessor Parcel Number(s): 017-520-03 and 017-480-02

Printed Name C. B. Maddox

Signed [Signature]

Address P.O. Box 70577

Reno, NV 89570

Subscribed and sworn to before me this
24 day of December, 2014
[Signature]
Notary Public in and for said county and state

My commission expires: 10/25/19

(Notary Stamp)



*Owner refers to the following: (Please mark appropriate box.)

- Owner
- Corporate Officer/Partner (Provide copy of record document indicating authority to sign.)
- Power of Attorney (Provide copy of Power of Attorney.)
- Owner Agent (Provide notarized letter from property owner giving legal authority to agent.)
- Property Agent (Provide copy of record document indicating authority to sign.)
- Letter from Government Agency with Stewardship

LEGAL DESCRIPTION

All that real property situate in the County of Washoe, State of Nevada, described as follows:

PARCEL 1:

Parcel 3B-1 of Reversion to Acreage Tract Map of COTTONWOOD ESTATES UNITS 7 & 8, according to the map thereof, filed in the office of the County Recorder of Washoe County, State of Nevada, on June 24, 2014, as Document No. 4366040, Official Records, Tract Map No. 5083.

PARCEL 2:

Parcels A and C as shown on that certain Second Parcel Map for JANE P. PRECISSI, Parcel Map No. 1948, according to the map thereof, filed in the office of the County Recorder of Washoe County, State of Nevada, on February 13, 1986, as File No. 1052547, Official Records.

EXCEPTING THEREFROM that portion within the boundaries of COMSTOCK ESTATES UNIT 1, filed in the office of the County Recorder of Washoe County, Nevada, on August 26, 1992, as File No. 1600029, Map No. 2875 and amended by document recorded October 26, 1992, as Document No. 1616563, Official Records.

ALSO EXCEPTING THEREFROM that portion lying within the boundaries of COMSTOCK ESTATES UNIT NO. 2, according to the map thereof, filed in the office of the County Recorder of Washoe County, State of Nevada, on March 18, 1994, as File No. 1776765, Official Records.

FURTHER EXCEPTING THEREFROM that portion lying within the boundaries of COMSTOCK ESTATES UNIT NO. 3, according to the map thereof, filed in the office of the County Recorder of Washoe County, State of Nevada, on September 8, 1994, as File No. 1831350, Official Records

Assessor's Parcel Number(s): 017-480-02 & 017-520-03

Prepared by:
Wood Rodgers, Inc.
1361 Corporate Boulevard
Reno, Nevada 89502

Daniel A. Bigrigg, PLS
Nevada Certification No. 19716

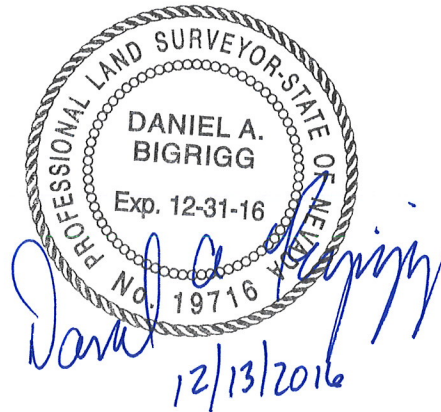

Account Detail

[Back to Search Results](#)

[Change of Address](#)

[Print this Page](#)

Washoe County Parcel Information

Parcel ID	Status	Last Update
01752003	Active	12/13/2016 2:09:51 AM

Current Owner:
 MADDOX, CHARLES B
 PO BOX 70577
 RENO, NV 89570

SITUS:
 0 GEIGER GRADE RD
 RENO NV

Taxing District:
 4000

Geo CD:

Legal Description
 Township 18 Section 27 Lot 3B-1 Block Range 20 SubdivisionName _REVERSION

Tax Bill (Click on desired tax year for due dates and further details)

Tax Year	Net Tax	Total Paid	Penalty/Fees	Interest	Balance Due
2016	\$3,873.67	\$1,936.84	\$0.00	\$0.00	\$1,936.83
2015	\$3,866.39	\$3,866.39	\$0.00	\$0.00	\$0.00
2014	\$3,746.48	\$3,746.48	\$0.00	\$0.00	\$0.00
Total					\$1,936.83

Important Payment Information

- ALERTS:** If your real property taxes are delinquent, the search results displayed may not reflect the correct amount owing. Please contact our office for the current amount due.
- For your convenience, online payment is available on this site. E-check payments are accepted without a fee. However, a service fee does apply for online credit card payments. See Payment Information for details.

Pay Online

Payments will be applied to the oldest charge first.

Select a payment option:

- Total Due \$1,936.83
- Oldest Due \$968.42
- Partial

[ADD TO CART](#)

\$0.00

Pay By Check

Please make checks payable to:
 WASHOE COUNTY TREASURER

Mailing Address:
 P.O. Box 30039
 Reno, NV 89520-3039

Overnight Address:
 1001 E. Ninth St., Ste D140
 Reno, NV 89512-2845

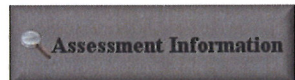
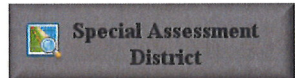

The Washoe County Treasurer's Office makes every effort to produce and publish the most current and accurate information possible. No warranties, expressed or implied, are provided for the data herein, its use, or its interpretation. If you have any questions, please contact us at (775) 328-2510 or tax@washoecounty.us

This site is best viewed using Google Chrome, Internet Explorer 11, Mozilla Firefox or Safari.

Account Detail

[Back to Search Results](#)

[Change of Address](#)

[Print this Page](#)

Washoe County Parcel Information		
Parcel ID	Status	Last Update
01748002	Active	12/13/2016 2:09:51 AM
Current Owner: MADDOX, CHARLES B PO BOX 70577 RENO, NV 89570		SITUS: 0 MOON LN WASHOE COUNTY NV
Taxing District 4000	Geo CD:	
Legal Description		
Township 18 Range 20 SubdivisionName _UNSPECIFIED Section 34 Lot FR PAR C & FR PAR A Block		

Tax Bill (Click on desired tax year for due dates and further details)					
Tax Year	Net Tax	Total Paid	Penalty/Fees	Interest	Balance Due
2016	\$428.02	\$214.02	\$0.00	\$0.00	\$214.00
2015	\$426.92	\$426.92	\$0.00	\$0.00	\$0.00
2014	\$413.60	\$413.60	\$0.00	\$0.00	\$0.00
Total					\$214.00

Important Payment Information
<ul style="list-style-type: none"> ALERTS: If your real property taxes are delinquent, the search results displayed may not reflect the correct amount owing. Please contact our office for the current amount due. For your convenience, online payment is available on this site. E-check payments are accepted without a fee. However, a service fee does apply for online credit card payments. See Payment Information for details.

Pay Online	
Payments will be applied to the oldest charge first.	
Select a payment option:	
<input checked="" type="radio"/> Total Due	\$214.00
<input type="radio"/> Oldest Due	\$107.00
<input type="radio"/> Partial	<input type="text"/>
ADD TO CART	

\$0.00

Pay By Check

Please make checks payable to:
WASHOE COUNTY TREASURER

Mailing Address:
P.O. Box 30039
Reno, NV 89520-3039

Overnight Address:
1001 E. Ninth St., Ste D140
Reno, NV 89512-2845

- Payment Information
- Special Assessment District
- Installment Date Information
- Assessment Information

The Washoe County Treasurer's Office makes every effort to produce and publish the most current and accurate information possible. No warranties, expressed or implied, are provided for the data herein, its use, or its interpretation. If you have any questions, please contact us at (775) 328-2510 or tax@washoecounty.us

This site is best viewed using Google Chrome, Internet Explorer 11, Mozilla Firefox or Safari.

Request to Reserve New Street Name(s)

The Applicant is responsible for all sign costs.

Applicant Information

Name: Silver Crest Homes
Address: 16500 Wedge Parkway, Building A, Suite 200
Reno, Nevada 89511

Phone : (916) 425-5657 Fax: _____
 Private Citizen Agency/Organization

Street Name Requests

(No more than 14 letters or 15 if there is an "i" in the name. Attach extra sheet if necessary.)

<u>Sterling Hills Way</u>	
<u>Sterling Hills Court</u>	
<u>Granite Mine Court</u>	

If final recordation has not occurred within one (1) year, it is necessary to submit a written request for extension to the coordinator prior to the expiration date of the original approval request.

Location

Project Name: Bailey Creek Estates
 Reno Sparks Washoe County
Parcel Numbers: 017-520-03 and 017-480-02
 Subdivision Parcelization Private Street

Please attach maps, petitions and supplementary information.

Approved: _____ Date: _____
Regional Street Naming Coordinator
 Except where noted

Denied: _____ Date: _____
Regional Street Naming Coordinator

Washoe County Department of Public Works

Post Office Box 11130 - 1001 E. Ninth Street
Reno, NV 89520-0027

Phone: (775) 328-3667 - Fax: (775) 328-6133 Email: streetnames@washoecounty.us

Section 2

Project Description

Location

The Bailey Creek Estates project is in south Washoe County near the intersection of Toll Road and Geiger Grade/Highway 341. The site consists of 28.76± acres and includes Washoe County Assessor Parcel Numbers: 017-520-03 and 017-480-02. The property is bordered by Geiger Grade/Highway 341 and existing residential to the north, a mix of undeveloped land and scattered single family residences to the east, and the Bailey Creek drainage and single family homes in the Cottonwood Creek subdivision to the south and west. *Refer to Vicinity Map, Assessor's Parcel Map and Site Aerial in Section 3 of this submittal packet.*

Site Characteristics

The project site is relatively flat with approximately 97.3 percent of the site with slopes less than 15%. *(Refer to Slope Map in Section 3 of this submittal packet).* The Bailey Creek drainage runs between Toll Road and Geiger Grade in an open space corridor located south of the site. The site is characterized by native vegetation (primarily native shrubs, sagebrush, grasses, and pinion pines).

A drainageway extends along the southern edge of the site in a south/north direction. The drainageway generally follows the FEMA flood zone AE alignment.

Zoning and Master Plan Designations

The project site is within the Toll Road Character Management Area of the Southeast Truckee Meadows Area Plan (SETM). Master Plan designations are as follows: Rural (0.90± acres) and Suburban Residential (27.815± acres). Zoning designations include: General Rural (0.90± acres) and Medium Density Suburban (27.815± acres) *(Refer to Existing Zoning Map, Existing Master Plan Map Exhibits in Section 3 of this submittal packet).*

Density calculations for the total number of lots permitted (excluding any allotment for the General Rural designated acreage) are as follows:

- Medium Density Suburban - 2.0 acre minimum (27.815± acres/2.0 = 55.63 lots)
- General Rural – 40 acre minimum (0.90± acres/40 = 0.023 lots)

Total Lots Permitted = 55.63 (rounded to 56)

Cooperative Planning Area

The project site is in a Cooperative Planning Area and is subject to standards outlined in Washoe County Development Code Article 434. There are existing single family residences to the south and east of the project site that have a medium density suburban (MDS) land use designation. To comply with lot adjacency standards, in addition to the natural buffer provided by the Bailey Creek drainage, parcels abutting the drainage have been sized consistent with adjacent parcel sizes.

Current Request

The current project is a 56-lot single family residential development. Lots range in size from about 1/3 acre (14,520 sqft) to 1/2 acre (21,780 sqft) with an average lot size of 0.41± acres (17,869± sqft). The overall density is 1.95 units per acre and is in accordance with the allowed maximum density of 2.0 units per acre as outlined in the SETM. The project includes approximately 0.75± acres of common area.

The request is summarized as follows:

- A **Tentative Subdivision Map** to permit development of a 56-lot single-family subdivision on 28.76± acres.

Tentative Map Design

The Bailey Creek Estates project is an appropriate use for the project site and should be considered as an infill project. The proposed project is surrounded by existing residential development. Furthermore, the project has been designed in accordance with the policies outlined in the SETM Toll Road Character Management Area Plan and other pertinent Washoe County Development Code regulations.

Density calculations for the total number of lots permitted (excluding any allotment for the General Rural designated acreage) are as follows:

- Medium Density Suburban -2.0 acre minimum ($27.815\pm \text{ acres}/2.0 = 55.63 \text{ lots}$)
- General Rural – 40 acre minimum ($0.90\pm \text{ acres}/40 = 0.023 \text{ lots}$)

Total Lots Permitted = 55.63 (rounded to 56)

While the majority of the site will be developed with single family lots, the project will include approximately 0.75± acres of common area or 2.6% of the site. The overall density is 1.95 dwelling units per acre. (*Refer to Tentative Map Plan Set in Section 3 and Map Pocket of this submittal packet*).

Minimum lot sizes, widths and setbacks for the final map are proposed as follows:

Minimum Lot Size: 14,520± square feet

Minimum Lot Width: 80 feet

Minimum Building Envelope: 3,600 square feet

Minimum Setbacks:

Front Yard Setback = 20 feet

Side Yard Setback = 8 feet

Rear Yard Setback = 20 feet

House Design

Homes are proposed to be one and two story designs with minimum two car garages. House models are not available at this time.

Grading

Disturbed areas will be landscaped and/or revegetated with native vegetation and stabilized in accordance with Washoe County requirements. (*Refer to Tentative Map Plan Set in Section 3 and Map Pocket of this submittal packet*).

Drainage

The proposed drainage system for the project site consists of sheet flow from the lots and streets into gutters with which storm water is conveyed into drop inlets and underground storm drain pipes. Onsite flows will be directed to detention basins or directly to Bailey Creek. Offsite flows from the MDS parcels to the east will be picked up in v-ditches located on the project's east boundary. The ditches will pick up the sheet flow from the east and convey it to the underground storm drain system. Ultimately, all of the runoff collected from the offsite areas and developed portions of the project site will be directed into

proposed detention basins. There will be no negative impacts to adjacent or downstream properties as a result of the proposed development during the 5-year and 100-year storms due to the implementation of the proposed storm water management system. *(Refer to Tentative Map Plan Set and Preliminary Drainage Report in Section 3 and Map Pocket of this submittal packet).*

Traffic and Circulation

Access to the subdivision will be from an extension of Shadow Hills Drive with gated emergency access at the intersection of Sterling Hills Way and Moon Lane. The portion of Moon Lane that is located on the project site will be improved with a 50-foot right-of-way section in accordance with Washoe County design requirements for rural areas. At the project boundary, Moon Lane has an access easement that will allow connectivity with Kivett Lane. In addition to roadway improvements, the proposed subdivision includes sidewalk located on the south side of the main street through the project. *(Refer to Tentative Map Plan Set in Section 3 and Map Pocket of this submittal packet).*

Common Areas

Common areas are strategically located within the subdivision to accommodate detention and/or drainage improvements. *(Refer to Tentative Map Plan Set in Section 3 and Map Pocket of this submittal packet).* Common areas total 0.75± acres and will be landscaped and/or re-vegetated with native vegetation. *(Refer to Preliminary Landscaping Plan in Section 3 and the Map Pocket of this submittal packet).* Maintenance of common areas associated with the project will be maintained by the Bailey Creek Estates Home Owners Association (HOA).

Landscaping

In accordance with Section 110.412.35 all front, rear or side yards that adjoin a public street include at least one tree for every fifty linear feet of street frontage. Where lots abut Geiger Grade, the project includes a 5-foot wide buffer strip with four trees per lot. As depicted on the Preliminary Landscape Plan, the project includes 52 trees along Geiger Grade plus 1 additional tree for each lot that abuts public streets the roadways.

Front yard landscaping will also be provided for each lot. *(Refer to Preliminary Landscaping Plan in Section 3 and the Map Pocket of this submittal packet).*

Fencing

With construction of the homes, standard, 6-foot high, solid fencing will be provided along rear and side lot lines throughout the development.

Project Signage

Project signage will consist of monument style entry sign(s) located near the main project entry point along Geiger Grade. Materials will be consistent with the style of the future homes. Lighting of the sign(s) will be indirect.

Water, Sewer and Utilities

Utilities are currently stubbed near the site in Geiger Grade, Shadow Hills Drive and Kivett Lane.

The site is located with the TMWA Retail Water Service Area. Water rights sufficient to serve the proposed subdivision will be dedicated at the time of the final map as required *(Refer to Estimation of Water Demand for Land Development Projects in Section 4 of this submittal packet).*

Sewer service will be provided by Washoe County with treatment at the South Truckee Meadows Wastewater Treatment Facility (STMWRF).

NV Energy will provide gas and electrical service to the project. Telephone service will be provided by AT&T while cable service will be from Charter Communications.

Schools

Students residing in the subdivision will attend Brown Elementary School; Depoali Middle School and Damonte Ranch High School.

Police and Fire Service

Police and fire service will be provided by Truckee Meadows Fire Department. The closest Truckee Meadows Fire Station is Station 14 located at 12300 Old Virginia Road, approximately 3 miles from the intersection of Shadow Hills Drive and Geiger Grade.

Parks

The proposed project is less than 1 mile from Virginia Foothills Park, which is maintained by Washoe County. The park offers 15 acres of recreational opportunities including tennis courts, covered group picnic areas, children's playground areas, exercise cluster, a fitness trail, and a baseball/soccer field.

Phasing

The subdivision is anticipated to be developed in one phase.

Development Statistics Summary

The following is a summary of the development statistics of the site:

Total Site Area:	28.76± acres
Total Dwelling Units:	56 single family residences
Gross Density:	1.95± d.u./acre
Total Lot Area:	23.17± acres
Total Right of Way Area:	4.84± acres
Total Common Area/Open Space	0.75± acres (2.6%±)

Section 3

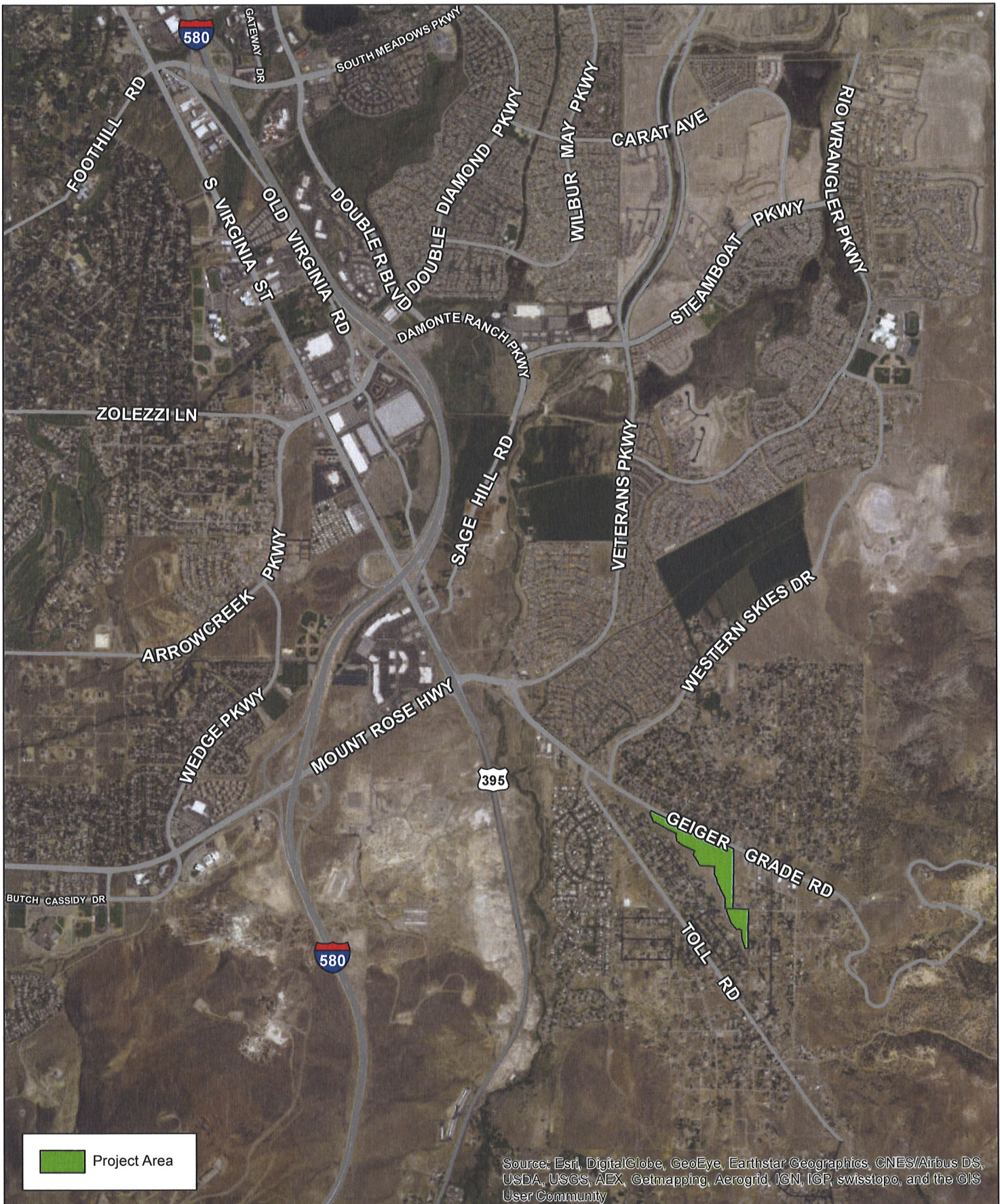

MILES

Vicinity Map

Bailey Creek Estates
Washoe County
December, 2016

WOOD RODGERS
BUILDING RELATIONSHIPS ONE PROJECT AT A TIME
1361 Corporate Boulevard
Reno, NV 89502
Tel: 775.823.4068
Fax: 775.823.4066



Site Aerial
 Bailey Creek Estates
 Washoe County
 December, 2016



WOOD RODGERS
 BUILDING RELATIONSHIPS ONE PROJECT AT A TIME
 1361 Corporate Boulevard
 Reno, NV 89502
 Tel: 775.823.4068
 Fax: 775.823.4068

Assessor's Map Number
017-52

STATE OF NEVADA
WASHOE COUNTY
ASSESSOR'S OFFICE
Joshua G. Wilson, Assessor
1001 East Ninth Street
Building D
Reno, NV 89512
(775) 382-2231



Feet
0 75 150 225 300
1 inch = 300 feet

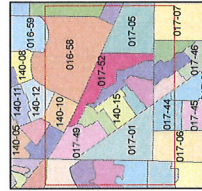
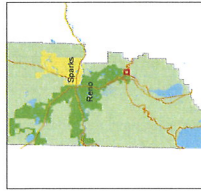

created by: CFB 10/24/2012
last updated: KSE 7/10/14
area previously shown on map(s)

NOTE: This map was prepared for the use of the Washoe County Assessor for assessment and tax purposes. It is not intended to be a survey of the premises. No liability is assumed as to the sufficiency or accuracy of the data delineated hereon.

A POR. OF THE SW 1/4 OF SEC. 27
T18N - R20E

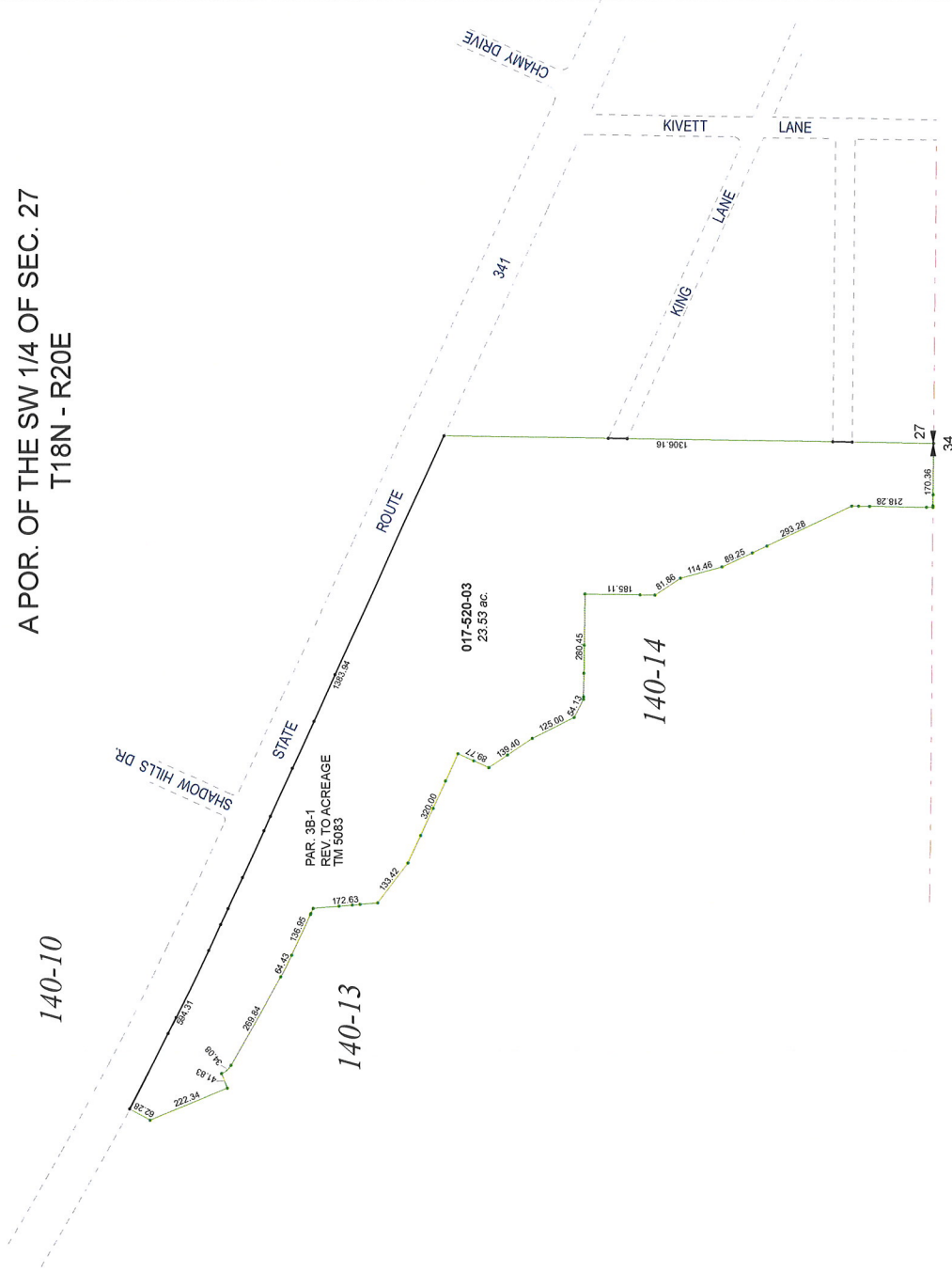

017-48

Assessor's Map Number
017-48

STATE OF NEVADA
WASHOE COUNTY
ASSESSOR'S OFFICE
Joshua G. Wilson, Assessor
1001 East Ninth Street
Reno, NV 89502-2212
(775) 328-2231

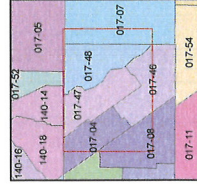
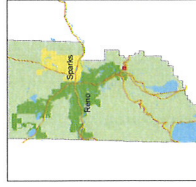
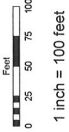

created by: **TWT 5/14/2014**

last updated:

area previously shown on map(s)



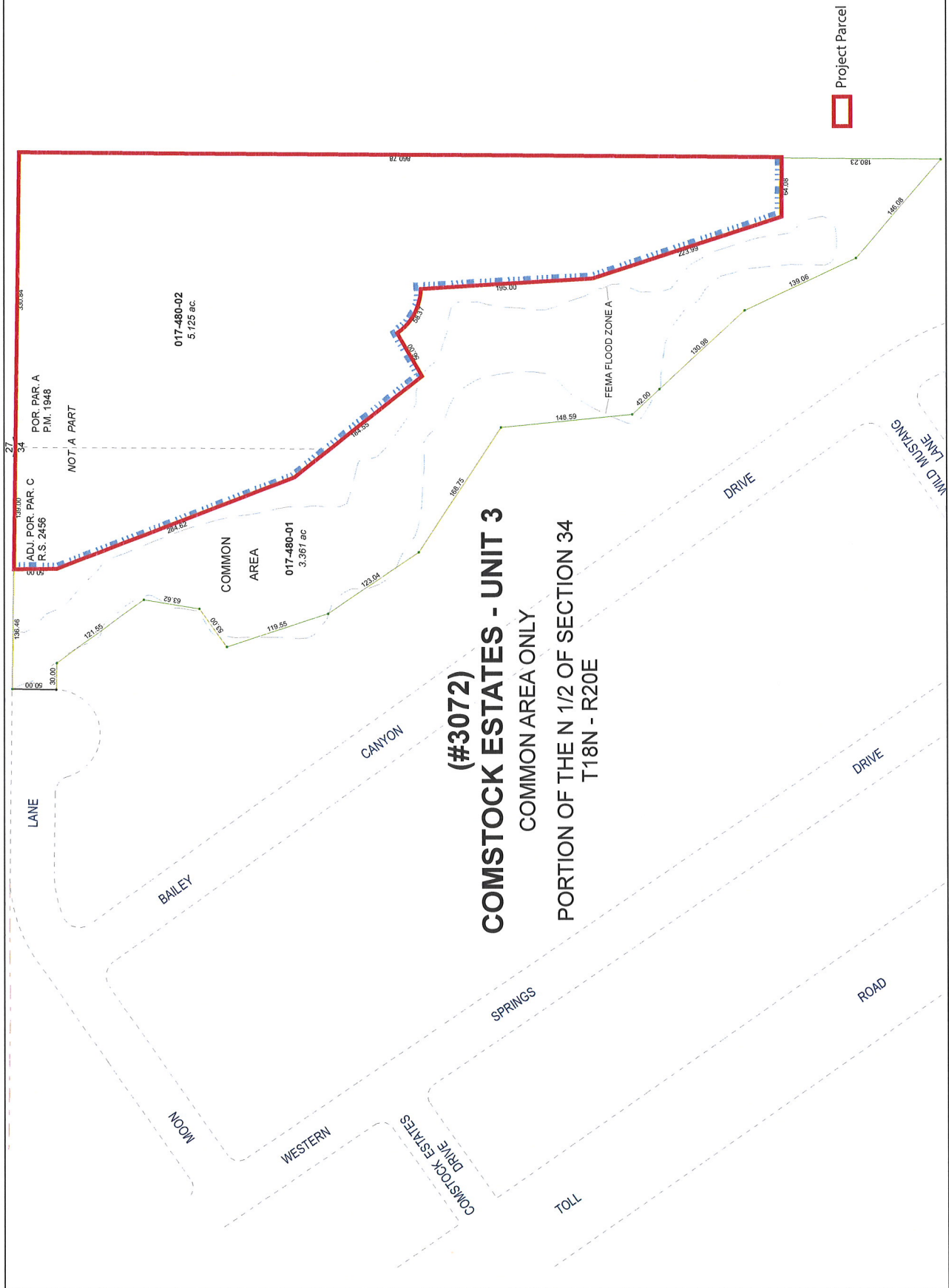

NOTE: This map was prepared for the use of the Washoe County Assessor for assessment and is not intended for any other purpose. No liability is assumed as to the sufficiency or accuracy of the data delineated hereon.

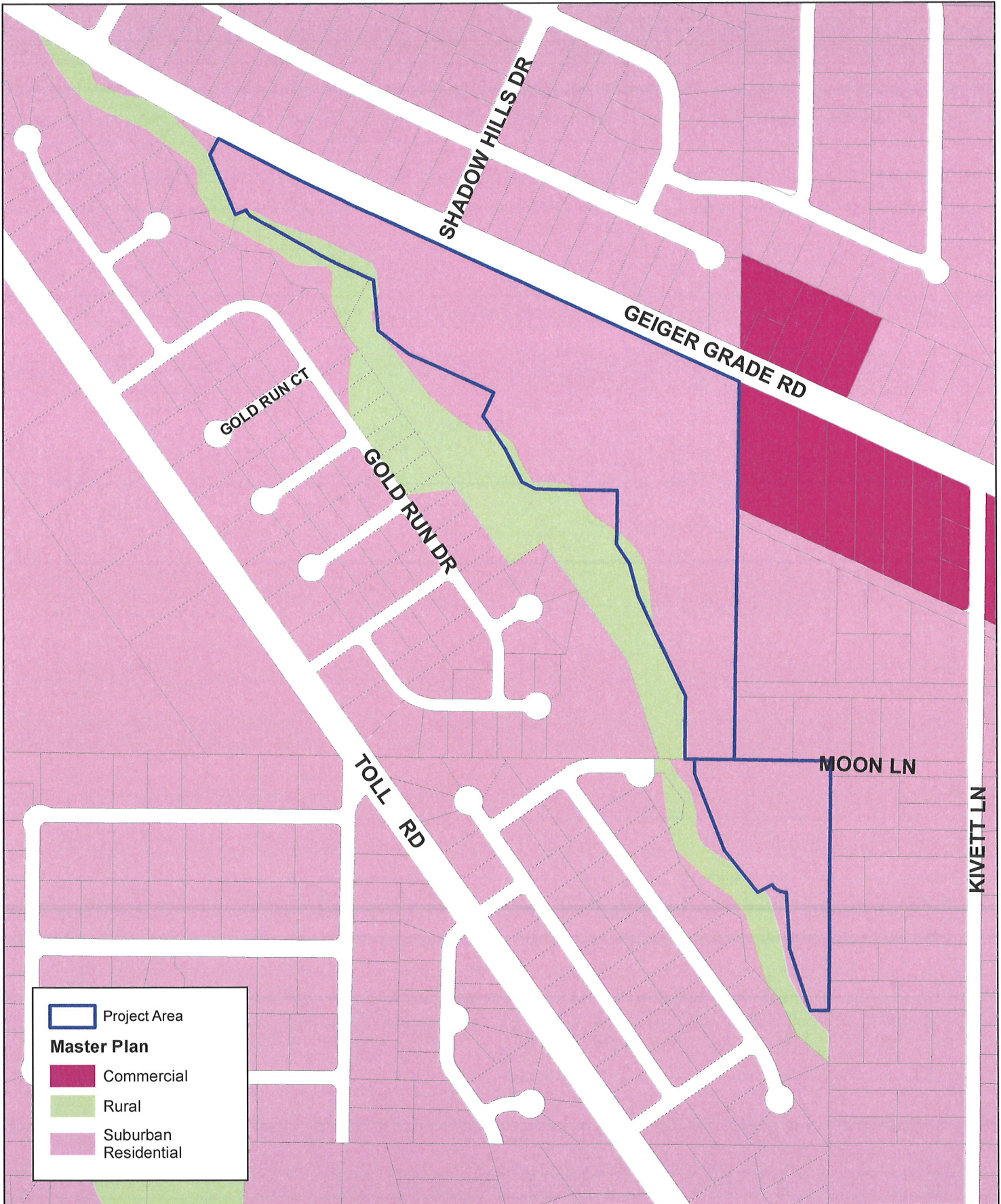

 Project Parcel

(#3072)
COMSTOCK ESTATES - UNIT 3
COMMON AREA ONLY
PORTION OF THE N 1/2 OF SECTION 34
T18N - R20E



	Project Area
Master Plan	
	Commercial
	Rural
	Suburban Residential

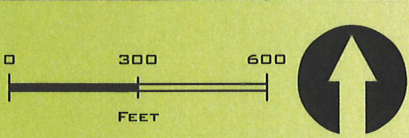

Existing Master Plan
 Bailey Creek Estates
 Washoe County
 December, 2016



WOOD RODGERS
 BUILDING RELATIONSHIPS ONE PROJECT AT A TIME
 1361 Corporate Boulevard
 Reno, NV 89502
 Tel: 775.823.4068
 Fax: 775.823.4068

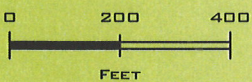
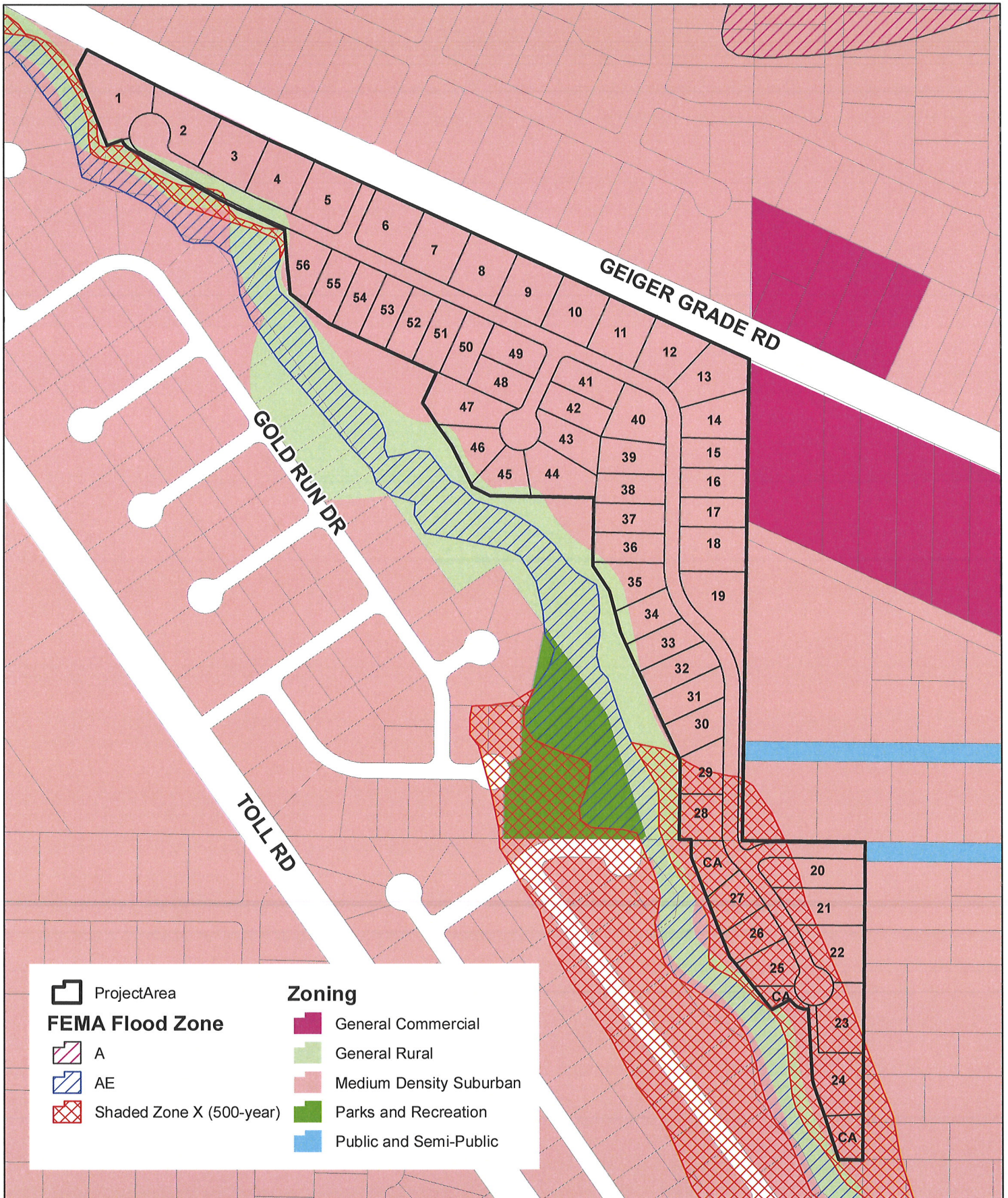

Existing Washoe County Zoning
Bailey Creek Estates
 Washoe County, NV
 December, 2016

WOOD RODGERS
 BUILDING RELATIONSHIPS ONE PROJECT AT A TIME
 1361 Corporate Boulevard Reno, NV 89602
 Tel: 775.823.4068 Fax: 775.823.4066

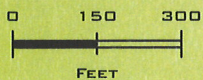
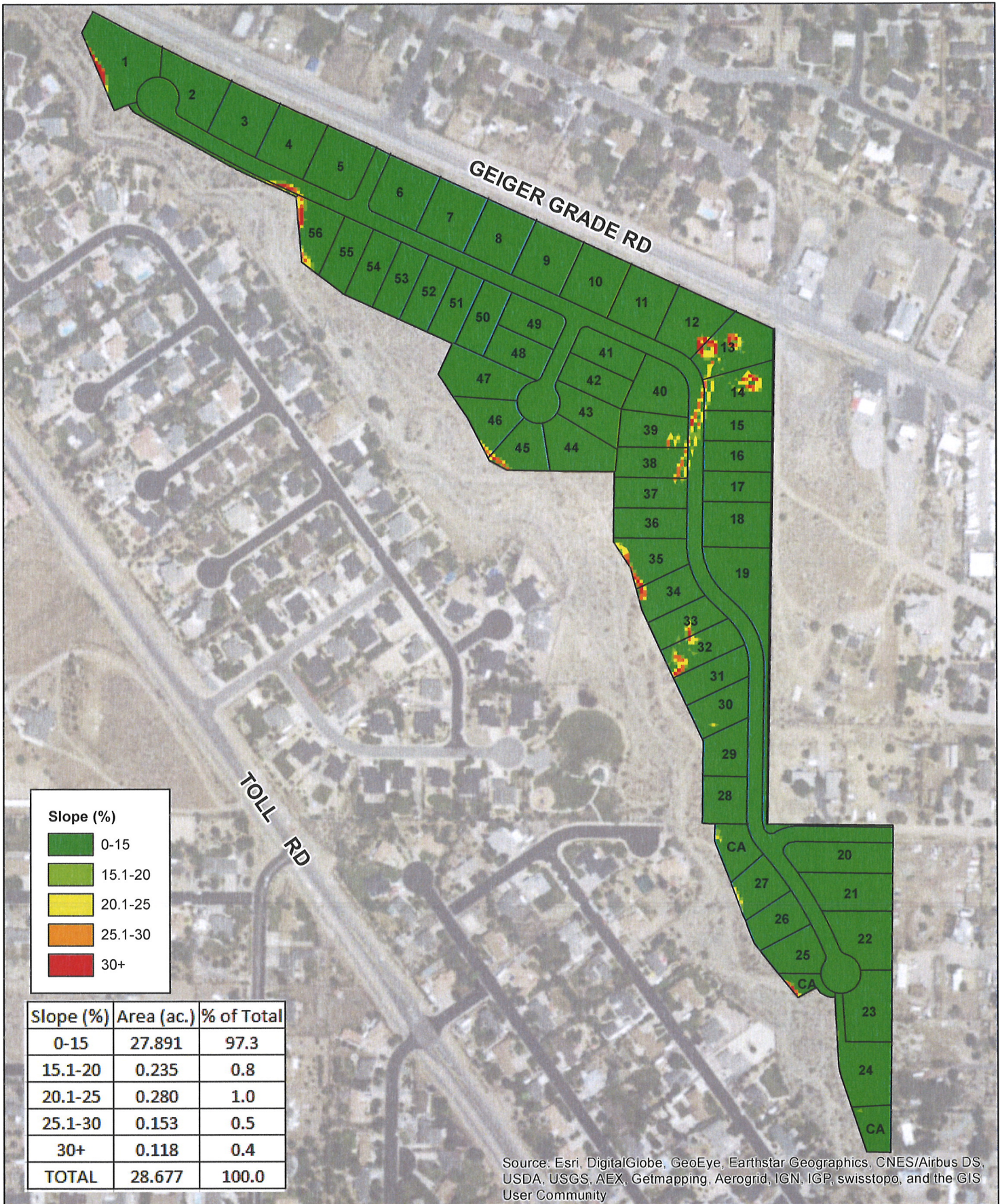

Slope Map
 Bailey Creek Estates
 Washoe County, NV
 December, 2016



WOOD RODGERS
 BUILDING RELATIONSHIPS ONE PROJECT AT A TIME
 1361 Corporate Boulevard
 Reno, NV 89502
 Tel: 775.823.4068
 Fax: 775.823.4066

SOLAEGUI
ENGINEERS

December 22, 2016

Ms. Kelly Mullin
Washoe County Community Services Department
1001 East Ninth Street
Reno, Nevada 89512

Re: Cottonwood Creek Estates, Trip Generation Letter

Dear Kelly:

This letter contains the findings of our trip generation review of the proposed single family subdivision located on Gieger Grade Road in the Virginia City Foothills region of unincorporated Washoe County, Nevada. The project site plan is attached. Fifty six lots are proposed in the subdivision.

Trip generation calculations for the proposed use are based on the Ninth Edition of *ITE Trip Generation* (2012). The calculation sheet is attached for ITE land use #210: Single Family Detached Housing. Table 1 shows the trip generation summary for the proposed future use.

TABLE 1
TRIP GENERATION

<u>LAND USE</u>	<u>ADT</u>	<u>AM PEAK HOUR TOTAL</u>	<u>PM PEAK HOUR TOTAL</u>
Single Family Housing 56 Dwelling Units	533	42	56

As indicated in Table 1, the average daily trip total for the fifty six lots is 533 trips with 42 AM peak hour trips and 56 PM peak hour trips. These totals are below the 80 peak hour trip threshold that triggers the need for a full traffic study. Consequently a traffic study is not required. However, the project developer has offered to prepare a traffic study as a courtesy to the county.

We trust that this information will be adequate for your immediate project review. Please contact us if you have any questions or comments.

Very truly yours,
SOLAEGUI ENGINEERS, LTD

Paul W. Solaegui, P.E.

12-22-16
EXP 6-30-18

Enclosures

Letters/Cottonwood Creek Estates Trip Letter

Solaegui Engineers Ltd. • 715 H Street • Sparks, Nevada 89431 • 775/358-1004 • FAX 775/358-1098

Civil & Traffic Engineers
e-mail: psolaegui@aol.com

WTM16-003 - EXHIBIT E

Average Rate Trip Calculations
 For 56 Dwelling Units of Single Family Detached Housing(210) - [R]

Project:
 Phase:

Open Date:
 Analysis Date:

Description:

	Average Rate	Standard Deviation	Adjustment Factor	Driveway Volume
Avg. Weekday 2-Way Volume	9.52	3.70	1.00	533
7-9 AM Peak Hour Enter	0.19	0.00	1.00	11
7-9 AM Peak Hour Exit	0.56	0.00	1.00	31
7-9 AM Peak Hour Total	0.75	0.90	1.00	42
4-6 PM Peak Hour Enter	0.63	0.00	1.00	35
4-6 PM Peak Hour Exit	0.37	0.00	1.00	21
4-6 PM Peak Hour Total	1.00	1.05	1.00	56
Saturday 2-Way Volume	9.91	3.72	1.00	555
Saturday Peak Hour Enter	0.50	0.00	1.00	28
Saturday Peak Hour Exit	0.43	0.00	1.00	24
Saturday Peak Hour Total	0.93	0.99	1.00	52

Note: A zero indicates no data available.
 Source: Institute of Transportation Engineers
 Trip Generation Manual, 9th Edition, 2012

TRIP GENERATION 2013, TRAFFICWARE, LLC



December 20, 2016

Mr. Charles Maddox
P.O. Box 70577
Reno, NV 89570

**RE: Bailey Creek Estates
Acknowledgement of Water Service
TMWA Work Order 16-5301**

Dear Mr. Maddox:

I have reviewed the plans for the above referenced development (“Project”) as submitted to the Truckee Meadows Water Authority and have determined the Project is within the Truckee Meadows Water Authority’s retail water service area. This letter constitutes an Acknowledgment of Water Service pursuant to NAC 445A.6666, and the Truckee Meadows Water Authority hereby acknowledges that Truckee Meadows Water Authority is agreeable to supplying water service to the Project, subject to applicant satisfying certain conditions precedent, including, without limitation, the dedication of water resources, approval of the water supply plan by the local health authority, the execution of a Water Service Agreement, payment of fees, and the construction and dedication of infrastructure in accordance with our rules and tariffs. This Acknowledgement does not constitute a legal obligation by Truckee Meadows Water Authority to supply water service to the Project, and is made subject to all applicable Truckee Meadows Water Authority Rules.

Review of conceptual site plans or tentative maps by Truckee Meadows Water Authority does not constitute an application for service, nor implies a commitment by Truckee Meadows Water Authority for planning, design or construction of the water facilities necessary for service. The extent of required off-site and on-site water infrastructure improvements will be determined by Truckee Meadows Water Authority upon receiving a specific development proposal or complete application for service and upon review and approval of a water facilities plan by the local health authority. Because the NAC 445A Water System regulations are subject to interpretation, Truckee Meadows Water Authority cannot guarantee that a subsequent water facility plan will be approved by the health authority or that a timely review and approval of the Project will be made. The Applicant should carefully consider the financial risk associated with committing resources to their project prior to receiving all required approvals. After submittal of a complete Application for Service, the required facilities, the cost of these facilities, which could be significant, and associated fees will be estimated and will be included as part of the Water Service Agreement necessary for the Project. All fees must be paid to Truckee Meadows Water Authority prior to water being delivered to the Project.

Please call me at 834-8292 at your convenience if you have any questions.

Sincerely,
Truckee Meadows Water Authority



Keith Ristinen, P.E.
Principal Engineer

BAILEY CREEK ESTATES TENTATIVE MAP TITLE SHEET

OWNER:
CHARLES B. MADDOX, PO.
BOX 70577, RENO, NV 89570

APPLICANT:
STL COMPANY, L.L.C.
16500 WEDGE PARKWAY,
BLDG A, STE 200, RENO, NV

BASIS OF BEARINGS
THE BEARINGS SHOWN ON THIS MAP WERE OBTAINED FROM THE NATIONAL ACCURACY REFERENCE NETWORK (NAD 83) - NORTH AMERICAN DATUM OF 1983 (NAD 83). OBSERVATIONS WERE TRANSMITTED BY THE STATION WOODLIFE - 522501277 AND 744110027. DIMENSIONS SHOWN ARE GROUND DISTANCES. COMBINED GROUND TO GROUND FACTOR = 1.00111709.

BASIS OF ELEVATION
THE ELEVATIONS SHOWN ON THIS MAP WERE OBTAINED FROM THE NATIONAL ACCURACY REFERENCE NETWORK (NAD 83) - NORTH AMERICAN DATUM OF 1983 (NAD 83). OBSERVATIONS WERE TRANSMITTED BY THE STATION WOODLIFE - 522501277 AND 744110027. DIMENSIONS SHOWN ARE GROUND DISTANCES. COMBINED GROUND TO GROUND FACTOR = 1.00111709.

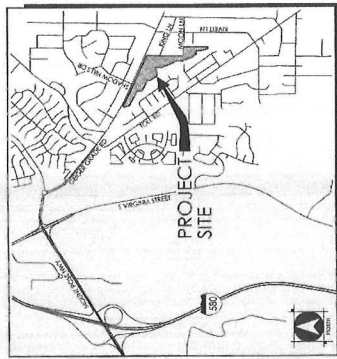

VICINITY MAP
NOT TO SCALE



SITE PLAN
NOT TO SCALE

SITE INFORMATION:

LOT SUMMARY:
SITE AREA: 29.74 AC
TOTAL LOT AREA: 108.38 AC
AVAILABLE LOT AREA: 6.81 AC
COMMON AREA:
COMMON AREA 1 - 7.05 AC
COMMON AREA 2 - 1.05 AC
COMMON AREA 3 - 1.05 AC
COMMON AREA 4 - 1.24 AC
COMMON AREA 5 - 1.24 AC
TOTAL COMMON AREA: 10.64 AC
ASSESSOR'S PARCEL NUMBER:
017-520-03, 017-452-02

ENGINEER'S STATEMENT:

I, STEVEN P. STRICKLAND, DO HEREBY CERTIFY THAT THIS PLAN HAS BEEN PREPARED BY ME OR UNDER MY SUPERVISION AND WAS COMPLETED ON THE DATE OF PREPARATION.



STEVEN P. STRICKLAND, P.E. #15157

SHEET INDEX

SHEET NO.	DWG ID	DRAWING DESCRIPTION
1	T-1	TITLE SHEET
2	B-1	PRELIMINARY BASE FLOOD PLAN
3	C-1	PRELIMINARY GRADING PLAN
4	D-1	PRELIMINARY UTILITIES PLAN
5	L-1	PRELIMINARY LANDSCAPE PLAN

BAILEY CREEK ESTATES
TITLE SHEET



WOOD RODGERS
BUILDING RELATIONSHIPS ONE PROJECT AT A TIME
1381 Corporate Blvd
Reno, NV 89502
Tel 775.823.4068
Fax 775.823.4066

1324006
DECEMBER, 2016

SHEET T-1 OF 5

BAILEY CREEK ESTATES TENTATIVE MAP PRELIMINARY LOT AND BLOCK PLAN

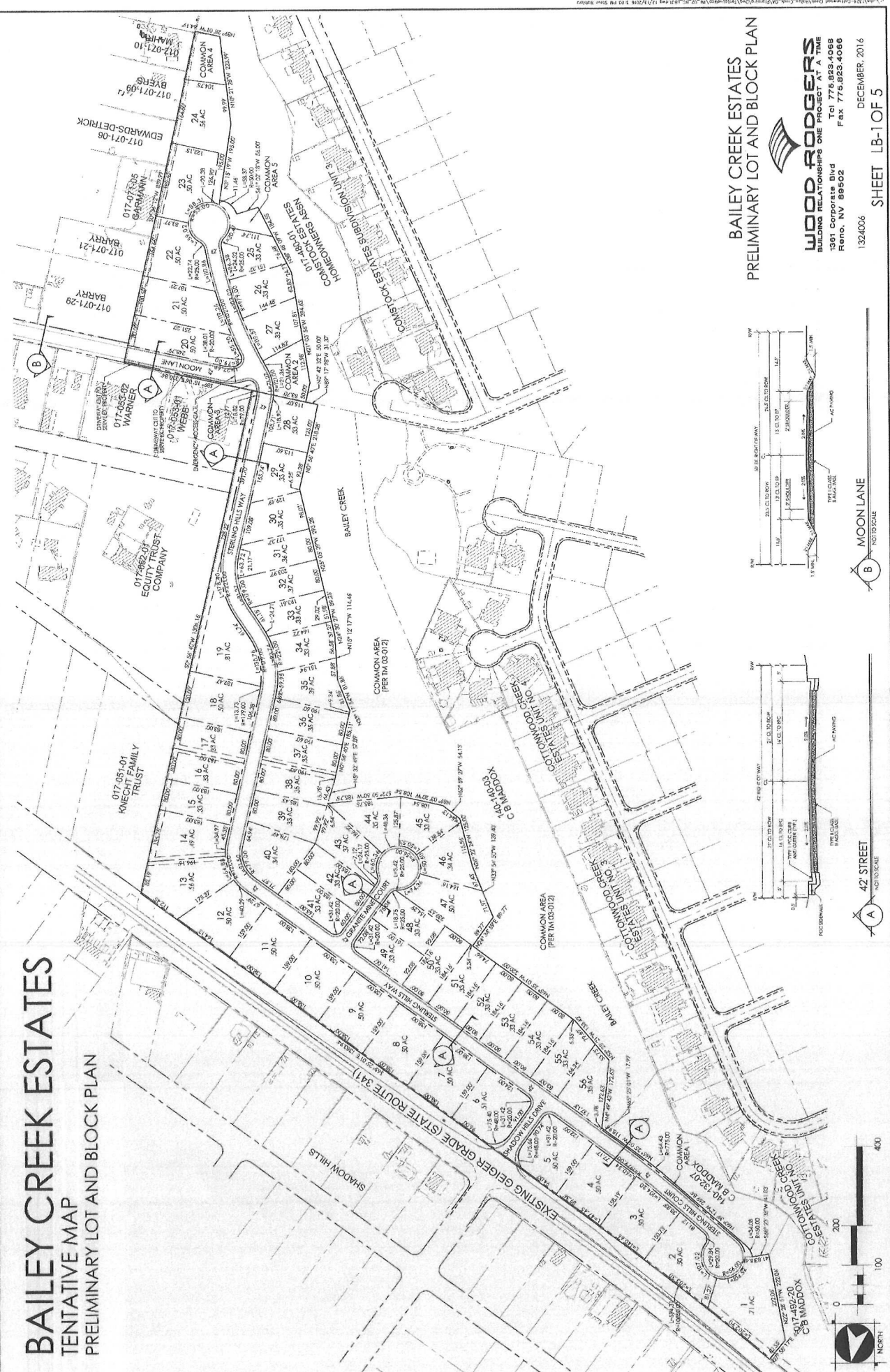

BAILEY CREEK ESTATES
PRELIMINARY LOT AND BLOCK PLAN



WOOD RODGERS
BUILDING RELATIONSHIPS ONE PROJECT AT A TIME
1901 Corporate Blvd
Reno, NV 89502
Tel 775.825.4068
Fax 775.825.4068

1324006 SHEET LB-1 OF 5
DECEMBER, 2016

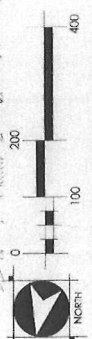
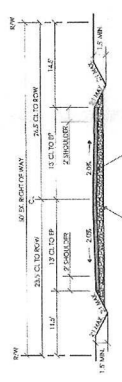

BAILEY CREEK ESTATES

TENTATIVE MAP

PRELIMINARY GRADING PLAN



GRADING STATISTICS

ESTIMATED CUT	50,000 cu.yd.
ESTIMATED FILL	50,000 cu.yd.
AREA OF DISTURBANCE	2.3 AC

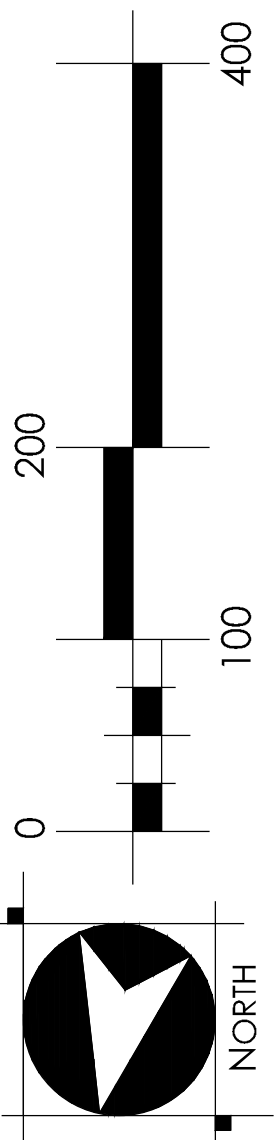

BAILEY CREEK ESTATES
PRELIMINARY GRADING PLAN

WOOD RODGERS
 BUILDING RELATIONSHIPS ONE PROJECT AT A TIME
 1361 Corporate Blvd
 Reno, NV 89502
 Tel 775.823.4068
 Fax 775.823.4066

1324006
 DECEMBER, 2016
SHEET G-1 OF 5

BAILEY CREEK ESTATES TENTATIVE MAP PRELIMINARY UTILITY PLAN



BAILEY CREEK ESTATES
PRELIMINARY UTILITY PLAN



WOOD RODGERS
BUILDING RELATIONSHIPS ONE PROJECT AT A TIME
1961 Corporate Blvd
Reno, NV 89502
Tel 775.825.4068
Fax 775.825.4066
1324006

DECEMBER, 2016
SHEET U-1 OF 5

DETAIL B

DETAIL A

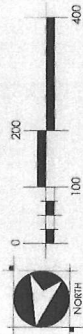

Map Pocket



December 14, 2016
Project No. 1324006

Silver Crest Homes
Mr. Rich Balestreri
3500 Douglas Blvd, Suite 270
Roseville, CA 95661

**RE: Bailey Creek Subdivision
Geotechnical Review**

REF: Updated Geotechnical Investigation – Cottonwood Creek; (Comstock Estates, Units 4-11, dated January 30, 1995); Reno, Nevada; Summit Engineering Corp.; September 6, 2005; Job No. 21545.

Geotechnical Investigation; Comstock Estates, Units 4-11, Washoe County, Nevada; Summit Engineering Corp.; January 30, 1995; File No. 21545.

2012 International Residential Code & Northern Nevada Amendments (IRC)
2012 International Building Code & Northern Nevada Amendments (IBC)

Dear Mr. Balestreri;

Wood Rodgers is pleased to present this review of prior geotechnical work performed for the referenced development and develop preliminary assessments for the development of the project. The purposes of this review are to:

1. Review prior geotechnical design conditions in consideration of contemporary building code requirements and design standards.
2. As appropriate, present recommendations for additional services or refinement of available data.

Our assessments will initially be based upon the opinions and recommendations presented in the referenced geotechnical reports. Additional assessment will then be provided based on readily available geologic and soil maps.

Prior Work

Four test pits have been excavated on the undeveloped portion of the site as part of the original investigation circa 1995. The predominant soil type shown on the logs indicated a dense layer of well-graded gravel with some cobbles and small boulders up to 12 to 18 inches to the maximum depth explored (10 feet). Early geologic mapping shows the majority of the site as a gravel pit. Laboratory testing was performed on the same classification of soils sampled from the currently developed area and indicates a coarse gravel material with a very low fines content. However, within test pit TP-13, to the far east of the

site, a 2 foot cap of clayey sand was indicated that meets the IBC's requisite definition of potentially expansive soils. Groundwater was not encountered during the field exploration.

Three short, inactive quaternary faults were mapped as trending through the southern half of the current development. The subject portion of the site is not crossed by any mapped faults. Although prior reports did not recommend siting occupied structures across any faults, the update report includes an explanation for occupied structures being built over and adjacent to inactive faults in the greater Reno area for decades without significant harm to residents. Seismic design considerations presented are framed around the now obsolete 2003 IBC maps. Liquefaction potential is described as very minimal.

No soluble sulfate data was available from the prior work. Supplemental sampling and testing of soils was required during mass grading to minimize adverse impacts to concrete improvements.

Contemporary Maps and Codes

USGS Quaternary Fault Structures

The United States' Geological Survey interactive fault hazard program indicates three faults trending toward the subject property from across the southern perimeter. These fault structures have been dated as Quaternary (i.e. < 1.6 million years) and have been assigned to the Unnamed Fault Zone East of Reno; however, no associated Holocene aged structures have been mapped or identified. These faults are indicated in Figure 1; mapping also indicates the structures are concealed or inferred through Quaternary deposits.

Natural Resource Conservation Services (NRCS) – Soil Survey Maps

The bulk of the soil profile has been mapped as silty sand with gravel and silty gravel. However, surface soils within the northeast quadrant of the site are indicated to present a sandy clay layer up to 3 feet thick of moderate plasticity which would be characterized as potentially expansive soils.



FIGURE 1 – Geologic Map of Project Area
(Nevada Bureau of Mines and Geology, Mt. Rose – NE
Bonham & Rogers, 1993)

Grading

The surface clay rich soils should be removed from the building pad areas where present within two feet of footing grade established for the pad. This will assure that at least two feet of structural fill is present between the bottom of footing any remaining clay zone. These surface clay soils may be placed in deep fills or in non-structural areas. Structural areas are defined as those areas that support structures or

Mr. Rich Balestreri
Silver Crest Homes
December 14, 2016
Page 3 of 3

planned improvements, including surcharge and active zones associated with retaining structures. Additional grading recommendations would be developed during performance of a design level geotechnical report.

Public Improvements

Most public improvements will be founded in soils presenting an R-Value greatly exceeding 30; we therefore anticipate that Washoe County's minimum structural pavement sections will be satisfactory. If lower R-Values are determined during performance of a design level geotechnical report, the base course thickness should be modified as required by the Public Works Design Manual.

Summary

Overall our preliminary studies indicate the site is well suited for the proposed development. A design level geotechnical report should be prepared for the project that can address specific design and construction considerations based on the current development plan and in consideration of contemporary codes and design standards.

Sincerely,

WOOD RODGERS, INCORPORATED

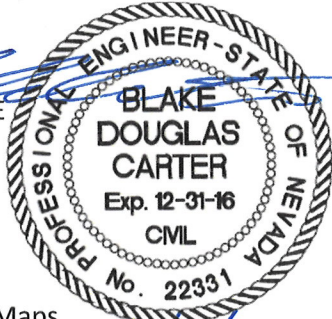

Blake D. Carter, PE
Associate
RE No. 22331
Expires 12/31/16



NRCS Soil Survey Maps
NRCS Engineering Properties

James G. Smith, PE
Principal

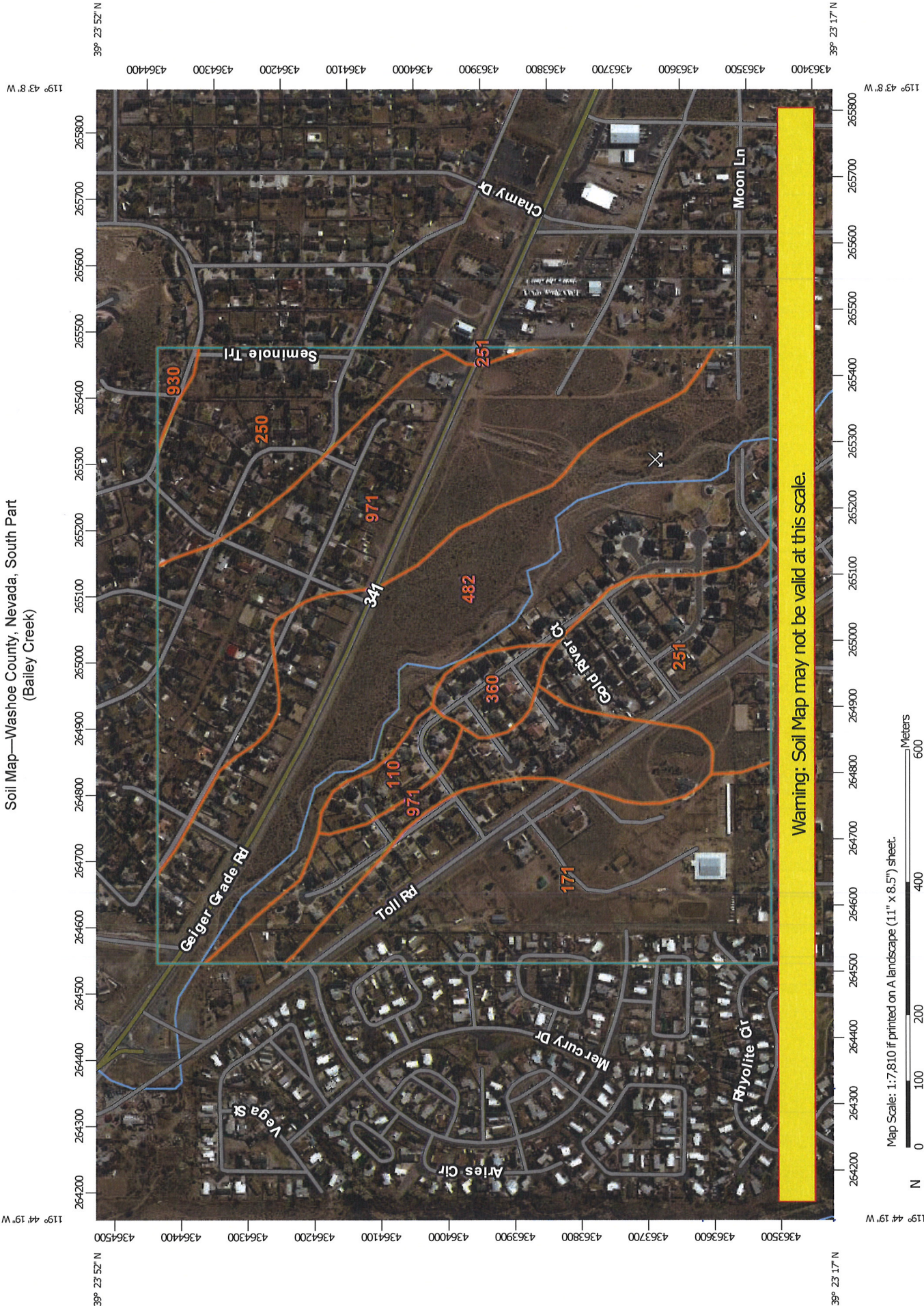
Soil Map—Washoe County, Nevada, South Part
(Bailey Creek)



Warning: Soil Map may not be valid at this scale.

Map Scale: 1:7,810 if printed on A landscape (11" x 8.5") sheet.

Map projection: Web Mercator Corner coordinates: WGS84 Edge tics: UTM Zone 11N WGS84

MAP LEGEND

- Area of Interest (AOI)
 - Area of Interest (AOI)
- Soils
 - Soil Map Unit Polygons
 - Soil Map Unit Lines
 - Soil Map Unit Points
- Special Point Features
 - Blowout
 - Borrow Pit
 - Clay Spot
 - Closed Depression
 - Gravel Pit
 - Gravelly Spot
 - Landfill
 - Lava Flow
 - Marsh or swamp
 - Mine or Quarry
 - Miscellaneous Water
 - Perennial Water
 - Rock Outcrop
 - Saline Spot
 - Sandy Spot
 - Severely Eroded Spot
 - Sinkhole
 - Slide or Slip
 - Sodic Spot
- Water Features
 - Streams and Canals
- Transportation
 - Rails
 - Interstate Highways
 - US Routes
 - Major Roads
 - Local Roads
- Background
 - Aerial Photography
- Spoil Area
- Stony Spot
- Very Stony Spot
- Wet Spot
- Other
- Special Line Features

MAP INFORMATION

The soil surveys that comprise your AOI were mapped at 1:24,000.

Warning: Soil Map may not be valid at this scale.

Enlargement of maps beyond the scale of mapping can cause misunderstanding of the detail of mapping and accuracy of soil line placement. The maps do not show the small areas of contrasting soils that could have been shown at a more detailed scale.

Please rely on the bar scale on each map sheet for map measurements.

Source of Map: Natural Resources Conservation Service
 Web Soil Survey URL: <http://websoilsurvey.nrcs.usda.gov>
 Coordinate System: Web Mercator (EPSG:3857)

Maps from the Web Soil Survey are based on the Web Mercator projection, which preserves direction and shape but distorts distance and area. A projection that preserves area, such as the Albers equal-area conic projection, should be used if more accurate calculations of distance or area are required.

This product is generated from the USDA-NRCS certified data as of the version date(s) listed below.

Soil Survey Area: Washoe County, Nevada, South Part
 Survey Area Data: Version 12, Sep 12, 2016

Soil map units are labeled (as space allows) for map scales 1:50,000 or larger.

Date(s) aerial images were photographed: Apr 2, 2012—Apr 29, 2012

The orthophoto or other base map on which the soil lines were compiled and digitized probably differs from the background imagery displayed on these maps. As a result, some minor shifting of map unit boundaries may be evident.

Map Unit Legend

Washoe County, Nevada, South Part (NV628)			
Map Unit Symbol	Map Unit Name	Acres in AOI	Percent of AOI
110	Jowec variant sandy loam, 4 to 8 percent slopes	4.1	1.9%
171	Indian Creek gravelly sandy loam, 0 to 4 percent slopes	40.2	18.9%
250	Cassiro gravelly sandy loam, 2 to 4 percent slopes	18.5	8.7%
251	Cassiro gravelly sandy loam, 4 to 8 percent slopes	19.2	9.0%
360	Pits	4.1	1.9%
482	Holbrook cobbly loamy sand, 2 to 8 percent slopes	60.5	28.5%
930	Old Camp stony sandy loam, 15 to 30 percent slopes	1.3	0.6%
971	Aladshi sandy loam, 2 to 4 percent slopes	64.7	30.5%
Totals for Area of Interest		212.5	100.0%

Engineering Properties

This table gives the engineering classifications and the range of engineering properties for the layers of each soil in the survey area.

Hydrologic soil group is a group of soils having similar runoff potential under similar storm and cover conditions. The criteria for determining Hydrologic soil group is found in the National Engineering Handbook, Chapter 7 issued May 2007(<http://directives.sc.egov.usda.gov/OpenNonWebContent.aspx?content=17757.wba>). Listing HSGs by soil map unit component and not by soil series is a new concept for the engineers. Past engineering references contained lists of HSGs by soil series. Soil series are continually being defined and redefined, and the list of soil series names changes so frequently as to make the task of maintaining a single national list virtually impossible. Therefore, the criteria is now used to calculate the HSG using the component soil properties and no such national series lists will be maintained. All such references are obsolete and their use should be discontinued. Soil properties that influence runoff potential are those that influence the minimum rate of infiltration for a bare soil after prolonged wetting and when not frozen. These properties are depth to a seasonal high water table, saturated hydraulic conductivity after prolonged wetting, and depth to a layer with a very slow water transmission rate. Changes in soil properties caused by land management or climate changes also cause the hydrologic soil group to change. The influence of ground cover is treated independently. There are four hydrologic soil groups, A, B, C, and D, and three dual groups, A/D, B/D, and C/D. In the dual groups, the first letter is for drained areas and the second letter is for undrained areas.

The four hydrologic soil groups are described in the following paragraphs:

Group A. Soils having a high infiltration rate (low runoff potential) when thoroughly wet. These consist mainly of deep, well drained to excessively drained sands or gravelly sands. These soils have a high rate of water transmission.

Group B. Soils having a moderate infiltration rate when thoroughly wet. These consist chiefly of moderately deep or deep, moderately well drained or well drained soils that have moderately fine texture to moderately coarse texture. These soils have a moderate rate of water transmission.

Group C. Soils having a slow infiltration rate when thoroughly wet. These consist chiefly of soils having a layer that impedes the downward movement of water or soils of moderately fine texture or fine texture. These soils have a slow rate of water transmission.

Group D. Soils having a very slow infiltration rate (high runoff potential) when thoroughly wet. These consist chiefly of clays that have a high shrink-swell potential, soils that have a high water table, soils that have a claypan or clay layer at or near the surface, and soils that are shallow over nearly impervious material. These soils have a very slow rate of water transmission.

Depth to the upper and lower boundaries of each layer is indicated.

Texture is given in the standard terms used by the U.S. Department of Agriculture. These terms are defined according to percentages of sand, silt, and clay in the fraction of the soil that is less than 2 millimeters in diameter. "Loam," for example, is soil that is 7 to 27 percent clay, 28 to 50 percent silt, and less than 52 percent sand. If the content of particles coarser than sand is 15 percent or more, an appropriate modifier is added, for example, "gravelly."

Classification of the soils is determined according to the Unified soil classification system (ASTM, 2005) and the system adopted by the American Association of State Highway and Transportation Officials (AASHTO, 2004).

The Unified system classifies soils according to properties that affect their use as construction material. Soils are classified according to particle-size distribution of the fraction less than 3 inches in diameter and according to plasticity index, liquid limit, and organic matter content. Sandy and gravelly soils are identified as GW, GP, GM, GC, SW, SP, SM, and SC; silty and clayey soils as ML, CL, OL, MH, CH, and OH; and highly organic soils as PT. Soils exhibiting engineering properties of two groups can have a dual classification, for example, CL-ML.

The AASHTO system classifies soils according to those properties that affect roadway construction and maintenance. In this system, the fraction of a mineral soil that is less than 3 inches in diameter is classified in one of seven groups from A-1 through A-7 on the basis of particle-size distribution, liquid limit, and plasticity index. Soils in group A-1 are coarse grained and low in content of fines (silt and clay). At the other extreme, soils in group A-7 are fine grained. Highly organic soils are classified in group A-8 on the basis of visual inspection.

If laboratory data are available, the A-1, A-2, and A-7 groups are further classified as A-1-a, A-1-b, A-2-4, A-2-5, A-2-6, A-2-7, A-7-5, or A-7-6. As an additional refinement, the suitability of a soil as subgrade material can be indicated by a group index number. Group index numbers range from 0 for the best subgrade material to 20 or higher for the poorest.

Percentage of rock fragments larger than 10 inches in diameter and 3 to 10 inches in diameter are indicated as a percentage of the total soil on a dry-weight basis. The percentages are estimates determined mainly by converting volume percentage in the field to weight percentage. Three values are provided to identify the expected Low (L), Representative Value (R), and High (H).

Percentage (of soil particles) passing designated sieves is the percentage of the soil fraction less than 3 inches in diameter based on an oven-dry weight. The sieves, numbers 4, 10, 40, and 200 (USA Standard Series), have openings of 4.76, 2.00, 0.420, and 0.074 millimeters, respectively. Estimates are based on laboratory tests of soils sampled in the survey area and in nearby areas and on estimates made in the field. Three values are provided to identify the expected Low (L), Representative Value (R), and High (H).

Liquid limit and plasticity index (Atterberg limits) indicate the plasticity characteristics of a soil. The estimates are based on test data from the survey area or from nearby areas and on field examination. Three values are provided to identify the expected Low (L), Representative Value (R), and High (H).

References:

American Association of State Highway and Transportation Officials (AASHTO). 2004. Standard specifications for transportation materials and methods of sampling and testing. 24th edition.

American Society for Testing and Materials (ASTM). 2005. Standard classification of soils for engineering purposes. ASTM Standard D2487-00.

Report—Engineering Properties

Absence of an entry indicates that the data were not estimated. The asterisk ^{1*} denotes the representative texture; other possible textures follow the dash. The criteria for determining the hydrologic soil group for individual soil components is found in the National Engineering Handbook, Chapter 7 issued May 2007 (<http://directives.sc.egov.usda.gov/OpenNonWebContent.aspx?content=17757.wba>). Three values are provided to identify the expected Low (L), Representative Value (R), and High (H).

Engineering Properties—Washoe County, Nevada, South Part														
Map unit symbol and soil name	Pct. of map unit	Hydrologic group	Depth	USDA texture	Classification		Pct Fragments		Percentage passing sieve number—			Liquid limit	Plasticity index	
					Unified	AASHTO	>10 inches	3-10 inches	4	10	40			200
110—Jowec variant sandy loam, 4 to 8 percent slopes			<i>In</i>											
Jowec variant	85	D	0-10	Sandy loam	SM	A-2	0-0-0	0-3-5	90-95-100	90-95-100	50-55-60	15-25-35	20-25-31	NP
			10-20	Clay, sandy clay	CH, CL, SC	A-6, A-7	0-0-0	0-0-0	90-95-100	90-95-100	80-90-100	40-58-75	35-45-55	20-25-30
			20-66	Stratified sandy loam to clay loam	SC	A-2, A-6	0-0-0	0-0-0	90-95-100	90-95-100	55-68-80	30-40-50	20-28-35	10-15-20
171—Indian Creek gravelly sandy loam, 0 to 4 percent slopes														
Indian creek	85	D	0-3	Gravelly sandy loam	SC-SM, SC	A-1, A-2	0-0-0	0-3-5	60-70-80	50-60-70	35-45-55	15-25-35	20-23-25	5-8-10
			3-20	Gravelly clay, clay, sandy clay	CH	A-7	0-0-0	0-3-5	80-90-100	60-75-90	55-68-80	50-65-80	55-63-70	30-38-45
			20-25	Cemented material	—	—	—	—	—	—	—	—	—	—
			25-60	Stratified extremely gravelly loamy coarse sand to gravelly sandy clay loam	GC-GM, GM, GW-GM, GP-GC	A-1, A-2	0-0-0	5-18-30	35-45-55	30-43-55	15-20-25	5-10-15	20-25-30	NP-5-10

Engineering Properties--Washoe County, Nevada, South Part														
Map unit symbol and soil name	Pct. of map unit	Hydrologic group	Depth	USDA texture	Classification		Pct Fragments		Percentage passing sieve number--				Liquid limit	Plasticity index
					Unified	AASHTO	>10 inches	3-10 inches	4	10	40	200		
250—Cassiro gravelly sandy loam, 2 to 4 percent slopes			In				L-R-H	L-R-H	L-R-H	L-R-H	L-R-H	L-R-H		
Cassiro	85	D	0-15	Gravelly sandy loam	SM	A-1, A-2	0-0-0	0-3-5	65-73-80	55-63-70	30-40-50	15-23-30	21-28-35	NP
			15-45	Very gravelly sandy clay, very gravelly clay	GC, SC	A-2	0-0-0	5-10-15	50-63-75	40-45-50	25-35-45	15-25-35	25-38-50	10-18-25
			45-60	Bedrock	—	—	—	—	—	—	—	—	—	—
251—Cassiro gravelly sandy loam, 4 to 8 percent slopes														
Cassiro	85	D	0-15	Gravelly sandy loam	SM	A-1, A-2	0-0-0	0-3-5	65-73-80	55-63-70	30-40-50	15-23-30	21-28-35	NP
			15-45	Very gravelly sandy clay, very gravelly clay	GC, SC	A-2	0-0-0	5-10-15	50-63-75	40-45-50	25-35-45	15-25-35	25-38-50	10-18-25
			45-60	Bedrock	—	—	—	—	—	—	—	—	—	—
360—Pits														
Pits	100		0-60	Variable	GP	A-1	—	—	—	—	—	—	0-7-14	—
482—Holbrook cobbly loamy sand, 2 to 8 percent slopes														
Holbrook	85	A	0-10	Cobbly loamy sand	SM	A-1	0-0-0	15-25-30	75-85-90	50-70-70	25-33-40	10-15-20	18-24-30	NP
			10-60	Stratified stony sand to extremely gravelly loam	GM, SM	A-1, A-2	0-5-10	10-25-40	45-58-70	40-53-65	30-40-50	15-23-30	17-23-29	NP

Engineering Properties--Washoe County, Nevada, South Part														
Map unit symbol and soil name	Pct. of map unit	Hydrologic group	Depth	USDA texture	Classification		Pct Fragments		Percentage passing sieve number--				Liquid limit	Plasticity index
					Unified	AASHTO	>10 inches	3-10 inches	4	10	40	200		
930—Old Camp stony sandy loam, 15 to 30 percent slopes			In											
Old camp	85	D	0-2	Stony sandy loam	SM	A-1	1- 3- 5	5-10- 15	60-65- 70	55-60- 65	35-40- 45	15-20- 25	15-20 -25	NP-3 -5
			2-14	Very cobbly clay loam, extremely stony sandy clay loam, very stony clay loam	GC	A-2, A-6	15-15- 25	20-25- 30	40-48- 55	35-43- 50	30-38- 45	25-33- 40	30-35 -40	15-20-2 5
			14-24	Bedrock	—	—	—	—	—	—	—	—	—	—
971—Aladshi sandy loam, 2 to 4 percent slopes														
Aladshi	85	C	0-7	Sandy loam	SM	A-2	0- 0- 0	0- 3- 5	85-93-1 00	80-88- 95	50-58- 65	25-30- 35	20-23 -25	NP-3 -5
			7-34	Gravelly loam, sandy clay loam, sandy loam	CL, SC	A-6	0- 0- 0	0- 3- 5	80-88- 95	70-80- 90	55-65- 75	45-53- 60	25-30 -35	10-15-2 0
			34-60	Stratified extremely gravelly loamy sand to very gravelly loam	SM	A-1, A-2	0- 0- 0	5- 8- 10	60-68- 75	35-43- 50	25-33- 40	15-23- 30	20-23 -25	NP-3 -5

Data Source Information

Soil Survey Area: Washoe County, Nevada, South Part
 Survey Area Data: Version 12, Sep 12, 2016

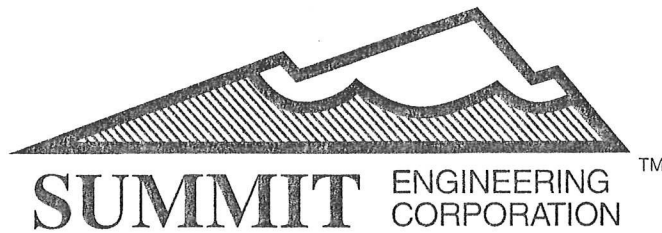

September 6, 2005

Job No. 21545

Mr. C. B. Maddox
5894 Sheep Drive
Carson City, Nevada 89701

RE: Updated Geotechnical Investigation – Cottonwood Creek
(Comstock Estates, Units 4-11, dated January 30, 1995)
Reno, Nevada

Dear Mr. Maddox:

Summit Engineering has completed a supplementary study to augment and to update the information provided in the previous soils report of this project site (Sheets 1 and 2). The supplemental study included review of the current grading plan to assure that depths of original exploration were adequate, updating the specifications to incorporate the *Standard Specifications for Public Works Construction (2004)*, replacing the 1992 date, and assessment of seismic risks using current standards.

The original field exploration test pits were located on and compared with the current grading plan. Depths of those test pits were determined to be adequate for the cuts and fills as planned.

For flexible pavement design, previous traffic information and subgrade resistance data were used to derive a section design (Appendix A). The resultant pavement section consisting of 4 inches asphaltic concrete on 6 inches aggregate base appears to be adequate for the proposed uses. All work shall comply with the *Standard Specifications for Public Works Construction (2004)*.

No soluble sulfate data were available. In order for the soils to be characterized as “negligible” per IBC 2003 standards (IBC 2003, Table 1904.3), the soils must contain less than 0.1% soluble sulfates. Supplemental sampling during grading is required in order to minimize adverse impacts to concrete improvements from soluble sulfate.

Three Quaternary faults have been mapped across the site by prior investigators (Sheet 3). These faults do not cut Holocene sediments, and have been classified previously as “inactive”. Additionally, a small, inactive, early Quaternary volcanic cone is situated approximately 0.5 mi north of the site. Literature reviewed included the prior geotechnical investigation by Summit Engineering and studies by the Nevada Bureau of Mines and Geology (Bell, 1984; Bonham and Bell, 1993; dePolo, 1996). The property, according to International Building Code 2003 maps (Sheets 4–6), may be subject to strong seismic acceleration, a minimum 0.65g ground acceleration, and therefore has a high probability for experiencing impact from a major seismic event. The effect of seismic shaking, therefore, is an important consideration.

There are no local codes that provide guidelines for the evaluation of seismic risk or surface rupture hazard associated with Quaternary (Holocene and Pleistocene) faults. The State of Nevada requires the use of seismic provisions set by the IBC, as well as adoptions of appropriate local standards (NRS 278.580.5). For the purposes of assessing seismic hazard and potential fault rupture hazard, standard engineering practice is to pursue the most diligent investigation of those faults deemed to be most likely to be active. Most

5405 Mae Anne Avenue • Reno, Nevada 89523 • (775) 747-8550 FAX (775) 747-8559
1421 E. Sunset Road, Suite 17 • Las Vegas, Nevada 89119 • (702) 252-3236 FAX (702) 252-3247
1150 Lamoille Highway • Elko, Nevada 89801 • (775) 738-8058 FAX (775) 738-8267
824 E. Aultman • Ely, Nevada 89301 • (775) 289-4445 FAX (775) 289-4043

WTM16-003 - EXHIBIT E

Mr. C.B. Maddox
 September 6, 2005
 Page 2

geological consultants in Nevada follow the conventions established by the Nevada Earthquake Safety Council, whose guidelines are based on the Alquist-Priolo Act of 1972 in California. Per these guidelines, faults with evidence of movement in Holocene time (past 12,000 years) are considered "active". Those faults with evidence of displacement during Pleistocene time (12,000 to 1,800,000 years ago) would be considered "potentially active". Active faults are afforded a greater degree of study and analysis than those regarded as potentially active. Normally, any fault suspected of being active, as demonstrated by offset of the argillic (topsoil) horizon, poses a greater risk to development and requires a minimum setback of 50 feet for occupied structures. The mapped faults that cross the site have been previously classified as "inactive". The seismic hazard at the Comstock Estates site is probably no greater than other comparable locations in the area that are located at comparable distances to similarly identified faults.

Occupied structures have been built over and adjacent to inactive faults in the greater Reno area for decades, without significant harm to residents from temblors affecting the area. Building codes have evolved in recent years to provide adequate structural protection to residents for the level of tremors experienced to date. Summit Engineering Corporation does not recommend siting occupied structures across any faults, regardless of age.

The site has soil profiles that range from E, soft soil, to D, stiff to dense soil. The following table summarizes seismic design parameters for the 2003 International Building Code criteria for structural design of the project:

IBC SEISMIC DESIGN

Site Class	E	D
Soil Profile Type	Soft Soil	Stiff Soil
Seismic Source Type	B	B
Soil Shear Wave Velocity (v_s)	<600 fps	600-1200
Standard penetration resistance (N)	<15 (est.)	15-50
Soil undrained shear strength (s_u)	<1000 psf	1000-2000
Site Coefficient (F_a) w/ short accel. (s_s)	0.9	1.0
Site Coefficient (F_v) w/ 1-sec. accel. (s_1)	2.4	1.5
Max. ground motion, 0.2-sec SA (S_s), %g	159.61	159.61
Max. ground motion, 1.0-sec SA (S_1), %g	64.07	64.07

Please note that the updated reference for all specifications in the initial report now are pursuant to *Standard Specifications for Public Works Construction (2004)*.

If you have any questions, please contact our office (775)-747-8550.

Sincerely,
SUMMIT ENGINEERING CORPORATION

Jack Glynn III, P.E.
 Geotechnical Division Manager



[Handwritten Signature]
 9-7-05
 Walter Martin, P. Geo.
 Staff Geologist

LIMITATIONS

This report is prepared solely for the use of Summit Engineering's client. Any other entity wishing to utilize this report must obtain permission from them prior to doing so. Our services consist of professional opinions and recommendations made in accordance with generally accepted soil and foundation engineering principles and practices. The analyses and recommendations contained in this report are based on our site reconnaissance, the information derived from our field exploration and laboratory testing, our understanding of the proposed development, and the assumption that the soil conditions in the proposed building and grading areas do not deviate from the anticipated conditions.

Unanticipated variations in soil conditions could exist in unexplored areas on the site. If any soil or groundwater conditions are encountered at the site that are different from those discussed in this report, our firm should be immediately notified so that our recommendations can be modified to accommodate the situation. In addition, if the scope of the proposed construction, including proposed loads or structural location, changes from that described in this report, our firm should be notified.

Recommendations made in this report are based on the assumption that an adequate number of tests and inspections will be made during construction to verify compliance with these recommendations. Such tests and inspections should include, but not necessarily be limited to, the following:

- . Review of site construction plans for conformance with soils investigation.
- . Observation and testing during site preparation, grading, excavation and placement of fill.
- . Observation and testing of materials and placement of asphalt concrete and site concrete.
- . Foundation observation and review.
- . Consultation as may be required during construction.

The findings in this report are valid as of the present date; however, changes in the conditions of the property can occur with the passage of time, whether they are due to natural processes or to the works of man on this or adjacent lands. In addition, changes in applicable or appropriate standards occur, whether they result from legislation or from the broadening of knowledge. Accordingly, the findings in this report might be invalidated, wholly or partially, by changes outside of our control.

REFERENCES

Bell, John W., 1984, Quaternary Fault Map of Nevada, Reno Sheet: Nevada Bureau of Mines and Geology, Reno.

Bonham, Harold F. and Bell, John W., 1993, Steamboat Quadrangle Geologic Map, Urban Area Series Map 4Fg: Nevada Bureau of Mines and Geology, Reno, 1 sheet.

DePolo, Craig M., 1996, Local Quaternary Faults and Associated Potential Earthquakes in the Reno and Carson City Urban Areas, Nevada, Final Technical Report: National Earthquake Hazards Reduction Program, Nevada Bureau of Mines and Geology, Reno.

Federal Emergency Management Agency, Flood Insurance Rate Map Washoe County, Nevada and Incorporated Areas: Map #32031C3011E.

<http://eqhazmaps.usgs.gov>

International Conference of Building Officials, 2003, International Building Code, Volume 2.

Naval Facilities Engineering Command, 1986, Soil Mechanics – Design Manual 7.01.

Naval Facilities Engineering Command, 1986, Foundations and Earth Structures – Design Manual 7.02.

Regional Transportation Commission of Washoe County, 2004, Standard Specifications for Public Works Construction: Regional Transportation Commission of Washoe County, Washoe County, City of Sparks, City of Reno, Carson City, City of Yerington; Reno, Nevada.

SUPPLEMENTAL APPENDIX

APPENDIX A

FLEXIBLE PAVEMENT DESIGN

Subgrade "R"-value = 87
 $M_R = 4.94 \times 10^4$

Untreated Aggregate Base 6.0 in. Thickness

MAAT 45°F

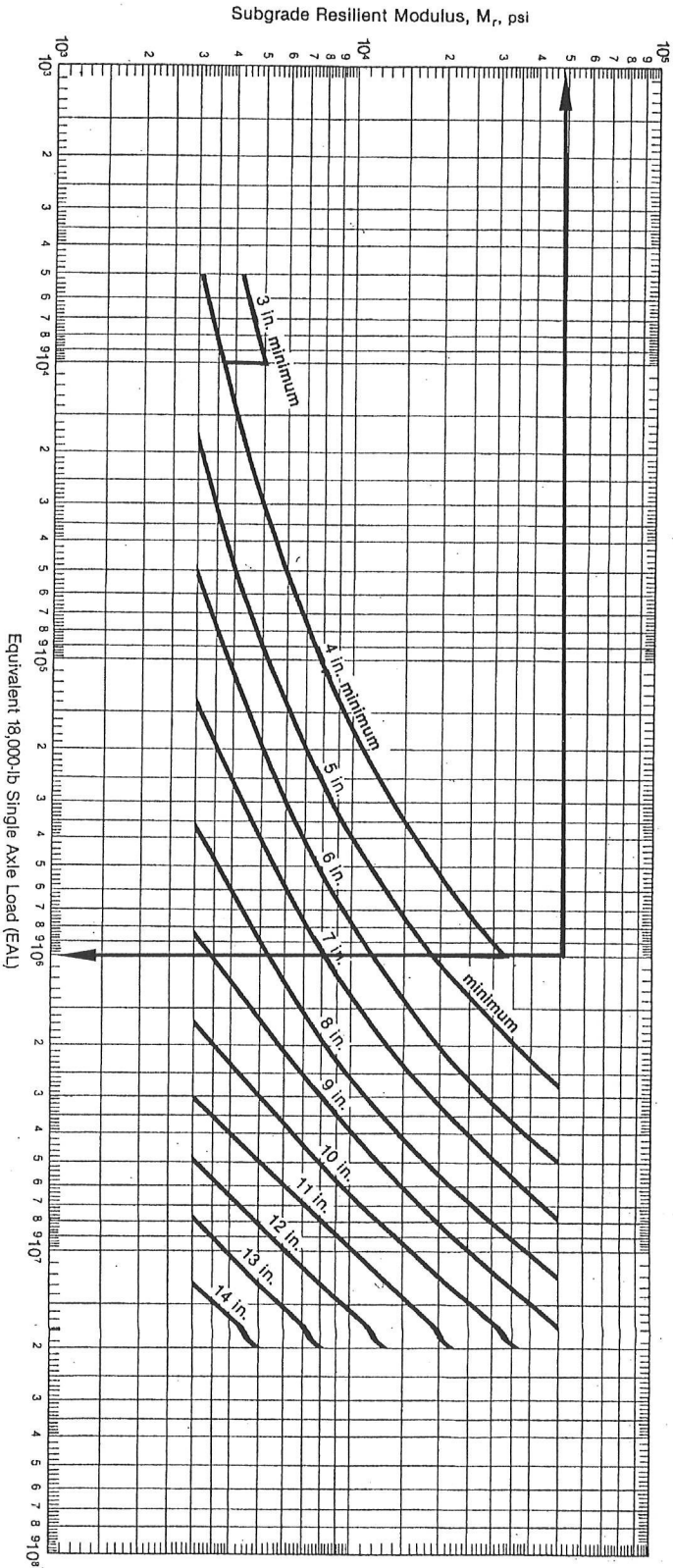

Design Chart A-23

Allowable ESALs = 10^6 for 4" AC on 6" Base per MS-1
 These amounts of ESALs are greater than
 expected for a local residential street.

FLEXIBLE PAVEMENT
 COMSTOCK ESTATES
 RENO, NEVADA

JOB NO.: 21545
 APPR.: JKG
 BY: WMM
 Copyright SUMMIT ENG 2005



SHEET 1
 OF APP.A

SHEETS

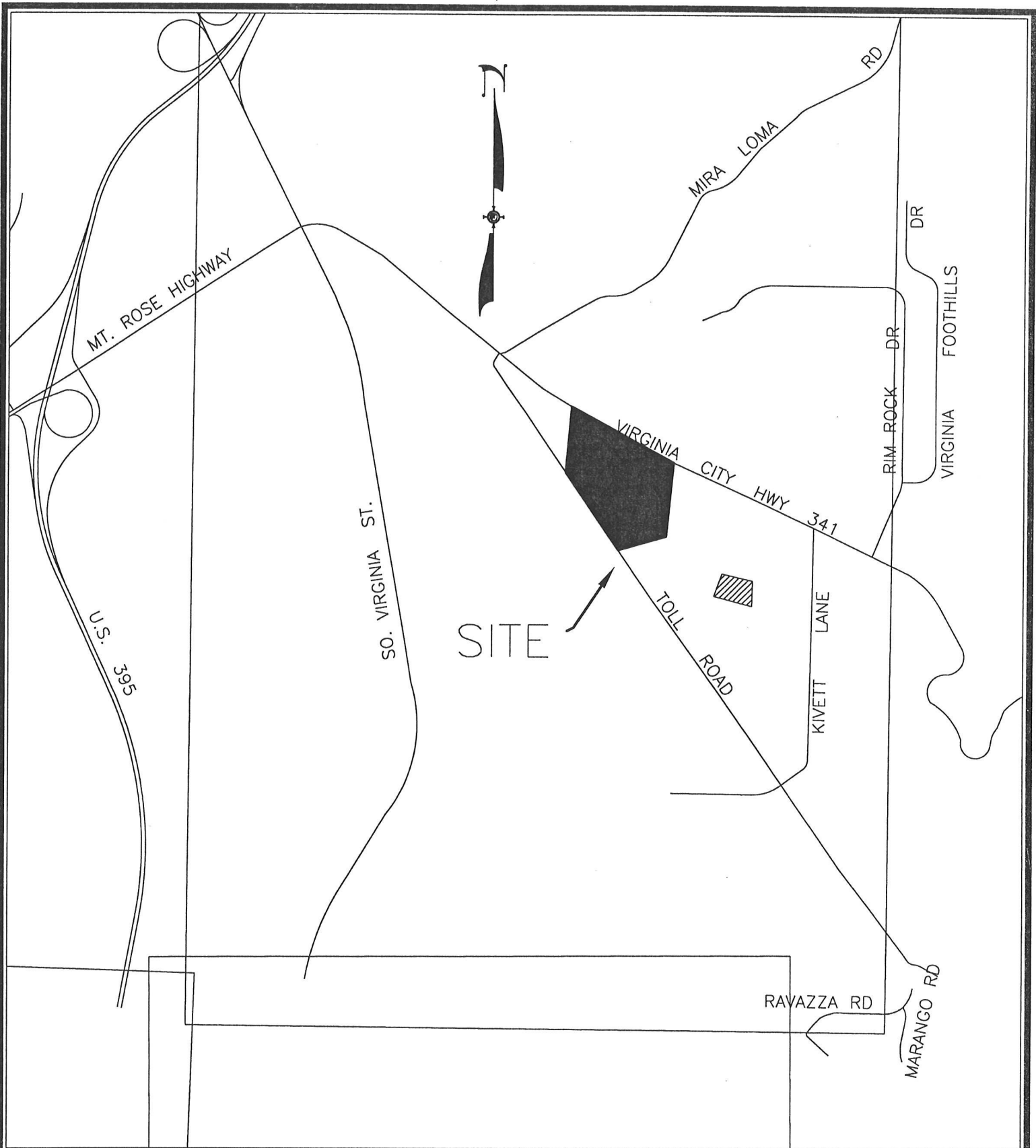

VICINITY MAP
COMSTOCK ESTATES
RENO, NEVADA

JOB NO.: 21545

APPR.: JKG

BY: WMM

Copyright SUMMIT ENG 2005

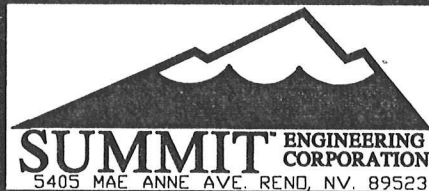

SHEET

1

OF

6

SITE



SITE MAP
COMSTOCK ESTATES
RENO, NEVADA

JOB NO.: 21545

APPR.: JKG

BY: WMM

Copyright SUMMIT ENG 2005



SHEET
2

OF
6

N:\DWGS\MISC\Walt\21545-site.DWG ~ 3:46 PM * 06-SEP-2005

WTM16-003 - EXHIBIT E

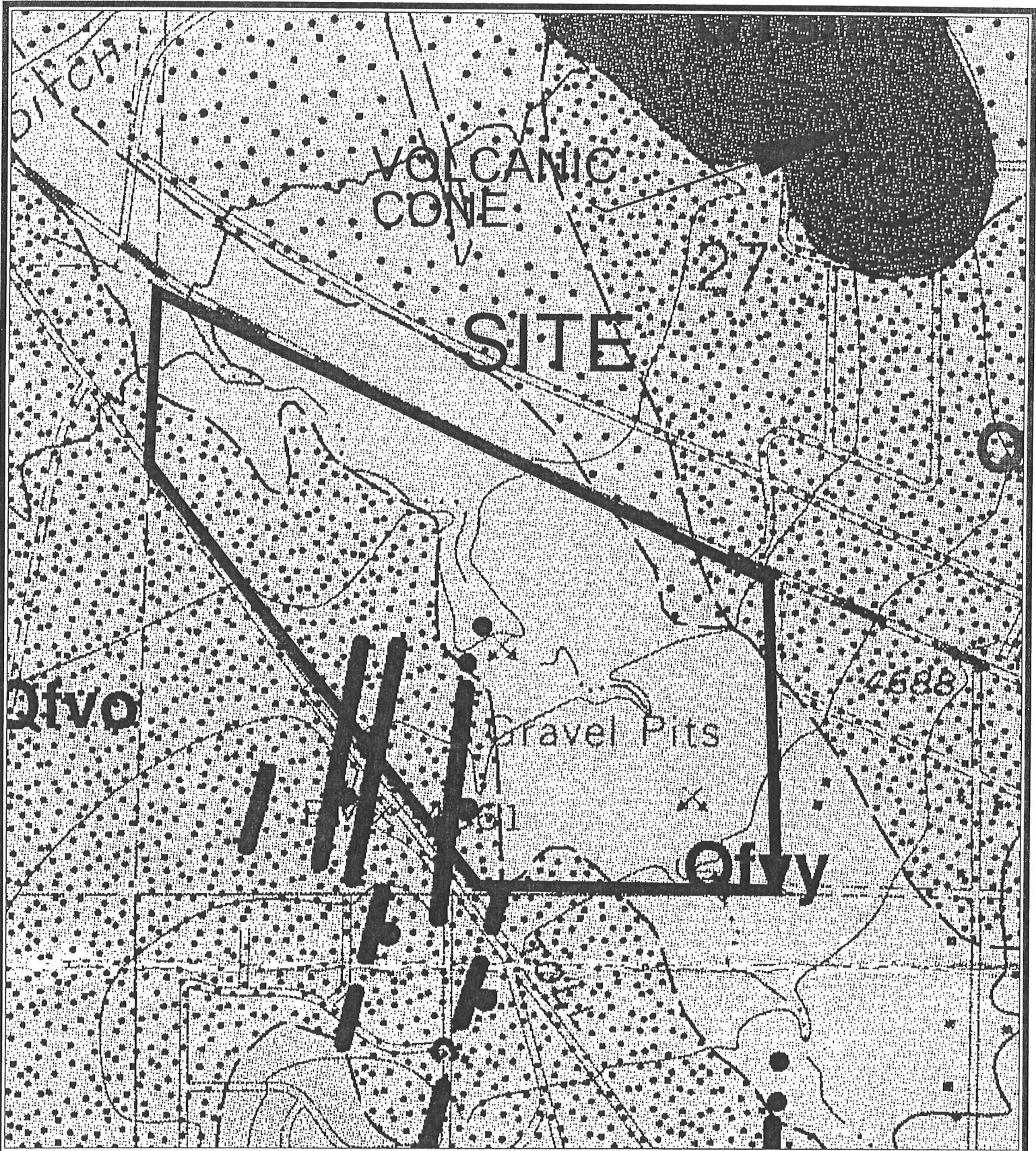

GEOLOGY MAP
 COMSTOCK ESTATES
 RENO, NEVADA

JOB NO.: 21545
 APPR.: JKG
 BY: WMM
 Copyright SUMMIT ENG 2005

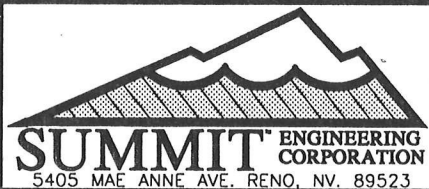

SHEET 3
 OF 6

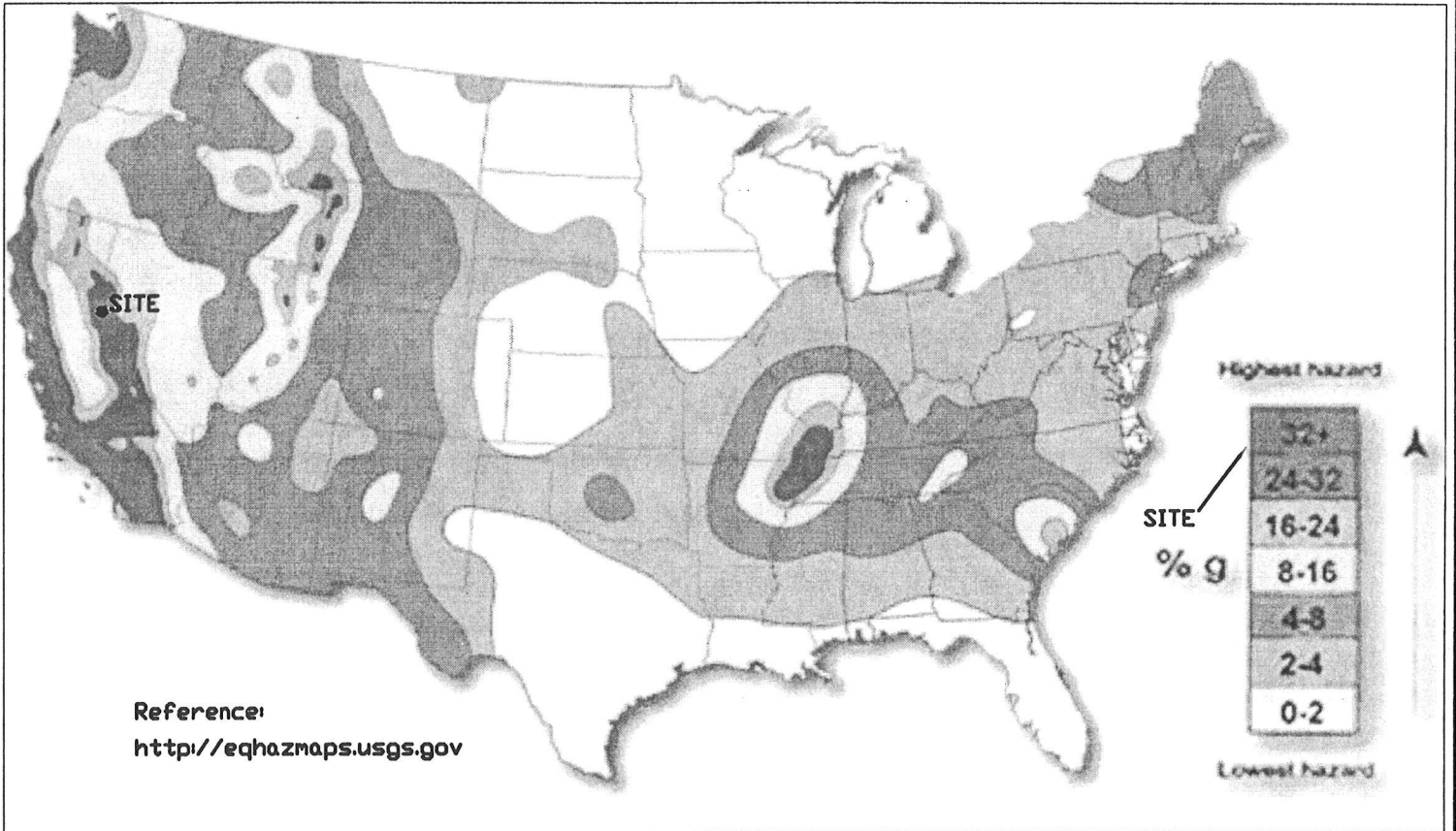

**SEISMIC HAZARD MAP
 COMSTOCK ESTATES
 RENO, NEVADA**

JOB NO.: 21545
 APPR.: JKG
 BY: WMM
 Copyright SUMMIT ENG 2005



SHEET 4
 OF 6

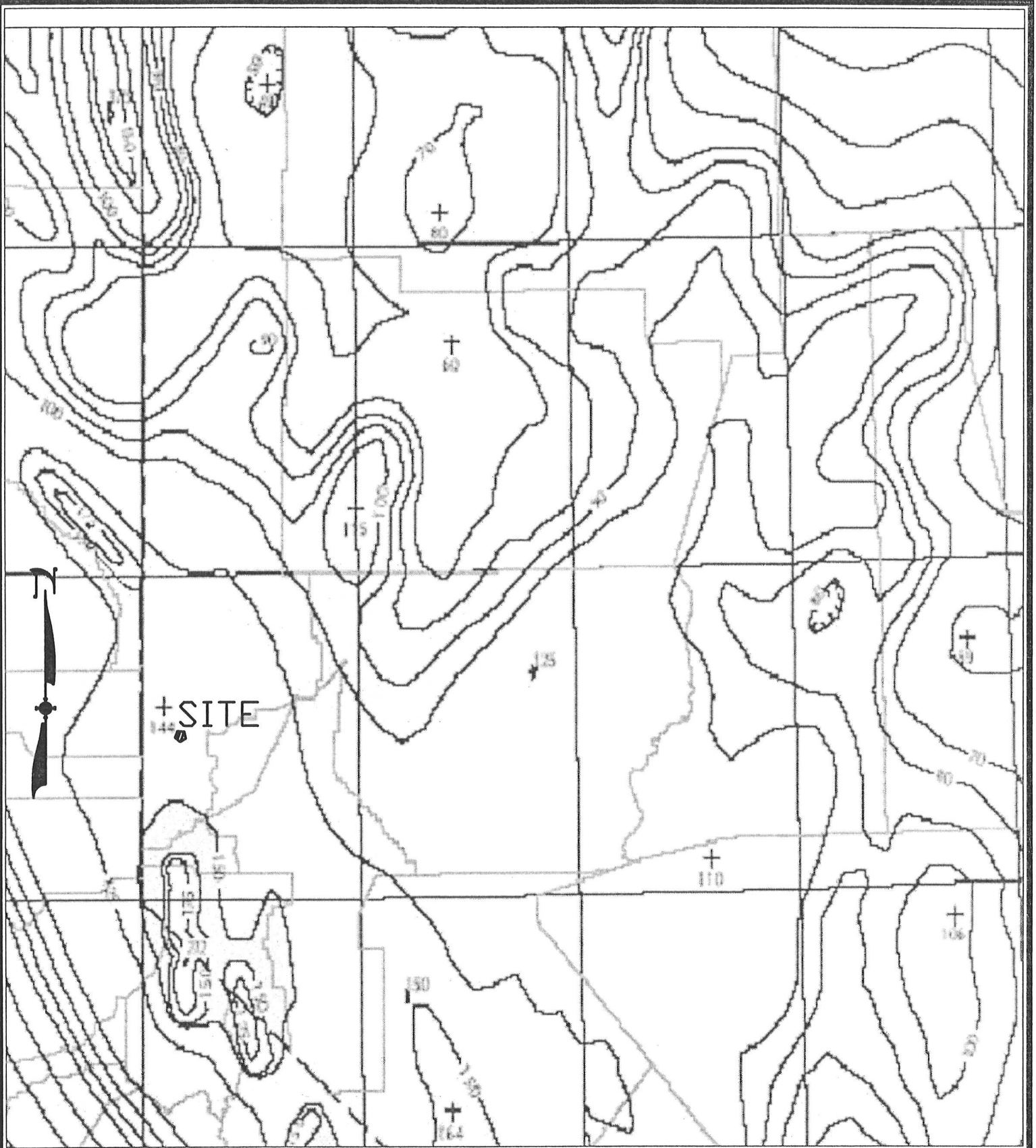

0.2 SEC a SEISMIC MAP
 COMSTOCK ESTATES
 RENO, NEVADA

JOB NO.: 21545
 APPR.: JKG
 BY: WMM
 Copyright SUMMIT ENG 2005

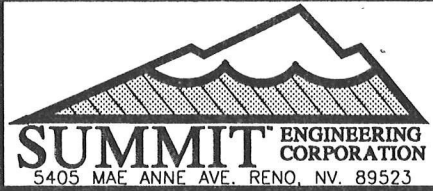

SHEET -
 5
 OF
 6

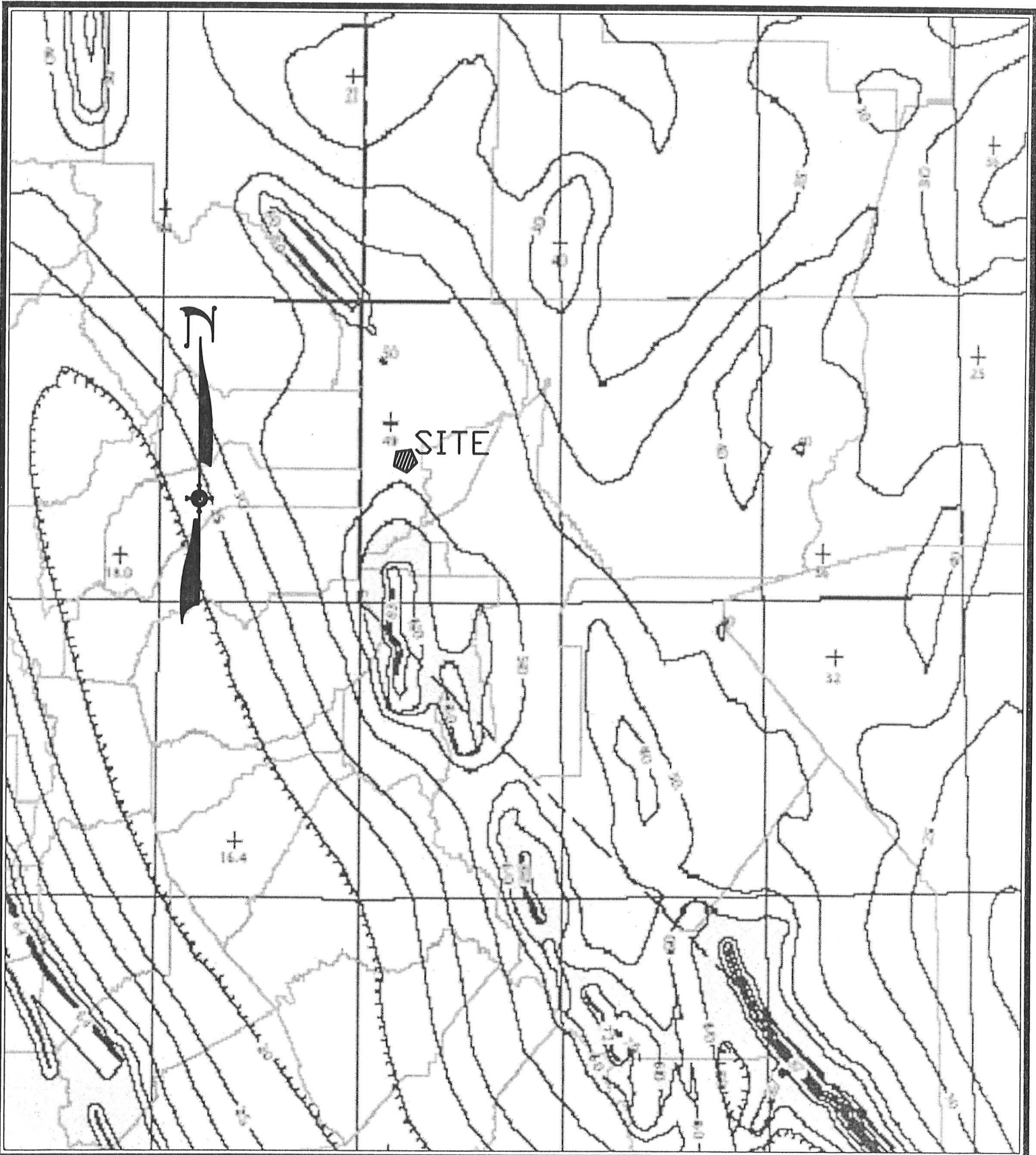

1-SEC a SEISMIC MAP
 COMSTOCK ESTATES
 RENO, NEVADA

JOB NO.: 21545
 APPR.: JKG
 BY: WMM
 Copyright SUMMIT ENG 2005



SHEET -
 6
 OF
 6

**GEOTECHNICAL INVESTIGATION
COMSTOCK ESTATES, UNITS 4 - 11
WASHOE COUNTY, NEVADA**

**File No. 21545
January 30, 1995**

Prepared For:

**C. B. Maddox
5894 Sheep Drive
Carson City, Nevada 89701**

**Linda A. Hansen
Staff Geotechnical Designer
Geotechnical Division**

Prepared By:

**Summit Engineering Corporation
5405 Mae Anne Avenue
Reno, Nevada 89523**

**Jack K. Glynn, III, P.E.
Project Manager
Geotechnical Division**

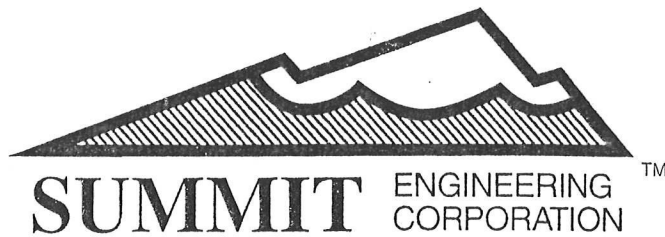

October 26, 2003

Job No. 21545

Mr. Ben Maddox
C.B. Maddox
5894 Sheep Drive
Carson City, Nevada 89701

RE: Geotechnical Investigation
Comstock Estates, Units 4-11

Dear Mr. Maddox:

It is our understanding that the tentative map for the above mentioned project is being submitted to the County for approval. For this purpose, the Geotechnical Investigation Report No. 21545 is applicable. However, once a final grading plan is completed and approved, this will need to be reviewed to insure the test pits were excavated to depths of the "cuts". If it is determined that the "cuts" are deeper than the test pit excavations, additional test pits will be required.

If you have any further questions, or need any additional information, please do not hesitate to contact our office.

Sincerely,

SUMMIT ENGINEERING CORPORATION

Mitch Burns, P.E.
Project Engineer

MB:bjg

j:\wpdata\mitch\21545.doc

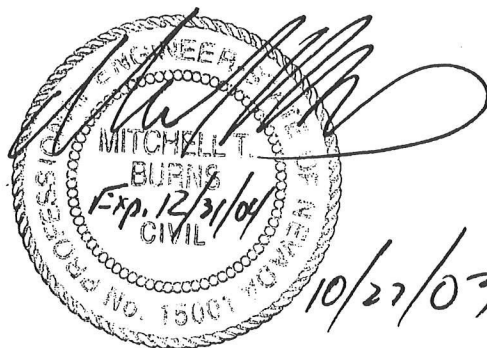

5405 Mae Anne Avenue • Reno, Nevada 89523 • (775) 747-8550 FAX (775) 747-8559
1421 E. Sunset Road, Suite 17 • Las Vegas, Nevada 89119 • (702) 252-3236 FAX (702) 252-3247
607 South Fifth Street • Elko, Nevada 89801 • (775) 738-8058 FAX (775) 738-8267
824 E. Aultman • Ely, Nevada 89301 • (775) 289-4445 FAX (775) 289-4043

WTM16-003 - EXHIBIT E

TABLE OF CONTENTS

I.	INTRODUCTION	1
A.	Project Description	1
B.	Purpose and Scope	1
C.	Field Exploration and Laboratory Testing	2
II.	DISCUSSION	3
A.	Site Description	3
B.	General Geology	3
C.	Regional Seismicity	4
D.	Subsurface Materials and Conditions	4
E.	Ground Water and Surface Hydrology	4
F.	Liquefaction Potential	5
III.	CONCLUSIONS AND RECOMMENDATIONS	6
A.	Foundation Considerations	6
B.	Asphaltic Concrete Design	6
C.	Native Soils	7
	LIMITATIONS	8
	APPENDIX A	10
1.0	General	10
2.0	Site Preparation and Earthwork	11
3.0	Fill Material	12
4.0	Earthwork and Fill Placement	13
5.0	Excavation and Slope Requirements	14
6.0	Foundations and Footing Design	14
7.0	Utility Trench Backfill	15
8.0	Concrete Slab-On-Grade & Flatwork Construction	16
9.0	Retaining Walls	18
10.0	Asphalt Concrete Pavement	19
11.0	Seismic Design	21
	APPENDIX B (ASPHALTIC CONCRETE DESIGN)	22
	Plates 1 through 24	

GEOTECHNICAL INVESTIGATION
COMSTOCK ESTATES, UNITS 4-11
WASHOE COUNTY, NEVADA

I. INTRODUCTION

A. **Project Description**

This report presents the results of a geotechnical investigation for the proposed Comstock Estates Units 4-11 development in Washoe County, Nevada. This development will include 156 residential homes. The site is located in Washoe County in Section 27 of Township 18 North, Range 20 East. This area lies south of State Route 341, and north and east of Toll Road. The site encompasses a total of approximately 84.6 +/- acres, and contains a proposed 156 units. Plate 1 provides a vicinity map and a Plate 2 provides a site plan.

This investigation provides site specific soil design criteria for the proposed single family residences. The recommendations of this report are made for structures that will have building wall loads of less than 2000 pounds per lineal foot and maximum column loads of 15 Kips. If any structures are to be constructed that will have heavier loads than those described or will have special foundation considerations not addressed in this report, the soil design criteria of this report should be reviewed by a geotechnical engineer.

B. **Purpose and Scope**

The purpose of this investigation was to determine subsurface soil conditions and to provide geotechnical design criteria based upon our findings for the proposed project. The scope of this

investigation included surface reconnaissance, subsurface exploration, analysis of field and laboratory data, research of pertinent geologic literature, and report preparation. This report provides conclusions and recommendations concerning:

- . General subsurface conditions and geology
- . Site preparation and earthwork
- . Engineering properties of the soils which will influence the design of the future structures, including:
 - . Bearing Capacities
 - . Settlement potential
 - . Lateral earth pressures
- . Asphalt concrete and concrete pavement
- . Seismic design criteria

C. Field Exploration and Laboratory Testing

Summit Engineering Corporation conducted the subsurface investigation by excavating a total of 16 test pits to a maximum depth of 11 feet. Geotechnical engineers logged the soils and subsurface conditions encountered. Plate 1 shows the vicinity map and Plate 2 presents the site map and the locations of the test pits. Plates 3 through 18 show the vertical profiles of the soils encountered. Plate 19 provides a key to the logs and a copy of the Unified Soil Classification System which was used to identify the site soils.

Representative bulk samples were obtained for laboratory testing. The laboratory testing program consisted of : 1) gradations, 2) moisture contents, and 3) Atterburg limits tests to confirm field soil classifications; and an 4) R-Value to evaluate the subgrade strength for pavement design. Results of the laboratory tests are shown on the test pit logs and are presented graphically on Plates 20 through 22.

II. DISCUSSION

A. Site Description

The subject property is currently undeveloped land covered with grasses and sage brush. The site is found north and east of Toll Road and south of State Route 341 (Geiger Grade). The highest elevations are found in the northeast at approximately 5152 feet above mean sea level. Single family residences are found to the south, west, and east.

B. General Geology

According to the Steamboat Quadrangle Geologic Map by Harold F. Bonham Jr. and John W. Bell (1993), the site is underlain by the alluvial-fan deposits of the Virginia Range, which is divided into Q_{fy} , Q_{fvi} and Q_{fvo} . These deposits are described as "Composed dominantly of subangular to subrounded clasts of gray to dark-gray andesite with varying proportions of white to red altered andesite clasts depending upon source areal; poorly to moderately stratified; poorly to very poorly sorted. From oldest to youngest, units comprise a descending set of successively inset and nested fans and stream terraces typically having little vertical separation. Similar geomorphic characteristics make differentiation very difficult without the use of pedologic data. Q_{fy} : light-brown to brown muddy, sandy, pebble gravel; locally cobble to boulder gravel. Soils have A-C to cambic profiles. Stippled where deposit is dominantly a pebble sand derived from reworking of older Q_e deposits. Where bouldery, commonly displays bar-and-channel microtopography. Q_{fvi} : light-brown to brown muddy, sandy, cobble to boulder gravel; maximum boulder diameter of 1 m. Typically contains a well-developed argillic soil about 30 cm thick. Q_{fvo} : light-brown to brown muddy, sandy, cobble to boulder gravel; maximum boulder diameter 1 m. Surface clasts are strongly weathered. Soils contain a well-developed argillic horizon ranging from 0.5 to 1 meter thick, locally underlain by a carbonate- and silica-cemented duripan as much as 1 m thick. East of Steamboat Creek in the Steamboat Springs area, unit forms a predominant terrace which is stratigraphically equivalent to Q_{dm} ." From an engineering standpoint, the native site soils should provide adequate bearing support for the proposed structures and site improvements.

C. Regional Seismicity

The subject property, as well as the entirety of the Reno area, lies within the Uniform Building Code Seismic Zone 3. This zone has a high probability for a moderate seismic event. Structures in this area may be subject to damage such as that occurring during an average event equivalent to a Modified Mercalli Intensity of VII. This size event approximately correlates to a Richter Magnitude of 6.0. Plate 23 shows a 1991 UBC Seismic Zone Map for Nevada.

According to the Steamboat Quadrangle Geologic Map by Harold F. Bonham, Jr. and John W. Bell (1993), the three Quaternary faults are found on southern portion of the site, trending from approximately the north to the south. These faults are found in Pleistocene-aged deposits, and do not pass through the Holocene deposits; therefore, the age of these faults can be approximated as Pleistocene. According to the Quaternary Fault Map of Nevada - Reno Sheet, by John W. Bell (1984), these faults have been approximately dated as experiencing last movement in the Pleistocene or greater than 100,000 thousand years ago; consequently, it can be considered inactive. An active fault is one that has experienced movement during the Holocene or in the past 12,000 years. The nearest Holocene fault is located approximately 4 miles to the west along the Carson Range front.

D. Subsurface Materials and Conditions

The subsurface investigation encountered the Alluvial-fan deposits of the Virginia Range (Q_{fvy} , Q_{fvi} , and Q_{fvo}) which is consistent with the general geology of the area. Tests pits 3, 4, 5, 6, 7, and 13 encountered a surface layer (up to 2.5 feet below ground surface) of medium to high plasticity sandy clays. Test pits 8, 9, 15, and 16 encountered a surface layer of sands and silty sands. All test pits contained a sandy cobble to boulder gravel, from the surface or below the aforementioned surface layers, to the total depth of the pits. Please refer to Plates 3 through 18 for more details.

E. Ground Water and Surface Hydrology

Groundwater was not encountered in any of the test pits made on the site. The depth of the test pits extended to a maximum depth of 11 feet below ground surface. Groundwater is not expected to be a problem on the site. The portion of the site along Bailey Canyon Creek has been delineated

by the Federal Emergency Management Agency (FEMA) as being located in Flood Hazard Zone A3. This zone is described as "Areas of 100-year flood; base flood elevations and flood hazard factors determined." The portion of the site adjacent to Bailey Canyon Creek has been delineated by the FEMA as being in located in Flood Hazard Zone B. This zone is described as "areas between limits of the 100-year flood and 500-year flood; or certain areas subject to 100-year flooding with average depths less than one foot or where the contributing drainage area is less than one square mile; or areas protected by levees from the base flood".

F. Liquefaction Potential

During earthquakes the shaking of the ground may cause a loss of strength or stiffness that results in settlement of buildings, landslides, structural failures, and other hazards. The process leading to such loss of strength or stiffness is called liquefaction. It is a phenomenon associated primarily, but not exclusively, with saturated cohesionless soils.

Liquefaction is brought about by an increase in pore water pressure during dynamic loading of an earthquake. When the increased pore water pressure reaches the value of the overburden stress on the soil, the supporting strength of the soil is reduced to near zero. The liquefied soils have little or no bearing capacity, and can densify causing settlement of foundations or differential settlement of floor slabs.

Loose granular soils without cohesive fines are most susceptible to the rapid buildup of pore pressure. Other factors affecting the degree of pore pressure build up include: the amplitude of the oscillatory straining; the past history of stressing; the size, shape, and gradation of particles; the confining pressure acting on the soil; the age of the deposit; the fabric of the soil; the depth to groundwater; and the shear strength of the soil.

Very limited amounts of potentially liquefiable soils were encountered on site. These soils (clean sands) were mainly located in limited surficial deposits. Due to the medium dense to dense nature of soils, and the depth to groundwater being deep, we believe the potential for damage to any structure due to liquefaction to be very minimal.

III. CONCLUSIONS AND RECOMMENDATIONS

From a geotechnical engineering standpoint, it is our opinion that the subject site is suitable for the construction of future residential development provided that the recommendations contained in this report, and in the attached earthwork specifications, are incorporated into the project design and construction. The following sections present conclusions and recommendations concerning the proposed project.

A. Foundation Considerations

Analysis obtained from field and laboratory testing indicates unsaturated native soils can support up to 3000 pounds per square foot for dead plus long term live loads, on spread type footings with less than 1 inch of total settlement and less than 1/2 inch of differential settlement across the length of the structures. This assumes that all moderately to highly plastic clays, which were found down to 2.5 feet in depth (possibly deeper in unexplored areas), will require complete removal for all footings and flatwork and replaced with structural fill placed in accordance with Appendix A.

B. Asphaltic Concrete Design

The given asphalt pavement section assumes that the sandy clays will be removed and the native sandy gravels will be used beneath roadways and parking lot/entrances areas. It assumes that any existing fill, loose organic topsoil or near surface clayey soils are removed, and that native soil is scarified and recompacted to a depth of six inches. Any fill placed in overexcavated areas should meet the requirements for structural fill. If plastic soil is encountered, overexcavation and replacement of this soil with structural fill is recommended to a depth of 2 feet, compacted in accordance with recommendations in Appendix A of this report. The pavement section provided assumes a 20-year average design period. Subgrade material shall be compacted to 90 percent, and aggregate base material shall be compacted to 95 percent relative compaction (ASTM D-1557).

The pavement section designed was based on an average of 10 trip-ends per unit per day giving a AADT (average daily traffic) of 1560 vehicles per day. The calculated equivalent EAL (equivalent axial load) is 1.43×10^5 for the design life of 20 years. An R-value of 87 was used, which was

obtained from the laboratory analysis presented on Plate 23 . This R-value is equivalent to a resilient modulus (M_r) of 4.94×10^4 psi. The following sections are recommended (see Appendix B):

RECOMMENDED PAVEMENT SECTION THICKNESS

LOCATION	ASPHALT	TYPE II BASE
Public Streets	4"	6"

All public streets dedicated to the City of Reno have a required minimum of 4 inches of asphaltic concrete on 6 inches of base material.

* See Appendix B for calculations.

C. Native Soils

The native alluvial soils may be re-used as structural fill, after screening, provided they are tested and meet the requirements stated in Appendix A for structural fill. From a geotechnical engineering standpoint, it is our opinion that the subject site is suitable for the construction of the proposed development provided that the recommendations contained in this report, and in the attached earthwork specifications, are incorporated into the project design and construction.

LIMITATIONS

Our services consist of professional opinions and recommendations made in accordance with generally accepted soil and foundation engineering principles and practices. The analyses and recommendations contained in this report are based on our site reconnaissance, the information derived from our field exploration and laboratory testing, our understanding of the proposed development, and the assumption that the soil conditions in the proposed building and grading areas do not deviate from the anticipated conditions.

Unanticipated variations in soil conditions could exist in unexplored areas on the site. If any soil or groundwater conditions are encountered at the site which are different from those discussed in this report, our firm should be immediately notified so that our recommendations can be modified to accommodate the situation. In addition, if the scope of the proposed construction, including proposed loads or structural location, changes from that described in this report, our firm should be notified.

Recommendations made in this report are based on the assumption that an adequate number of tests and inspections will be made during construction to verify compliance with these recommendations. Such tests and inspections should include, but not necessarily be limited to, the following:

- . Review of site construction plans for conformance with soils investigation.
- . Observation and testing during site preparation, grading, excavation and placement of fill.
- . Observation and testing of materials and placement of asphalt concrete and site concrete.
- . Foundation observation and review.
- . Consultation as may be required during construction.

The findings in this report are valid as of the present date; however, changes in the conditions of the property can occur with the passage of time, whether they be due to natural processes or to the works of man on this or adjacent lands. In addition, changes in applicable or appropriate standards occur, whether they result from legislation or from the broadening of knowledge. Accordingly, the findings in this report might be invalidated, wholly or partially, by changes outside of our control.

APPENDIX A
SPECIFICATIONS FOR
SITE PREPARATION, EXCAVATION, RECOMPACTION
STRUCTURAL FILL, and SUBGRADE PREPARATION

1.0 GENERAL

- 1.1 Standard Specifications - Where referred to in these specifications, "Standard Specifications" shall meet the Standard Specifications for Public Works Construction sponsored and distributed by Washoe County, City of Reno, City of Sparks, et. al. (1992).
- 1.2 Scope - All work shall be done in accordance with the standard Specifications except as may be modified by the specifications outlined below. The work done under these specifications shall include clearing, stripping, removal of unsuitable material, excavation and preparation of natural soil, placement and compaction of on-site and/or imported fill material, or as specifically referred to in the plans or specifications.
- 1.3 Geotechnical Engineer - When used herein, Geotechnical Engineer shall mean the engineer or a representative under the engineer's supervision. The work covered by these specifications shall be inspected by a Geotechnical Engineer, who shall be retained by the Owner. The Geotechnical Engineer will be present during the site preparation and grading to inspect the work and to perform the tests necessary to evaluate material quality and compaction. The Geotechnical Engineer shall submit a report to the Owner, including a tabulation of all tests performed.
- 1.4 Soils Report - A "Soil Investigation" report, prepared by Summit Engineering Corporation, is available for review and may be used as a reference to the surface and subsurface soil and groundwater conditions on this project. The Contractor shall make his own interpretation with regards to the methods and equipment necessary to perform the excavations.

- 1.5 Percent Compaction - Where referred to herein, percent compaction shall mean the in-place dry unit weight of soil expressed as a percentage of the maximum dry unit weight of the same material, as determined by ASTM D-1557, compaction test procedure. Optimum moisture content is the moisture content corresponding to the maximum dry density determined by the ASTM test method D-1557.

2.0 SITE PREPARATION AND EARTHWORK

- 2.1 All earthwork and site preparation should be performed in accordance with the requirements of this report and attached specifications, and the "Standard Specifications For Public Works Construction" sponsored and distributed by Washoe County, City of Sparks, City of Reno, et.al. (1992).
- 2.2 Clearing - Areas to be graded shall be cleared of existing brush and debris. These materials shall be removed from the site by the Contractor.
- 2.3 Stripping - Surface soils containing roots and organic matter shall be stripped from areas to be graded and stockpiled or discarded as specified by the plans or specifications. In general, the depth of stripping of the topsoil will be approximately 6 to 8 inches. Where required, deeper stripping, to remove weak soils or accumulations of organic matter, shall be performed when determined by the Geotechnical Engineer. Strippings shall be removed from the site or stockpiled at a location specified by the plans.
- 2.4 Dust Control - The contractor shall prevent and maintain control of all dust generated during construction in compliance with all federal, state, county, and city regulations. The project specifications should include an indemnification by the contractor of the engineer and owner for all dust generated during the entire construction period.
- 2.5 Materials - All material not suitable for use as structural fill, shall be removed from the site by the Contractor, or placed in non-structural fill areas. The Geotechnical Engineer shall determine the suitability of material for reuse as structural fill.

- 2.6 Ground Surface - The ground surface exposed by stripping and/or excavation shall be scarified to a depth of 6 inches, moisture conditioned by aerating or adding water, and compacted to 90 percent relative compaction (ASTM D 1557), unless otherwise specified. Compaction of the ground surface shall be approved by the Geotechnical Engineer.
- 2.7 Backfill of test pits - Our exploration pits and previous pits were backfilled without mechanical compaction. In building and flatwork areas, backfill in the pits should be removed and replaced with approved, compacted materials.

3.0 FILL MATERIAL

- 3.1 Fill material shall be free of perishable, organic material and rocks over six inches in largest diameter. Rock used in the fill shall be placed in such a manner that no voids are present, either between or around the rock, after compacting the layer.
- 3.2 Structural Fill - Material shall consist of suitable non-expansive soils having a liquid limit less than 40, and a plasticity index less than 12. The gradation requirements shall be as follows:

<u>Sieve Sizes</u>	<u>Percentage Passing (by weight)</u>
4"	100
3/4"	70 - 100
40	15 - 70
#200	5 - 25

Materials not meeting the above requirements may be suitable for use as structural fill at the discretion of the Geotechnical Engineer. Samples of imported fill proposed for use as structural fill shall be submitted to the Geotechnical Engineer and approved before it is delivered to the site.

3.3 Rock Fill - Fill material containing over 25 percent (by volume) of rock larger than 6 inches in greatest dimension is defined as rock fill. Rock fill located three feet or more below finished grade may be constructed in loose lifts up to the maximum size of rock in the material but not exceeding two feet in thickness. The interstices around the rock in each rock fill lift shall be filled with granular material and compacted to the satisfaction of the Geotechnical Engineer. Rock larger than 12 inches in greatest dimension shall not be allowed in the rock fill without approval of the Geotechnical Engineer. Rock larger than 6 inches shall not be placed in the upper 1 foot of structural fill.

4.0 EARTHWORK AND FILL PLACEMENT

4.1 Placement - Fill material shall be placed in layers that shall not exceed 8 inches of compacted thickness, unless otherwise approved by the Geotechnical Engineer. Each layer shall be evenly spread and moisture conditioned as necessary. Unless otherwise specified, each layer of earth fill shall be compacted to 90 percent relative compaction. Compaction shall be approved by the Geotechnical Engineer. Rock fill shall be placed in accordance with the appropriate sections of the Standard Specifications. Rock fill placement shall be verified by the Geotechnical Engineer. Full time inspection is required unless otherwise approved.

4.2 Keyways - Where the fill extends onto native slopes with gradients greater than 5:1, the fill shall be keyed into the native soils. The keys will have a minimum width of 8 feet and constructed with a minimum 5% slope into the hillside.

4.3 Compaction Equipment - The Contractor shall provide and use equipment of a type and weight suitable for the conditions encountered in the field. The equipment shall be capable of obtaining the required percent of compaction in all areas including those that are inaccessible to ordinary rolling equipment.

4.4 Reworking - When, in the judgement of the Geotechnical Engineer, sufficient compaction effort has not been used, or where the field density tests indicate that the

required compaction or moisture content has not been obtained, fill materials shall be reworked and compacted as needed to obtain the required density and moisture content. This reworking shall be accomplished prior to the placement of additional fill.

- 4.5 Unstable Areas - If pumping or other indications of instability are noted, fill materials shall be evaluated by the Geotechnical Engineer and be left to dry; reworked; or removed, replaced, and compacted as needed to obtain the required density and moisture content. This work shall be accomplished prior to the placement of additional fill.

5.0 EXCAVATION AND SLOPE REQUIREMENTS

- 5.1 Finished cut and fill slopes should not exceed ratios of two horizontal to one vertical. Slopes steeper than three horizontal to one vertical or more than ten feet in height should be protected from erosion using either rip-rap, vegetation, or a similar designated and acceptable means meeting the City of Reno or Washoe County standards.
- 5.2 Temporary, unsupported construction slopes less than ten feet in height may stand at a slope as steep as 1:1 (H:V) provided that the length of the unsupported slope does not exceed twenty feet. These temporary slopes should not remain unsupported for extended periods of time.

6.0 FOUNDATIONS AND FOOTING DESIGN

- 6.1 Spread type continuous and column footings should be designed to impose a maximum net dead plus long term live load of 3000 pounds per square foot. Net bearing pressures up to one-third in excess of the given bearing value are permitted for transient live loads from wind and earthquake. Footing widths should be designed based upon these bearing pressures and design loads; however, in no case should they

be less than 1 foot wide for single story structures and 15 inches wide for two story structures. Isolated interior footings should also be a minimum of 15 inches wide.

- 6.2 Exterior footings should be embedded a minimum of 24 inches below the lowest adjacent final compacted subgrade to provide adequate frost protection and confinement. Isolated interior footings, where subject to any lateral loads, should be founded at least one foot below interior grade.
- 6.3 Passive soil resistance to lateral footing pressures may be calculated using an equivalent fluid weight of 400 pounds per cubic foot not exceeding 4000 pounds per cubic foot and a base coefficient of friction of 0.35. Active soil pressure may be calculated by using an equivalent fluid weight of 35 pounds per cubic foot.
- 6.4 Backfill placed around the footing excavations or formed footings should be compacted to at least 90 percent relative compaction.
- 6.5 All footing excavations should be clear of loose material prior to placement of concrete. All soil or fill material in the bottom of the footing excavation should be recompacted to at least 90 percent compaction.

7.0 UTILITY TRENCH BACKFILL

- 7.1 Material - Bedding material shall consist of clean, granular material having a sand equivalent of not less than 30, and 100 percent passing the 3/8 inch sieve. Backfill in the remainder of the trench shall consist of material meeting the requirements of structural fill.
- 7.2 Placement and Compaction - Bedding material shall first be placed so that the pipe is supported for the full length of the barrel with full bearing on the bottom segment of the pipe equal to a minimum of 0.4 times the outside diameter of the barrel. Bedding shall also extend to one foot above the top of the pipe. Pipe bedding within 6 inches of the pipe shall be placed in thin layers not exceeding 8 inches in loose

thickness, conditioned to the proper moisture content for compaction, and compacted to at least 90 percent compaction. All other trench backfill shall be placed in thin layers not exceeding 8 inches in loose thickness, conditioned to the proper moisture content, and compacted as required for adjacent fill, or if not specified, to at least 90 percent compaction in areas under structures, utilities, roadways, parking areas, and concrete flatwork. The top 6" under roadways and parking shall be compacted to 95%. In undeveloped areas trench backfill may be compacted to 85 percent relative compaction.

- 7.3 Drain Rock - Any necessary subsurface drainage systems shall use drain rock conforming to the following Type 2 gradation:

<u>Sieve Sizes</u>	<u>Percentage Passing (by weight)</u>
1"	100
3/4"	90-100
3/8"	20-55
No. 4	0-10

8.0 CONCRETE SLAB-ON-GRADE AND FLATWORK CONSTRUCTION

- 8.1 Slab-on-grade - When used in this report, slab-on-grade shall refer to all interior concrete flatwork including floors and garage slabs.
- 8.2 Concrete flatwork - A general term, flatwork refers to all exterior concrete site work including sidewalks, driveways, and patios.
- 8.3 Subgrade - Subgrade beneath concrete flatwork and slabs-on-grade shall be compacted to 90 percent compaction. In areas where dynamic loading (vehicular traffic) occurs, the subgrade shall be compacted to 95% relative compaction. Compaction shall be approved by the Geotechnical Engineer.

- 8.4 Overexcavation - Expansive soils within two feet of flatwork or slab-on-grade shall be overexcavated to a depth of two feet (unless otherwise stated) below the bottom of the base material. Overexcavations should extend at least two feet laterally beyond the edge of the flatwork/slab-on-grade section.
- 8.5 Base - Base material shall be a minimum of 6 inches thick and be compacted to 95 percent relative compaction. Compaction shall be approved by the Geotechnical Engineer. Type 2 Class B aggregate base or pit run gravel meeting the following requirements shall be used:

<u>Sieve Size</u>	<u>Percentage Passing (by weight)</u>
1"	100
3/4"	90-100
No. 4	35-65
No. 16	15-40
No. 200	2-10

- 8.6 Concrete slab thickness and compressive strength requirements shall be in accordance with design criteria provided by the Structural Engineer. Minimum slab thickness and compressive strength shall be in accordance with the requirements of the City of Reno.
- 8.7 Concrete work shall conform to all requirements of ACI 301-84, Specifications for Structural Concrete for Buildings, except as modified by supplemental requirements.
- 8.8 Type II Portland Cement shall be used for all concrete slabs and flatwork.
- 8.9 To facilitate curing of the slab, base materials shall be kept moist until placement of the concrete.

- 8.10 Excessive slump (high water:cement ratio) of the concrete and/or improper curing procedures used during hot or cold weather could lead to excessive shrinkage, cracking or curling of slabs and other flatwork.
- 8.11 Concrete Specifications - For concrete curbs, gutters, sidewalks, driveways, and alley returns, the following specifications are required:

Minimum 28-day compressive strength	4,000 psi
Sacks cement per cubic yard concrete	6-8
Maximum gallons water per sack cement	5
Percent air entrainment	5%-7%
Slump range, inches	1-4

Admixtures - All admixtures shall be incorporated in the mix design and approved by the Geotechnical Engineer.

Finishing - All finishing shall be done in the absence of bleed water. No water shall be added to placed concrete during finishing.

9.0 RETAINING WALLS

- 9.1 Footings for continuous strip type retaining walls should be placed at least 24 inches below the lowest adjacent finished grade to provide for confinement and to minimize settlement. The footings should be designed using an allowable soil bearing pressure of 3000 psf.
- 9.2 Retaining walls should be designed for an active lateral earth pressure of 35 pounds per cubic foot, a passive lateral earth pressure of 400 pounds per cubic foot, and a base coefficient of 0.35.
- 9.3 Concrete for the retaining walls should be poured against undisturbed soils, if possible. If forms are used for the footings, they should be backfilled with material

taken from the excavation and recompact to at least 90 percent compaction based on the ASTM D1557-78 test method.

- 9.4 In addition to active pressure from the soil, the effects of any surcharge from existing adjacent structures or roadways should be included in calculating lateral pressures on the retaining wall.
- 9.5 The design pressures given assume that the soils retained are granular and non-expansive and free draining.
- 9.6 Backfill should be lightly compacted to 85 percent relative density as the use of heavy compaction equipment could easily cause loads exceeding the designed lateral pressures which may result in wall failure. If moisture is encountered in the excavation, weep holes or a continuous drain along the base of the wall is recommended.
- 9.7 If moisture is encountered in the excavation or it is anticipated that surface moisture will seep down and be retained behind the wall, weep holes or continuous drain along the base of the wall is recommended.
- 9.8 City of Reno Standards require a concrete interceptor swale at the top of all retaining walls.

10.0 ASPHALT CONCRETE PAVEMENT

- 10.1 Material and Procedure - The asphalt-concrete material and placement procedures shall conform to appropriate sections of the "Standard Specifications". Aggregate materials for asphalt concrete shall conform to the requirements listed for Type 2 Plantmix Aggregate in Section 200.02.02 of the "Standard Specifications, 1992". The Contractor shall submit a proposed asphalt-concrete mix design to the Geotechnical Engineer for review and approval prior to paving. The mix design shall be based on

the Rice Method. Asphalt materials should be compacted to a minimum 92 percent of its maximum density per the Rice Method.

- 10.2 Subgrade Preparation - After completion of the utility trench backfill and prior to the placement of aggregate base the upper 6 inches of finished subgrade soil or sub-base material shall be uniformly compacted to at least 95 percent compaction. This may require scarifying, moisture conditioning and compacting.
- 10.3 Aggregate Base Rock - After the subgrade is properly prepared, the aggregate base material shall be placed uniformly on the approved subgrade. Aggregate base shall be placed in such a manner as to prevent segregation of the different sizes of material and any such segregation, unless satisfactorily corrected, shall be cause for rejection at the discretion of the Geotechnical Engineer. The aggregate base material shall be spread for compaction in layers not to exceed six inches, moisture conditioned as necessary, and compacted to at least 95 percent compaction. Aggregate base materials shall meet the requirements of Section 200.01.03 of the "Standard Specifications, 1992" for Type I, Class A or Type II, Class B aggregate base. The aggregate base materials shall be approved by the Geotechnical Engineer prior to incorporation into the pavement structure. Native soils and fill in roadway areas should be scarified to a depth of 1 foot and recomacted as subgrade. Subgrade material shall be compacted to at least 90 percent, except the top 6 inches which shall be compacted to 95 percent.
- 10.4 For all private car parking areas we recommend a pavement section consisting of 3 inches of asphalt underlain by 4 inches of Type 2 aggregate base.
- 10.5 It is important that parking area grades be set to prevent ponding of water and to provide positive drainage to suitable drainage structures. A desirable slope for drainage in paved areas is two percent; however, a minimum of one percent is allowable.

11.0 SEISMIC DESIGN

- 11.1 Design of structures should include an allowance for earthquake loading. Structures should be designed in conjunction with UBC Zone III seismic design criteria.

APPENDIX B
ASPHALTIC CONCRETE DESIGN

Printout of MS-1/MS-17 Results

Datafile : COMSTOCK UNITS 4 - 11

***** TRAFFIC INFORMATION *****

ANALYSIS PERIOD (years) = 20
 INITIAL DESIGN LIFE (years) = 20
 DESIGN LANE FACTOR = 0.50

INITIAL AVERAGE ANNUAL DAILY TRAFFIC (AADT) = 1560
 % OF AADT THAT IS TRUCKS = 4
 ANNUAL COMPOUND GROWTH RATE (percent) = 4

Type of Usage is RURAL :

TRUCK CLASSIFICATION	Percent of TRUCKS	Truck Factor
TRUCK(2-AXLE, 4-TIRE)	47.0	0.03
TRUCK(2-AXLE, 6-TIRE)	10.0	0.20
TRUCK(3-AXLE or MORE)	2.0	0.67
MULT. TRUCK(3-AXLE)	1.0	0.48
MULT. TRUCK(4-AXLE)	4.0	0.70
MULT. TRUCK(>=5-AXLE)	36.0	0.95

>>>>>> CALCULATED EQUIVALENT AXLE LOADS OF TRAFFIC :

INITIAL YEAR (EAL) = 4,809
 DESIGN LIFE (EAL) = 143,210
 REMAINING 0 years (EAL) = 0
 TOTAL PERIOD (EAL) = 143,210

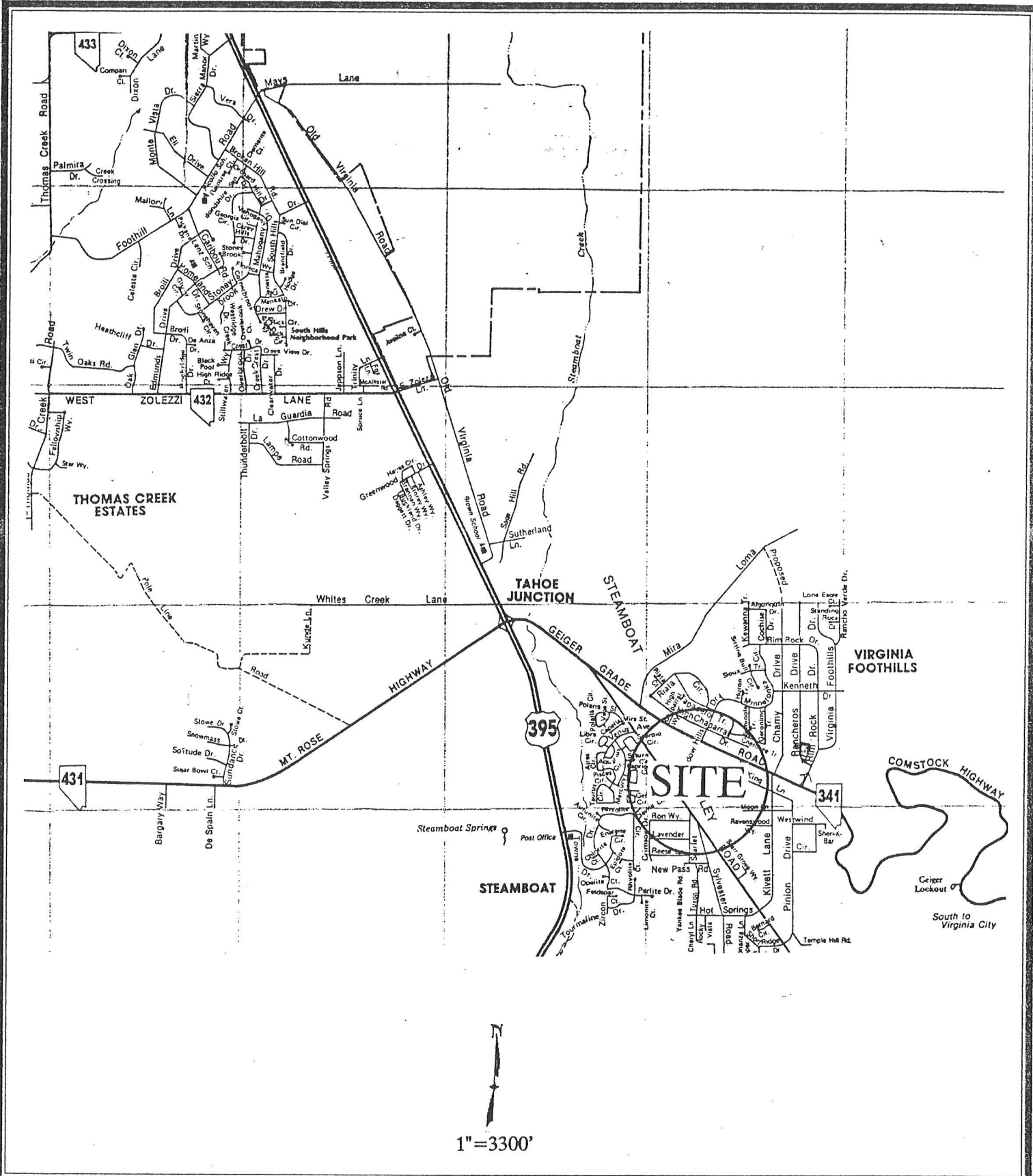

VICINITY MAP
COMSTOCK ESTATES
UNITS 4-11

PLATE 1
Job: 21545
By: LAH Appr: JKG
7:55 AM * 30-JAN-1995

SUMMIT ENGINEERING CORPORATION
CONSULTING ENGINEERS AND SURVEYORS
5405 MAE ANNE AVENUE
RENO, NEVADA (702)-747-8550

P:\DWG\J21545\VIC.DWG

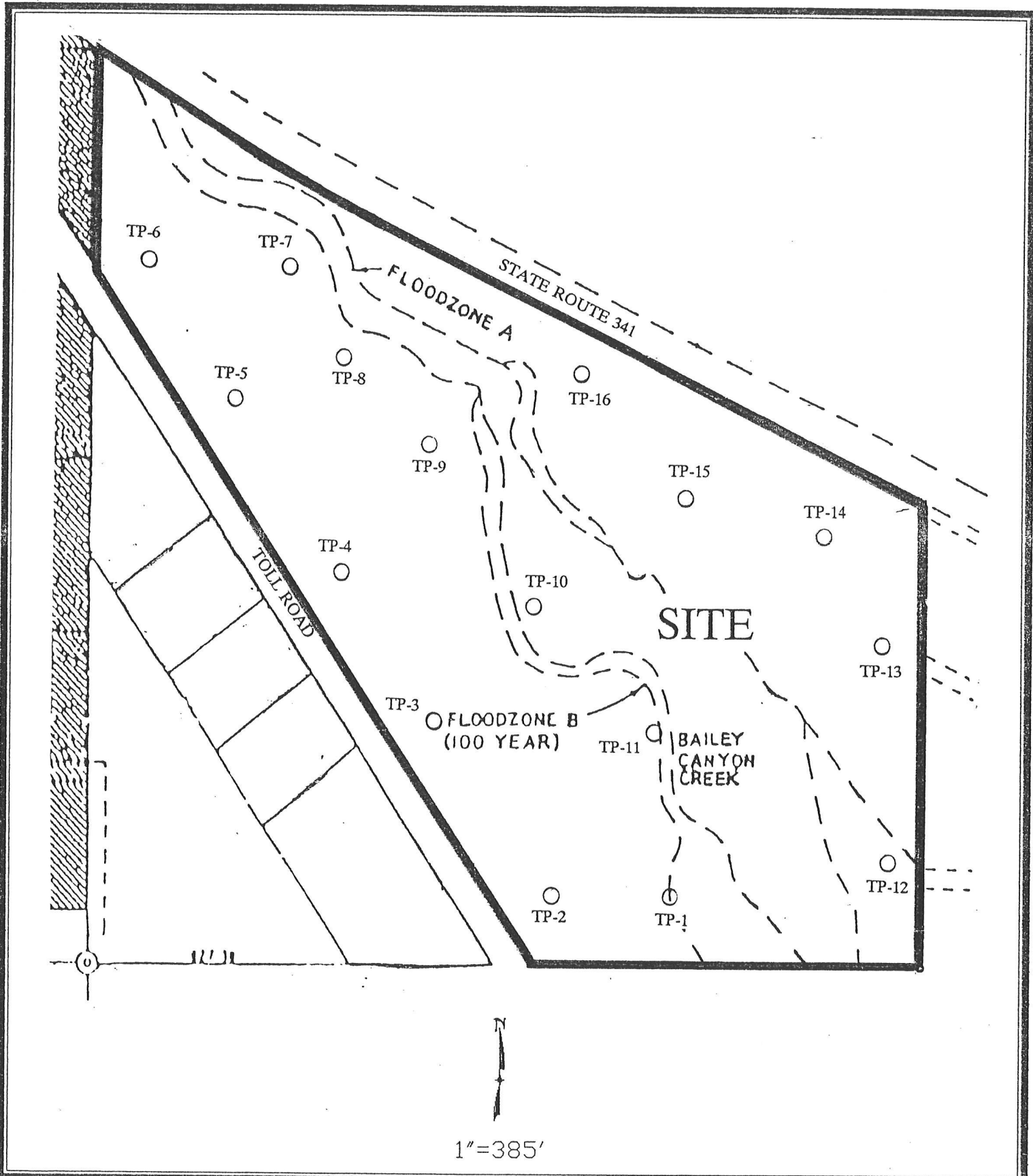

SITE MAP
 COMSTOCK ESTATES
 UNITS 4-11

PLATE 2
 Job: 21545
 By: LAH Appr: JKG
 8:03 AM * 30-JAN-1995

SUMMIT ENGINEERING CORPORATION
 CONSULTING ENGINEERS AND SURVEYORS
 5405 MAE ANNE AVENUE
 RENO, NEVADA (702)-747-8590

P:\DWGS\J21545\SITE.DWG

PLASTICITY INDEX	% PASSING #200	MOISTURE CONTENT % OF DRY WT.	DRY DENSITY (PCF)	DEPTH (FT.)	SAMPLE LOCATION	BLOWS / FOOT	
------------------	----------------	-------------------------------	-------------------	-------------	-----------------	--------------	--

LOG OF Test Pit 1

EQUIPMENT: CAT 215

DATE: 1-19-95 ELEV.

				2			
				4			
				6			
				8			
				10			
				12			
				14			

GW
 Dark Brown Sandy Boulder to Cobble Gravel (GW), rounded boulders up to 16 inches, slightly moist to moist, medium dense to dense.

 Reddish Brown, minor silt.

 Dense to very dense, moderately cemented.

 Bottom of hole at 10 feet.
 No ground water encountered.



SUMMIT ENGINEERING CORPORATION
 FILE NO: 21545 DRAWN BY: CRB
 DATE: 1-25-95 CHKD. BY: JKG

COMSTOCK ESTATES
 UNITS 4 - 11

PLATE
 3

LOG OF Test Pit 3

EQUIPMENT: CAT 215

DATE: 1-19-95 ELEV. _____

PLASTICITY INDEX	% PASSING #200	MOISTURE CONTENT % OF DRY WT.	DRY DENSITY (PCF)	DEPTH (FT.)	SAMPLE LOCATION	BLOWS / FOOT	
					X		SC
				2			Reddish to Dark Brown Sandy Clay (SC), moderately plastic, slightly moist, loose to medium dense.
				4			
				6			
				8	X		GW
	3.0	5.7					Dark Brown Sandy Boulder to Cobble Gravel (GW), minor clay, moist, medium dense to dense.
							Light Brown, slightly cemented, dry to slightly moist, dense.
				10			Bottom of hole at 9.5 feet. No ground water encountered.
				12			
				14			



SUMMIT ENGINEERING CORPORATION
 FILE NO: 21545 DRAWN BY: CRB
 DATE: 1-25-95 CHKD. BY: JKG

COMSTOCK ESTATES
 UNITS 4 - 11

PLATE
 5

							LOG OF Test Pit 4	
							EQUIPMENT: CAT 215	
							DATE: 1-19-95 ELEV.	
PLASTICITY INDEX	% PASSING #200	MOISTURE CONTENT % OF DRY WT.	DRY DENSITY (PCF)	DEPTH (FT.)	SAMPLE LOCATION	BLOWS / FOOT		
24	40.5	24.3		2	X		SC	Reddish Brown Clayey Sand (SC), moderately plastic, moist, loose to medium dense.
				4			GW	Light Brown Sandy Cobble to Boulder Gravel (GW), angular to subangular boulders up to 12 inches, slightly moist, dense.
				6				
				8	X			
				10				Bottom of hole at 10 feet. No ground water encountered.
				12				
				14				

 SUMMIT ENGINEERING CORPORATION	COMSTOCK ESTATES	PLATE 6
	FILE NO: 21545 DRAWN BY: CRB DATE: 1-25-95 CHKD. BY: JKG	

PLASTICITY INDEX	% PASSING #200	MOISTURE CONTENT % OF DRY WT.	DRY DENSITY (PCF)	DEPTH (FT.)	SAMPLE LOCATION	BLOWS / FOOT	
							LOG OF Test Pit 5
							EQUIPMENT: CAT 215
							DATE: 1-19-95 ELEV.

				2	X		SC	Reddish Brown Clayey Sand (SC), moderately plastic, minor cobbles, moist, medium dense.
				4			GW	Dark Brown to Reddish Sandy Boulder to Cobble Gravel (GW), slightly cemented, slightly moist, medium dense to dense.
				6				
				8				Slightly more sand.
				10	X			Dry. Bottom of hole at 10.5 feet. No ground water encountered.
				12				
				14				

	SUMMIT ENGINEERING CORPORATION	COMSTOCK ESTATES UNITS 4 - 11	PLATE 7
FILE NO: 21545 DATE: 1-25-95	DRAWN BY: CRB CHKD. BY: JKG		

							LOG OF Test Pit 6	
							EQUIPMENT: CAT 215	
							DATE: 1-19-95 ELEV.	
PLASTICITY INDEX	% PASSING #200	MOISTURE CONTENT % OF DRY WT.	DRY DENSITY (PCF)	DEPTH (FT.)	SAMPLE LOCATION	BLOWS / FOOT		
							SC	Reddish Brown Clayey Sand (SC), minor cobbles, moist, loose to medium dense.
				2			GW	Reddish Brown to Brown Sandy Boulder to Cobble Gravel (GW), moderately cemented, subrounded boulders up to 12 inches in size, slightly moist, dense.
				4				
				6	X			
				8				Less cemented.
				10				Bottom of hole at 9.5 feet. No ground water encountered.
				12				
				14				

 SUMMIT ENGINEERING CORPORATION FILE NO: 21545 DRAWN BY: CRB DATE: 1-25-95 CHKD. BY: JKG	COMSTOCK ESTATES	PLATE
	UNITS 4 - 11	8

LOG OF Test Pit 7

EQUIPMENT: CAT 215

DATE: 1-19-95 ELEV.

PLASTICITY INDEX	% PASSING #200	MOISTURE CONTENT % OF DRY WT.	DRY DENSITY (PCF)	DEPTH (FT.)	SAMPLE LOCATION	BLOWS / FOOT	
				2			CL Dark Brown Sandy Clay (CL), moist, soft.
				4			GW Reddish Brown Cobble to Boulder Gravel (GW), subrounded boulders up to 12 inches in size, slightly moist, medium dense.
				6			Light brown.
				8			
				10	X		Dark brown, minor silt, slightly moist.
				12			
				14			Bottom of hole at 10.5 feet. No ground water encountered.

 SUMMIT ENGINEERING CORPORATION FILE NO: 21545 DRAWN BY: CRB DATE: 1-25-95 CHKD. BY: JKG	COMSTOCK ESTATES	PLATE 9
	UNITS 4 - 11	

LOG OF Test Pit 8

EQUIPMENT: CAT 215

DATE: 1-19-95 ELEV.

PLASTICITY INDEX	% PASSING #200	MOISTURE CONTENT % OF DRY WT.	DRY DENSITY (PCF)	DEPTH (FT.)	SAMPLE LOCATION	BLOWS / FOOT	
					X		SP
				2			SC
				4			GW
				6			
				8			
				10	X		
	8.0	8.6					
				12			
				14			

Dark Brown: Fine Grained Sand (SP), organics throughout, slightly moist, loose.

Reddish Brown Clayey Sand (SC), moist, loose to medium dense.

Light Brown Sandy Cobble to Boulder Gravel (GW), subangular to angular boulders up to 18 inches in size, slightly moist to dry, dense.

Bottom of hole at 11 feet. No ground water encountered.

 SUMMIT ENGINEERING CORPORATION FILE NO: 21545 DATE: 1-25-95	DRAWN BY: CRB CHKD. BY: JKG	COMSTOCK ESTATES	PLATE
		UNITS 4 - 11	10

LOG OF Test Pit 9

EQUIPMENT: CAT 215

DATE: 1-19-95 ELEV.

PLASTICITY INDEX	% PASSING #200	MOISTURE CONTENT % OF DRY WT.	DRY DENSITY (PCF)	DEPTH (FT.)	SAMPLE LOCATION	BLOWS / FOOT	
	19.0	14.2			X		SM Dark Brown Silty Sand (SM), slightly moist, loose.
				2			GW Reddish Brown to Brown Sandy Cobble to Boulder Gravel (GW), subangular boulders up to 18 inches in size, slightly moist to dry, dense.
				4			
				6			
				8	X		
				10			
				12			
				14			Bottom of hole at 11 feet. No ground water encountered.

 **SUMMIT ENGINEERING CORPORATION**
FILE NO: 21545 DRAWN BY: CRB
DATE: 1-25-95 CHKD. BY: JKG

COMSTOCK ESTATES
UNITS 4 - 11

PLATE
11

LOG OF Test Pit 10

EQUIPMENT: CAT 215

DATE: 1-19-95 ELEV.

PLASTICITY INDEX	% PASSING #200	MOISTURE CONTENT % OF DRY WT.	DRY DENSITY (PCF)	DEPTH (FT.)	SAMPLE LOCATION	BLOWS / FOOT	
				2			GW Dark Brown Sandy Cobble to Boulder Gravel (GW), subangular to subrounded boulders up to 18 inches in size, slightly moist to moist, medium dense. Bottom of hole at 10 feet. No ground water encountered.
				4	X		
	3.8	7.3		6			
				8			
				10			
				12			
				14			



SUMMIT ENGINEERING CORPORATION

FILE NO: 21545 DRAWN BY: CRB
DATE: 1-25-95 CHKD. BY: JKG

COMSTOCK ESTATES
UNITS 4 - 11

PLATE
12

LOG OF Test Pit 11

EQUIPMENT: CAT 215

DATE: 1-19-95 ELEV.

PLASTICITY INDEX	% PASSING #200	MOISTURE CONTENT % OF DRY WT.	DRY DENSITY (PCF)	DEPTH (FT.)	SAMPLE LOCATION	BLOWS / FOOT	
				2			<p>GW Dark Brown Sandy Cobble to Boulder Gravel (GW), subangular boulders up to 18 inches in size, moist, dense.</p> <p>Moderately cemented.</p> <p>Bottom of hole at 9 feet. No ground water encountered.</p>
				4			
				6			
				8	X		
				10			
				12			
				14			

 **SUMMIT** ENGINEERING CORPORATION
FILE NO: 21545 DRAWN BY: CRB
DATE: 1-25-95 CHKD. BY: JKG

COMSTOCK ESTATES
UNITS 4 - 11

PLATE
13

PLASTICITY INDEX	% PASSING #200	MOISTURE CONTENT % OF DRY WT.	DRY DENSITY (PCF)	DEPTH (FT.)	SAMPLE LOCATION	BLOWS / FOOT	
							LOG OF Test Pit 12
							EQUIPMENT: CAT 215
							DATE: 1-19-95 ELEV.
				2			GW Dark Brown Sandy Cobble to Boulder Gravel (GW), subangular boulders up to 18 inches in size, slightly moist, dense. Slightly moist to dry. Bottom of hole at 9 feet. No ground water encountered.
				4			
				6	X		
				8			
				10			
				12			
				14			

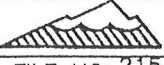
 SUMMIT ENGINEERING CORPORATION FILE NO: 21545 DRAWN BY: CRB DATE: 1-25-95 CHKD. BY: JKG	COMSTOCK ESTATES UNITS 4 - 11	PLATE 14
--	---	--------------------

LOG OF Test Pit 13

EQUIPMENT: CAT 215

DATE: 1-19-95 ELEV.

PLASTICITY INDEX	% PASSING #200	MOISTURE CONTENT % OF DRY WT.	DRY DENSITY (PCF)	DEPTH (FT.)	SAMPLE LOCATION	BLOWS / FOOT	
18	32.3	21.8		2	X		SC Reddish Brown Clayey Sand (SC), moist, medium dense.
				4			GW Light Reddish Brown Sandy Boulder to Cobble Gravel (GW), slightly cemented, subangular boulders up to 18 inches in size, dry to slightly moist, dense. No cementing.
				6			
				8			
				10	X		Bottom of hole at 10 feet. No ground water encountered.
				12			
				14			

 **SUMMIT** ENGINEERING CORPORATION
FILE NO: 21545 DRAWN BY: CRB
DATE: 1-25-95 CHKD. BY: JKG

COMSTOCK ESTATES
UNITS 4 - 11

PLATE
15

PLASTICITY INDEX	% PASSING #200	MOISTURE CONTENT % OF DRY WT.	DRY DENSITY (PCF)	DEPTH (FT.)	SAMPLE LOCATION	BLOWS / FOOT
------------------	----------------	-------------------------------	-------------------	-------------	-----------------	--------------

LOG OF Test Pit 14

EQUIPMENT: CAT 215

DATE: 1-19-95 ELEV.

							GW	Reddish Brown Sandy Cobble to Boulder Gravel (GW), subangular boulders up to 18 inches in size, slightly moist, dense.
				2				
				4				
				6	X			Dry.
				8				Bottom of hole at 8 feet. No ground water encountered.
				10				
				12				
				14				



SUMMIT ENGINEERING CORPORATION
 FILE NO: 21545 DRAWN BY: CRB
 DATE: 1-25-95 CHKD. BY: JKG

COMSTOCK ESTATES
 UNITS 4 - 11

PLATE
 16

LOG OF Test Pit 15

EQUIPMENT: CAT 215

DATE: 1-19-95 ELEV.

PLASTICITY INDEX	% PASSING #200	MOISTURE CONTENT % OF DRY WT.	DRY DENSITY (PCF)	DEPTH (FT.)	SAMPLE LOCATION	BLOWS / FOOT	
				2	X		SW Reddish Brown Gravelly Sand (SW), coarse grained, minor silt, slightly moist, loose to medium dense.
				4			GW Reddish Brown Sandy Cobble to Boulder Gravel (GW), slightly cemented, subrounded boulders up to 12 inches in size, slightly moist, dense.
				6			
				8			
				10			Bottom of hole at 10 feet. No ground water encountered.
				12			
				14			

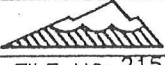
 **SUMMIT** ENGINEERING CORPORATION
FILE NO: 21545 DRAWN BY: CRB
DATE: 1-25-95 CHKD. BY: JKG

COMSTOCK ESTATES
UNITS 4 - 11

PLATE
17

LOG OF Test Pit 16

EQUIPMENT: CAT 215

DATE: 1-19-95 ELEV.

PLASTICITY INDEX	% PASSING #200	MOISTURE CONTENT % OF DRY WT.	DRY DENSITY (PCF)	DEPTH (FT.)	SAMPLE LOCATION	BLOWS / FOOT	
					X		SW Dark Brown Sand (SW), minor gravel, fine grained, minor silt, moist, loose.
				2			GW Light Brown Sandy Cobble to Boulder Gravel (GW), subrounded boulders up to 12 inches in size, slightly moist to dry, dense.
				4			
				6			
				8	X		
				10			
				12			
				14			
							Bottom of hole at 10.5 feet. No ground water encountered.

 SUMMIT ENGINEERING CORPORATION	COMSTOCK ESTATES	PLATE
	UNITS 4 - 11	18
FILE NO: 21545 DATE: 1-25-95	DRAWN BY: CRB CHKD. BY: JKG	

		MAJOR DIVISIONS	GRAPHIC SYMBOL	GROUP SYMBOL	TYPICAL NAMES		
COARSE GRAINED SOILS LESS THAN 50% PASSING No. 200 SIEVE	GRAVELS LESS THAN 50% COARSE FRACTION PASSES THE No.4 SIEVE	CLEAN GRAVELS WITH LITTLE OR NO FINES		GW	WELL GRADED GRAVELS, GRAVEL/SAND MIXTURE		
		GRAVELS WITH OVER 12% FINES		GP	POORLY GRADED GRAVELS, GRAVEL/SAND MIXTURE		
				GM	SILTY GRAVEL, POORLY GRADED GRAVEL/SAND/SILT MIXTURE		
			GC	CLAYEY GRAVEL, POORLY GRADED GRAVEL/SAND/CLAY MIXTURE			
	SANDS MORE THAN 50% COARSE FRACTION PASSES THE No.4 SIEVE	CLEAN SANDS WITH LITTLE OR NO FINES		SW	WELL GRADED SANDS, GRAVELLY SANDS		
				SP	POORLY GRADED SANDS, GRAVELLY SANDS		
		SANDS WITH OVER 12% FINES		SM	SILTY SANDS, POORLY GRADED SAND/CLAY MIXTURES		
				SC	CLAYEY SAND, POORLY GRADED SAND/CLAY MIXTURES		
			FINE GRAINED SOILS MORE THAN 50% PASSING No. 200 SIEVE	SILTS AND CLAYS LIQUID LIMIT LESS THAN 50		ML	INORGANIC SILTS & VERY FINE SANDS OF LOW PLASTICITY
						CL	INORGANIC CLAYS OF LOW TO MEDIUM PLASTICITY, LEAN CLAYS
	OL	ORGANIC CLAYS AND ORGANIC SILTY CLAYS OF LOW PLASTICITY					
SILTS AND CLAYS LIQUID LIMIT GREATER THAN 50		MH	INORGANIC SILTS, MICACEOUS OR DIATOMACEOUS FINE SANDY OR SILTY SOILS				
		CH	INORGANIC CLAYS OF HIGH PLASTICITY, FAT CLAYS				
		OH	ORGANIC CLAYS OF MEDIUM TO HIGH PLASTICITY, ORGANIC SILTS				
		PT	TOPSOIL, PEAT, ORGANIC RICH SOILS				
ORGANIC RICH SOILS							
OTHER SOILS				F	FILL MATERIALS		

UNIFIED SOIL CLASSIFICATION SYSTEM



UNDISTURBED
SAMPLE



BULK SAMPLE



NO RECOVERY



MEASURED DEPTH
TO GROUNDWATER

COMSTOCK ESTATES
UNITS 4 - 11
WASHOE COUNTY

JOB NO: 21545
APPR: JKG BY: CRB
PLATE 19
7:42 AM * 30-JAN-1995

SUMMIT

CONSULTING ENGINEERS AND SURVEYORS

5405 MAE ANNE AVENUE
RENO, NEVADA (702)-747-8550

P:\DWGS\J21545\KEY.DWG

UNIFIED SOIL CLASSIFICATION SYSTEM

GRAVEL	COARSE SAND	MEDIUM SAND	FINE SAND	SILT AND CLAY
--------	-------------	-------------	-----------	---------------

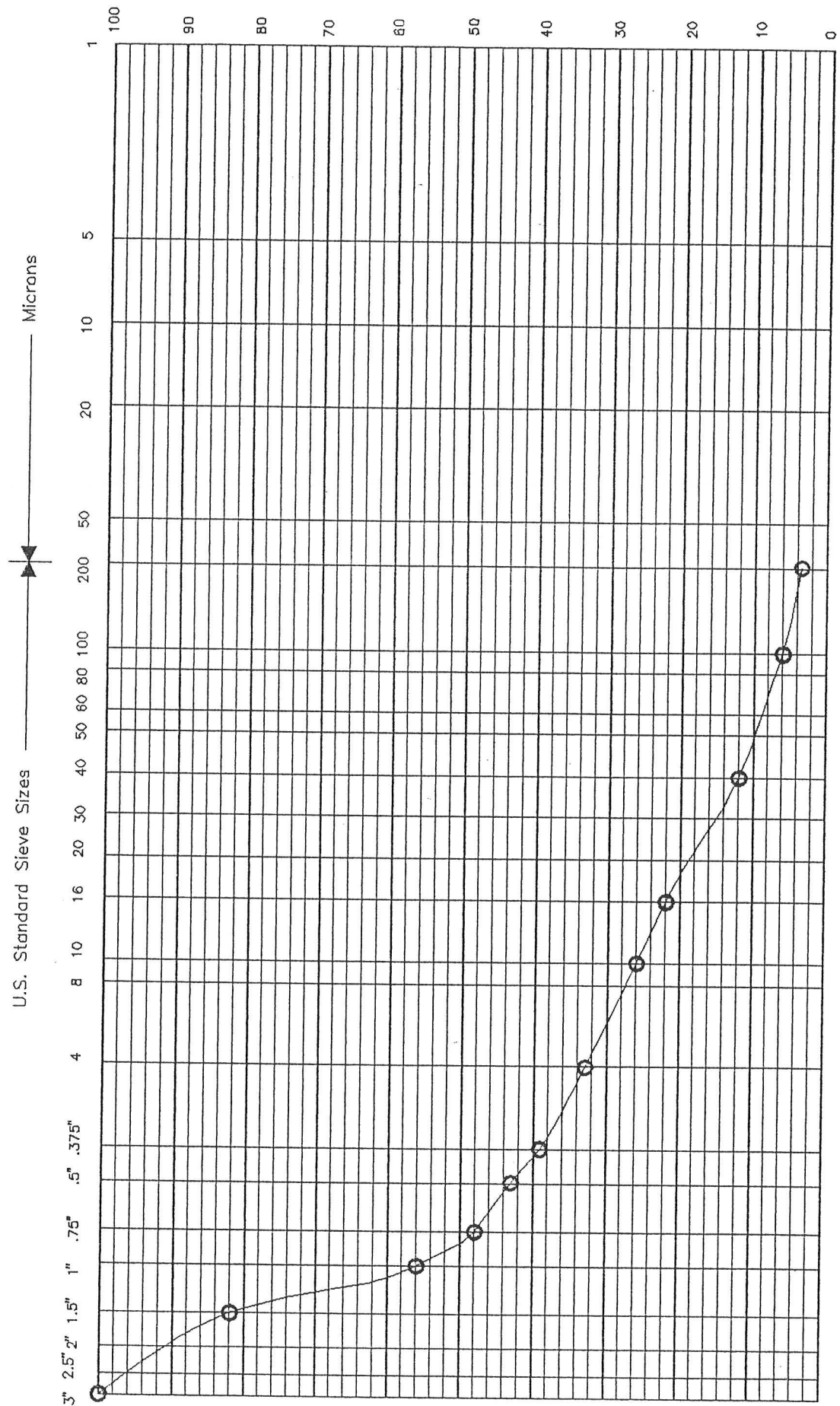

GROUP SYMBOL	UNIFIED SOIL CLASSIFICATION FINE GRAINED SOIL GROUPS
OL	ORGANIC SILTS AND ORGANIC SILTY CLAYS OF LOW PLASTICITY
ML	INORGANIC CLAYEY SILTS TO VERY FINE SANDS OF LOW PLASTICITY
CL	INORGANIC CLAYS OF LOW TO MEDIUM PLASTICITY
OH	ORGANIC CLAYS AND SILTS OF HIGH PLASTICITY
MH	INORGANIC SILTS OF HIGH PLASTICITY
CH	ORGANIC CLAYS OF HIGH PLASTICITY

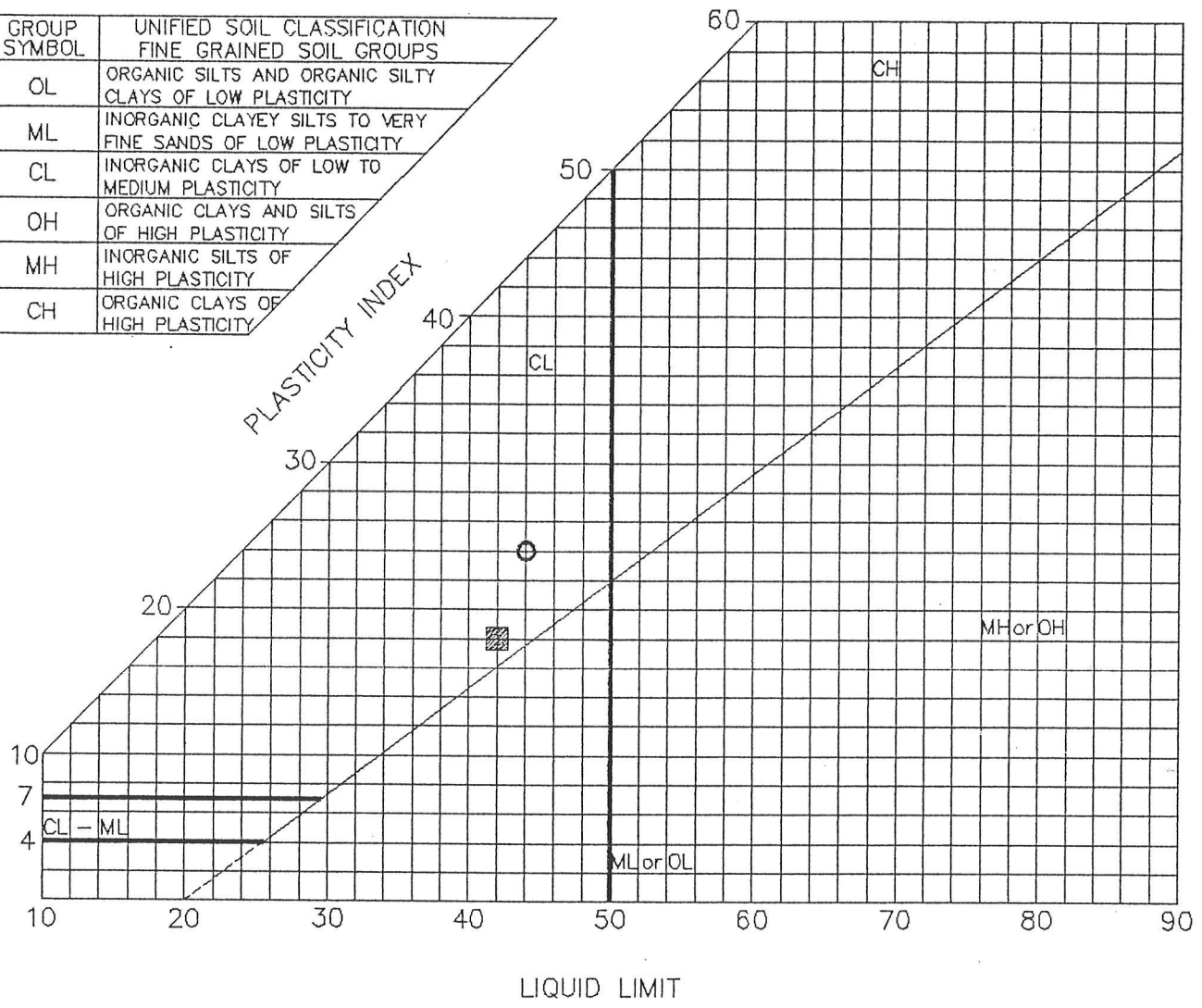

TEST SYMBOL	BORING NUMBER	SAMPLE NUMBER	% PASSING #200 SIEVE	LIQUID LIMIT	PLASTICITY INDEX	CLASSIFICATION
○	TP-4	0.5-1.5'	40.5	44	24	SC
■	TP-13	0.5-1.5'	32	42	18	SC

PLASTICITY INDEX
COMSTOCK ESTATES
UNITS 4-11, NEVADA

JOB NO: 21545
APPR: JKG BY: CRB
PLATE 22
7:29 AM * 30-JAN-1995

SUMMIT
CONSULTING ENGINEERS AND SURVEYORS
5405 MAE ANNE AVENUE
RENO, NEVADA (702)-747-8550

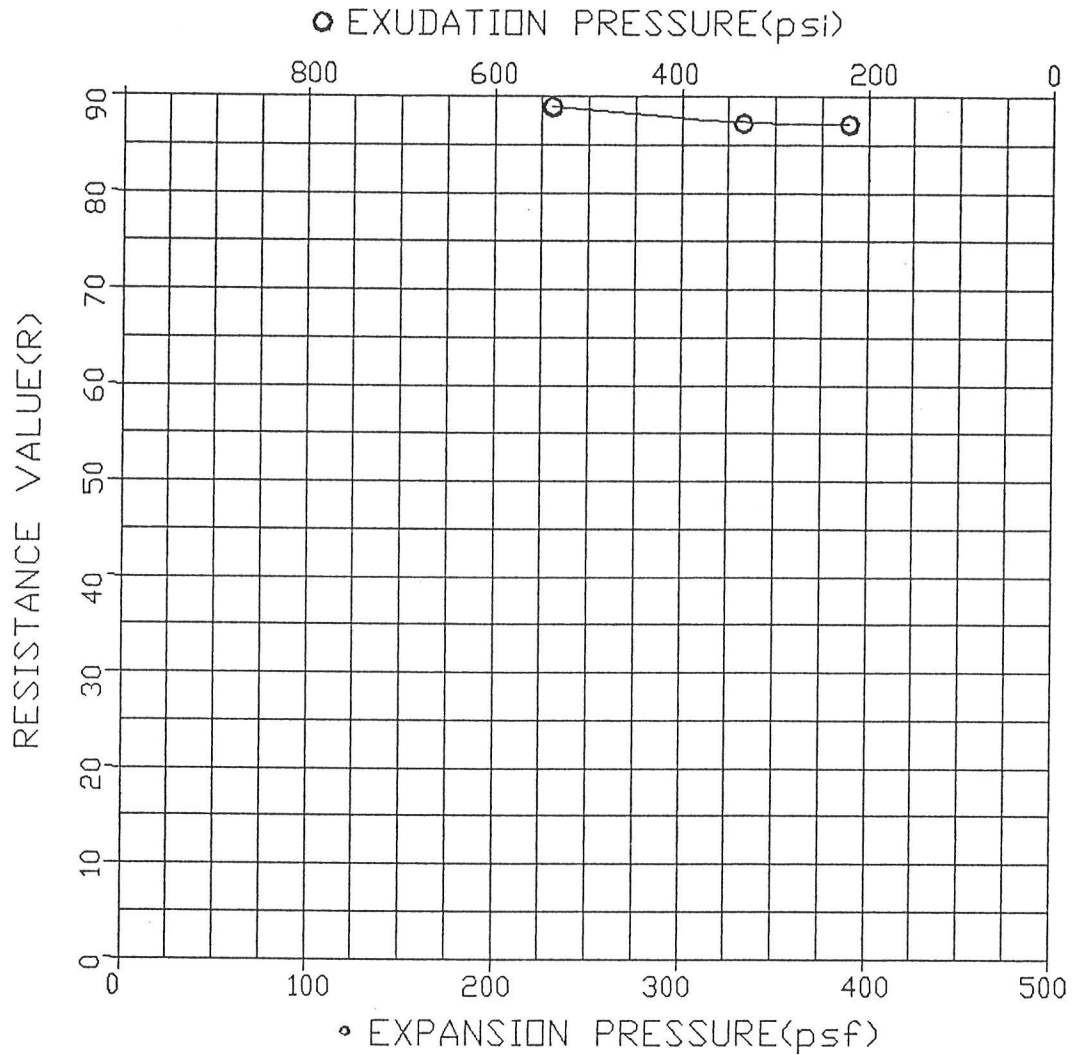

Specimen No.	A	B	C
Water Content(%)	13.3	11.7	12.5
Dry Density(pcf)	118.3	112.8	120.8
Exudation Pressure(psi)	207	541	334
Expansion Pressure(psf)	-	-	-
Resistance Value(R)	87	89	87

Sample Source	Classification	Sand Equivalent	Values Interpolated at 300 psi Exudation press.	
			Expansion Pressure	R-value
TP-1 2-3 FEET	BROWN SANDY GRAVEL (GW)	----	-	87

 **SUMMIT** ENGINEERING CORPORATION
 FILE NO: 21545 DRAWN BY: LAH
 DATE: 1-30-95 CHKD. BY: JKG

COMSTOCK ESTATES
 UNITS 4 - 11

PLATE
 23

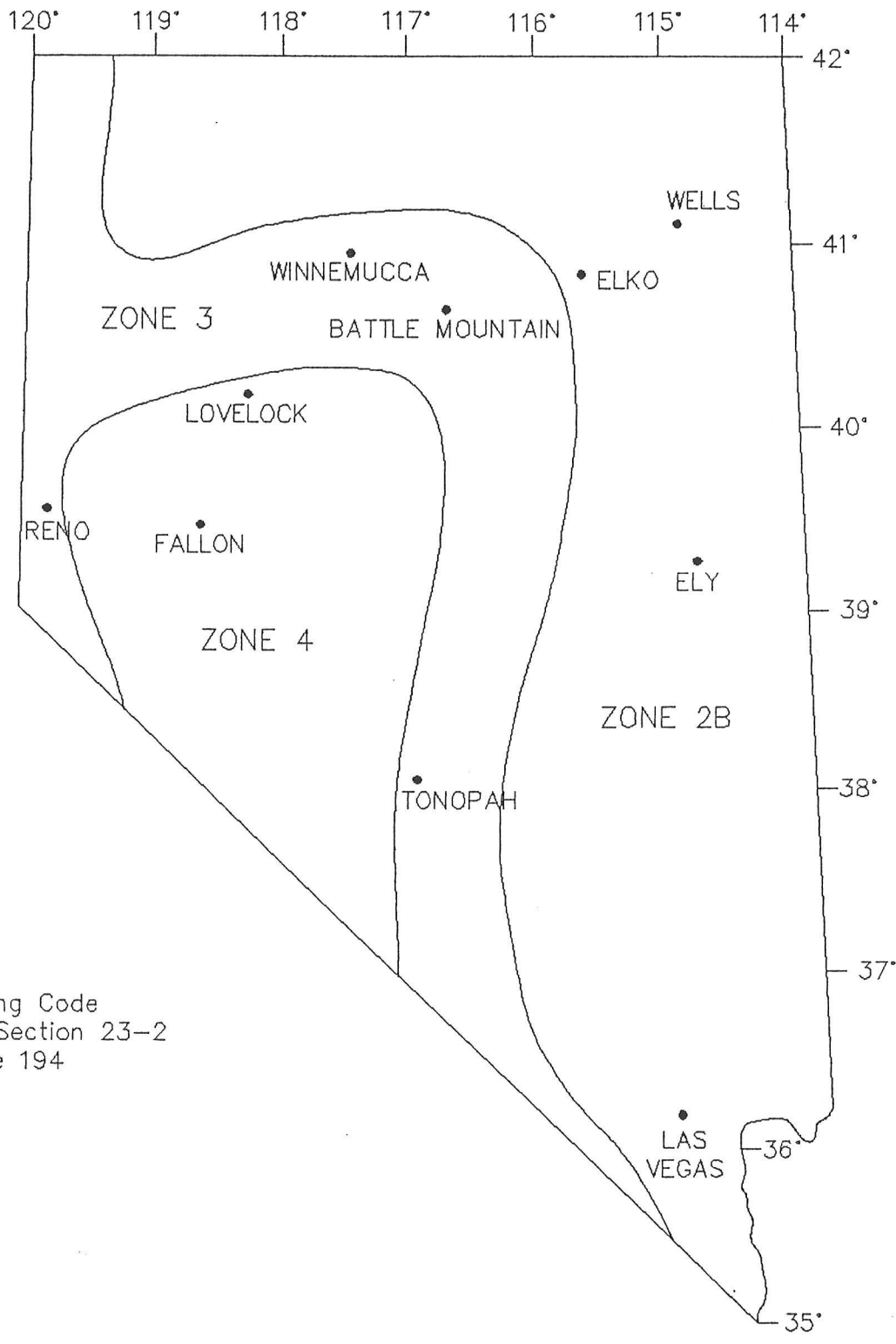

Reference

Uniform Building Code
 1991 Edition, Section 23-2
 Figure 2, Page 194

SEISMIC ZONE MAP
 COMSTOCK UNITS 4-11
 WASHOE COUNTY

JOB NO. 21545
 APPR.: JKG BY: CRB
 PLATE 24
 7:38 AM * 30-JAN-1995

SUMMIT
 CONSULTING ENGINEERS AND SURVEYORS
 5405 MAE ANNE AVENUE
 RENO, NEVADA (702)-747-8550

P:\DWGS\J21545\SEISMIC.DWG

PRELIMINARY DRAINAGE REPORT
FOR
BAILEY CREEK ESTATES TENTATIVE MAP

Prepared for:

STL Company, Inc
16500 Wedge Parkway, Bldg A Suite 2
Reno, NV 89511

December 15, 2016

Prepared by:

Wood Rodgers, Inc.
1361 Corporate Blvd.
Reno, NV 89502
(775) 823-4068
Steven Strickland, P.E. - Principal

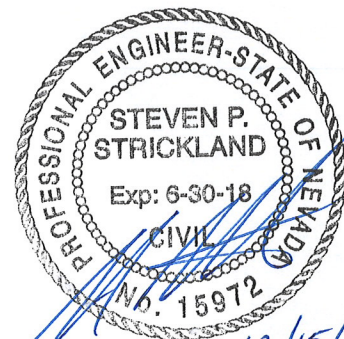

WOOD RODGERS
DEVELOPING INNOVATIVE DESIGN SOLUTIONS

WTM16-003 - EXHIBIT E

TABLE OF CONTENTS

1	Introduction	1
1.1	Project Location/Historic Drainage.....	1
1.2	Background/Previous Studies.....	1
1.3	Regulatory Perspective	2
2	Preliminary Design	2
3	Hydrologic Analysis	2
4	Conclusions	3
5	References	3

APPENDIX

VICINITY MAP

FEMA FIRM Flood Zone Exhibit

PRELIMINARY BASIN FLOW CALCULATIONS (5-YEAR)

PRELIMINARY BASIN FLOW CALCULATIONS (100-YEAR)

PRELIMINARY STORM DRAIN SYSTEM LAYOUT AND HYDROLOGIC BASIN MAP



1 INTRODUCTION

This report shall serve as the preliminary drainage report for the Bailey Creek Estates Tentative Map, which will consist of 56 single family lots. The purpose of this report is to address the drainage issues that result from development of the proposed project site in accordance with Truckee Meadows Regional Drainage Manual (TMRDM) and Washoe County development standards. As this report is preliminary in nature, a more detailed study will need to be conducted and a final technical drainage report will need to be submitted with the final improvement plans for the project.

1.1 PROJECT LOCATION/HISTORIC DRAINAGE

The proposed project site (APNs 017-520-03 and 017-480-02) is approximately 28.7± acres in size and is located within Section 34 of T18N, R20E, MDM, Washoe County, Nevada.

The project site is bounded by Geiger Grade to the north, Cottonwood Creek Estates and Comstock Estates to the south, and Medium Density Suburban (MDS) lots to the east. A Vicinity Map is included in the **Appendix** of this report for reference.

The parcel is currently unimproved open land. Bailey Creek runs adjacent to the southern boundary of the property. The creek flows on adjacent common area from southeast to northwest. Offsite stormwater from the MDS parcels to the east flow onto the project site and generally run parallel to and into Bailey Creek. The majority of the proposed project site will be mass graded and will be improved/disturbed.

The project site is located in FEMA Zone X, areas outside the determined to be outside the 500-year annual chance floodplain, and Shaded Zone X, areas of 0.2% annual chance of flood; areas of 1% annual chance of flood with depths less than 1 foot or with drainage areas of less than one square mile. The site can be located on FEMA FIRM Panel 3263G. An exhibit identifying the FEMA zone boundaries and the project site is included in the **Appendix**.

1.2 BACKGROUND/PREVIOUS STUDIES

Bailey Creek Estates was originally part of the Cottonwood Estates Tentative Map. Cottonwood Estates was developed on the southwest side of Bailey Creek and a portion of the Bailey Creek Estates project site had recorded lots and approved improvement plans. The Cottonwood Creek Tentative Map has since expired and the previously recorded lots were reverted back to acreage.



A LOMR on Bailey Creek was completed on Bailey Creek in 2001 and the base flood elevations were established along the Bailey Creek. The project boundaries are outside of the current FEMA AE zone on the creek, but is anticipated that the final drainage analysis would include an updated review of the flood limits based upon current topographic information.

1.3 REGULATORY PERSPECTIVE

The Project site is located within the Washoe County jurisdiction. The onsite pipes and drain inlet drainage facilities will be operated and maintained by Washoe County. The Baily Creek Estates HOA will be responsible for maintenance of the detention basins and Bailey Creek.

2 PRELIMINARY DESIGN

The proposed drainage system for the project site consists of sheet flow from the lots and streets into gutters with which storm water is conveyed into drop inlets and underground storm drain pipes. Onsite flows will be directed to detention basins or directly to Bailey Creek. We have estimated five outfalls from the project into Bailey Creek. Two of those outfalls will be directed to detention basins to mitigate for flow rate increases due to development. Offsite flows from the MDS parcels to the east will be picked up in v-ditches located on the project's east boundary. The ditches will pick up the sheet flow from the east and convey it to the underground storm drain system. One detention basin is proposed in the common area with in the project boundary and one detention basin is proposed in the adjacent common area along Bailey Creek.

3 HYDROLOGIC ANALYSIS

Preliminary flows were estimated for the 5-year and 100-year design events using the rational method per the Truckee Meadows Drainage Manual. NOAA Atlas 14 was used for rainfall intensities. The basin calculations are included in the Appendix. There are five outfalls that will drain onsite and offsite flows into Bailey Creek. Q5's ranged from 0.8 cfs to 25.0 cfs, and Q100's ranged from 2.7 cfs to 75.6 cfs. These flow rates are manageable in storm drain pipes within the street Right of Way. Excluding flows coming down Bailey Creek the predevelopment flows coming through the project site have been estimated at 23.3 cfs for the Q5 and 75.5 cfs for the Q100. Total post development flows, prior to detention, have been estimated to be 40.5 cfs for the Q5 and 127.1 cfs for the Q100. These are cumulative rational method summaries and are therefore conservative. It's likely the flows will be slightly smaller when routed through the drainage system in greater detail with a final design analysis. The detention basins will be sized to reduce the total post development flows to the maximum of the total predevelopment flow prior to the storm drainage leaving the site.



4 CONCLUSIONS

The drainage facilities for the Bailey Creek Estates subdivision will be designed to capture and perpetuate the design storm event flows to an underground storm drain system and detention basins. The conveyance of flows is in conformance with the Washoe County Development Code and the TMRDM. There will be no negative impacts to any adjacent or downstream properties as a result of development during the 5-year and 100-year storms due to the implementation of the proposed storm water management system. As previously stated, this report is preliminary in nature and a more detailed study will need to be conducted and a final technical drainage report will need to be submitted with the final improvement plans for the project.

5 REFERENCES

Truckee Meadows Regional Drainage Manual, April 30, 2009.

Washoe County Development Code, Latest Version.



APPENDIX

VICINITY MAP

FEMA FIRM Flood Zone Exhibit

PRELIMINARY BASIN FLOW CALCULATIONS (5-YEAR)

PRELIMINARY BASIN FLOW CALCULATIONS (100-YEAR)

PRELIMINARY STORM DRAIN SYSTEM LAYOUT AND HYDROLOGIC BASIN MAP



 Project Area

Source: Esri, DigitalGlobe, GeoEye, Earthstar Geographics, CNES/Airbus DS, USDA, USGS, AEX, Getmapping, Aerogrid, IGN, IGP, swisstopo, and the GIS User Community

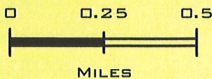





Vicinity Map
 Bailey Creek Estates
 Washoe County
 December, 2016



WOOD RODGERS
 BUILDING RELATIONSHIPS ONE PROJECT AT A TIME
 1361 Corporate Boulevard
 Reno, NV 89502
 Tel: 775.823.4068
 Fax: 775.823.4066



Source: Esri, DigitalGlobe, GeoEye, Earthstar Geographics, CNES/Airbus DS, USDA, USGS, AeroGRID, IGN, and the GIS User Community

	Project Area
FEMA Flood Zone	
	A
	AE
	SHADED ZONE X
	FLOODWAY

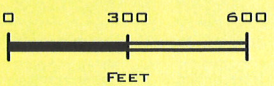

FEMA Flood Zone
 Bailey Creek Estates
 Washoe County
 December, 2016



WOOD RODGERS
 BUILDING RELATIONSHIPS ONE PROJECT AT A TIME
 1361 Corporate Boulevard
 Reno, NV 89502
 Tel: 775.823.4068
 Fax: 775.823.4066

TIME OF CONCENTRATION															5-YEAR STORM EVENT								
Drainage Basin	Drainage Area (AC)	Weighted Average C-Factor _{5-Year}	Initial Flow Time, T _i			Travel Time, T _t								Total (T _i +T _t)	Urbanized Basins Check	Final	NOAA ATLAS 14 Rainfall Intensity	Rational Flow					
			Overland Flow			Channelized Flow				Gutter Flow									T _c (min)	T _c * (min)	T _c (min)	I _{5-year} (in/hour)	Q _{5-year} (cfs)
			L _i (ft)	S (ft/ft)	T _i (min)	L _s (ft)	S (ft/ft)	V (ft/s)	T _{t1} (min)	L _t (ft)	S (ft/ft)	V (ft/s)	T _{t2} (min)										
A-1	1.50	0.41	204	0.0200	14.0	144	0.0200	2.3	1.1					14.0	11.9	11.9	1.22	0.8					
B-1	1.67	0.42	153	0.0200	12.1					346	0.0200	2.9	2.0	14.1	12.8	12.8	1.19	0.8					
C-1	0.33	0.40	90	0.0200	9.5	91	0.0200	2.3	0.7					10.1	11.0	10.1	1.30	0.2					
C-2	1.93	0.50	164	0.0200	11.0					408	0.0200	2.9	2.4	13.4	13.2	13.2	1.17	1.1					
C-3	1.37	0.41	167	0.0200	12.7					267	0.0200	2.9	1.6	14.3	12.4	12.4	1.20	0.7					
C-4	1.71	0.41	173	0.0200	13.0					396	0.0200	2.9	2.3	15.3	13.2	13.2	1.17	0.8					
C-5	1.01	0.50	174	0.0200	11.3					134	0.0200	2.9	0.8	12.1	11.7	11.7	1.23	0.6					
C-6	1.55	0.50	116	0.0200	9.3					301	0.0200	2.9	1.7	11.0	12.3	11.0	1.27	1.0					
C-7	2.37	0.50	142	0.0200	10.2					309	0.0200	2.9	1.8	12.0	12.5	12.0	1.22	1.4					
C-8	1.71	0.40	213	0.0200	14.7					278	0.0200	2.9	1.6	16.3	12.7	12.7	1.19	0.8					
C-9	1.04	0.50	187	0.0200	11.8					236	0.0200	2.9	1.4	13.1	12.4	12.4	1.21	0.6					
C-10	1.14	0.39	178	0.0234	12.8					216	0.0137	2.4	1.5	14.3	12.2	12.2	1.21	0.5					
D-1	1.68	0.49	152	0.0200	10.8					407	0.0200	2.9	2.4	13.1	13.1	13.1	1.17	1.0					
D-2	1.56	0.40	152	0.0137	14.0					194	0.0137	2.4	1.4	15.4	11.9	11.9	1.23	0.8					
D-3	1.23	0.50	84	0.0013	19.7					394	0.0179	2.7	2.4	22.1	12.7	12.7	1.19	0.7					
D-4	1.42	0.45								529	0.0183	2.8	3.2	5.0	12.9	5.0	1.73	1.1					
D-5	0.23	0.41	260	0.0200	16.0	555	0.0200	2.3	4.1					20.0	14.5	14.5	1.11	0.1					
E-1	1.41	0.50								351	0.0188	2.8	2.1	5.0	12.0	5.0	1.73	1.2					
E-2	2.26	0.61	171	0.0234	8.6					392	0.0254	3.2	2.0	10.7	13.1	10.7	1.28	1.8					
E-3	0.16	0.36	36	0.0178	6.6					264	0.0178	2.7	1.6	8.2	11.7	8.2	1.46	0.1					
E-4	0.13	0.35	29	0.0320	5.0					195	0.0320	3.6	0.9	5.9	11.2	5.9	1.66	0.1					
E-5	0.14	0.35	64	0.0492	6.4					193	0.0492	4.5	0.7	7.1	11.4	7.1	1.55	0.1					
E-6	0.18	0.50	118	0.0200	9.3	387	0.0200	2.3	2.8					12.1	12.8	12.1	1.22	0.1					
O-1	0.10	0.35	51	0.0200	7.7	230	0.0200	2.3	1.7					9.4	11.6	9.4	1.36	0.0					
O-2	0.15	0.36								416	0.0179	2.7	2.5	5.0	12.3	5.0	1.73	0.1					
O-3	5.43	0.35	212	0.0400	12.5					610	0.0340	3.7	2.7	15.2	14.6	14.6	1.11	2.1					
O-4	8.58	0.35	324	0.0384	15.6	587	0.0276	2.7	3.6					19.2	15.1	15.1	1.09	3.3					
O-5	6.13	0.35	217	0.0337	13.3	823	0.0202	2.3	6.0					19.3	15.8	15.8	1.07	2.3					
O-6	0.29	0.35	168	0.0576	9.8	80	0.0576	3.9	0.3					10.2	11.4	10.2	1.30	0.1					
O-7	1.26	0.35	305	0.0428	14.6	180	0.0298	2.8	1.1					15.7	12.7	12.7	1.19	0.5					
O-8	1.44	0.35	176	0.0372	11.6	391	0.0310	2.8	2.3					13.9	13.1	13.1	1.17	0.6					
O-9	5.15	0.35	133	0.0235	11.7	499	0.0187	2.2	3.8					15.5	13.5	13.5	1.16	2.1					
O-10	5.60	0.35	238	0.0245	15.5	777	0.0271	2.7	4.9					20.4	15.6	15.6	1.07	2.1					

Drainage Basin	Drainage Area (AC)	Weighted Average C-Factor _{100-Year}	TIME OF CONCENTRATION											100-YEAR STORM EVENT				
			Initial Flow Time, T _i			Travel Time, T _t							Total (T _i +T _t)	Urbanized Basins Check	Final	NOAA ATLAS 14 Rainfall Intensity	Rational Flow	
			Overland Flow			Channelized Flow				Gutter Flow								I _{100-year} (in/hour)
			L _i (ft)	S (ft/ft)	T _i (min)	L _s (ft)	S (ft/ft)	V(ft/s)	T _{t1} (min)	L _t (ft)	S (ft/ft)	V (ft/s)	T _{t2} (min)	T _c (min)	T _c *(min)	T _c (min)		
A-1	1.50	0.56	204	0.0200	11.0	144	0.0200	2.3	1.1					11.0	11.9	11.0	3.14	2.7
B-1	1.67	0.57	153	0.0200	9.4					346	0.0200	2.9	2.0	11.4	12.8	11.4	3.09	2.9
C-1	0.33	0.55	90	0.0200	7.4	91	0.0200	2.3	0.7					8.1	11.0	8.1	3.63	0.7
C-2	1.93	0.65	164	0.0200	8.2					408	0.0200	2.9	2.4	10.6	13.2	10.6	3.18	4.0
C-3	1.37	0.56	167	0.0200	10.0					267	0.0200	2.9	1.6	11.5	12.4	11.5	3.08	2.4
C-4	1.71	0.56	173	0.0200	10.2					396	0.0200	2.9	2.3	12.5	13.2	12.5	2.97	2.8
C-5	1.01	0.65	174	0.0200	8.5					134	0.0200	2.9	0.8	9.3	11.7	9.3	3.40	2.2
C-6	1.55	0.65	116	0.0200	6.9					301	0.0200	2.9	1.7	8.7	12.3	8.7	3.51	3.5
C-7	2.37	0.65	142	0.0200	7.7					309	0.0200	2.9	1.8	9.5	12.5	9.5	3.36	5.2
C-8	1.71	0.55	213	0.0200	11.5					278	0.0200	2.9	1.6	13.2	12.7	12.7	2.94	2.8
C-9	1.04	0.65	187	0.0200	8.8					236	0.0200	2.9	1.4	10.2	12.4	10.2	3.23	2.2
C-10	1.14	0.54	178	0.0234	10.1					216	0.0137	2.4	1.5	11.6	12.2	11.6	3.07	1.9
D-1	1.68	0.64	152	0.0200	8.1					407	0.0200	2.9	2.4	10.5	13.1	10.5	3.19	3.4
D-2	1.56	0.55	152	0.0137	11.0					194	0.0137	2.4	1.4	12.4	11.9	11.9	3.03	2.6
D-3	1.23	0.65	84	0.0013	14.8					394	0.0179	2.7	2.4	17.2	12.7	12.7	2.95	2.4
D-4	1.42	0.60								529	0.0183	2.8	3.2	5.0	12.9	5.0	4.26	3.6
D-5	0.23	0.56	260	0.0200	12.5	555	0.0200	2.3	4.1					16.5	14.5	14.5	2.73	0.3
E-1	1.41	0.65								351	0.0188	2.8	2.1	5.0	12.0	5.0	4.26	3.9
E-2	2.26	0.76	171	0.0234	6.0					392	0.0254	3.2	2.0	8.0	13.1	8.0	3.66	6.3
E-3	0.16	0.51	36	0.0178	5.3					264	0.0178	2.7	1.6	6.9	11.7	6.9	3.88	0.3
E-4	0.13	0.50	29	0.0320	4.0					195	0.0320	3.6	0.9	5.0	11.2	5.0	4.26	0.3
E-5	0.14	0.50	64	0.0492	5.1					193	0.0492	4.5	0.7	5.8	11.4	5.8	4.10	0.3
E-6	0.18	0.65	118	0.0200	6.9	387	0.0200	2.3	2.8					9.8	12.8	9.8	3.30	0.4
O-1	0.10	0.50	51	0.0200	6.2	230	0.0200	2.3	1.7					7.8	11.6	7.8	3.69	0.2
O-2	0.15	0.51								416	0.0179	2.7	2.5	5.0	12.3	5.0	4.26	0.3
O-3	5.43	0.50	212	0.0400	10.0					610	0.0340	3.7	2.7	12.7	14.6	12.7	2.95	8.0
O-4	8.58	0.50	324	0.0384	12.5	587	0.0276	2.7	3.6					16.1	15.1	15.1	2.68	11.5
O-5	6.13	0.50	217	0.0337	10.7	823	0.0202	2.3	6.0					16.6	15.8	15.8	2.63	8.1
O-6	0.29	0.50	168	0.0576	7.9	80	0.0576	3.9	0.3					8.2	11.4	8.2	3.61	0.5
O-7	1.26	0.50	305	0.0428	11.7	180	0.0298	2.8	1.1					12.7	12.7	12.7	2.94	1.9
O-8	1.44	0.50	176	0.0372	9.3	391	0.0310	2.8	2.3					11.6	13.1	11.6	3.07	2.2
O-9	5.15	0.50	133	0.0235	9.4	499	0.0187	2.2	3.8					13.2	13.5	13.2	2.89	7.4
O-10	5.60	0.50	238	0.0245	12.4	777	0.0271	2.7	4.9					17.3	15.6	15.6	2.64	7.4

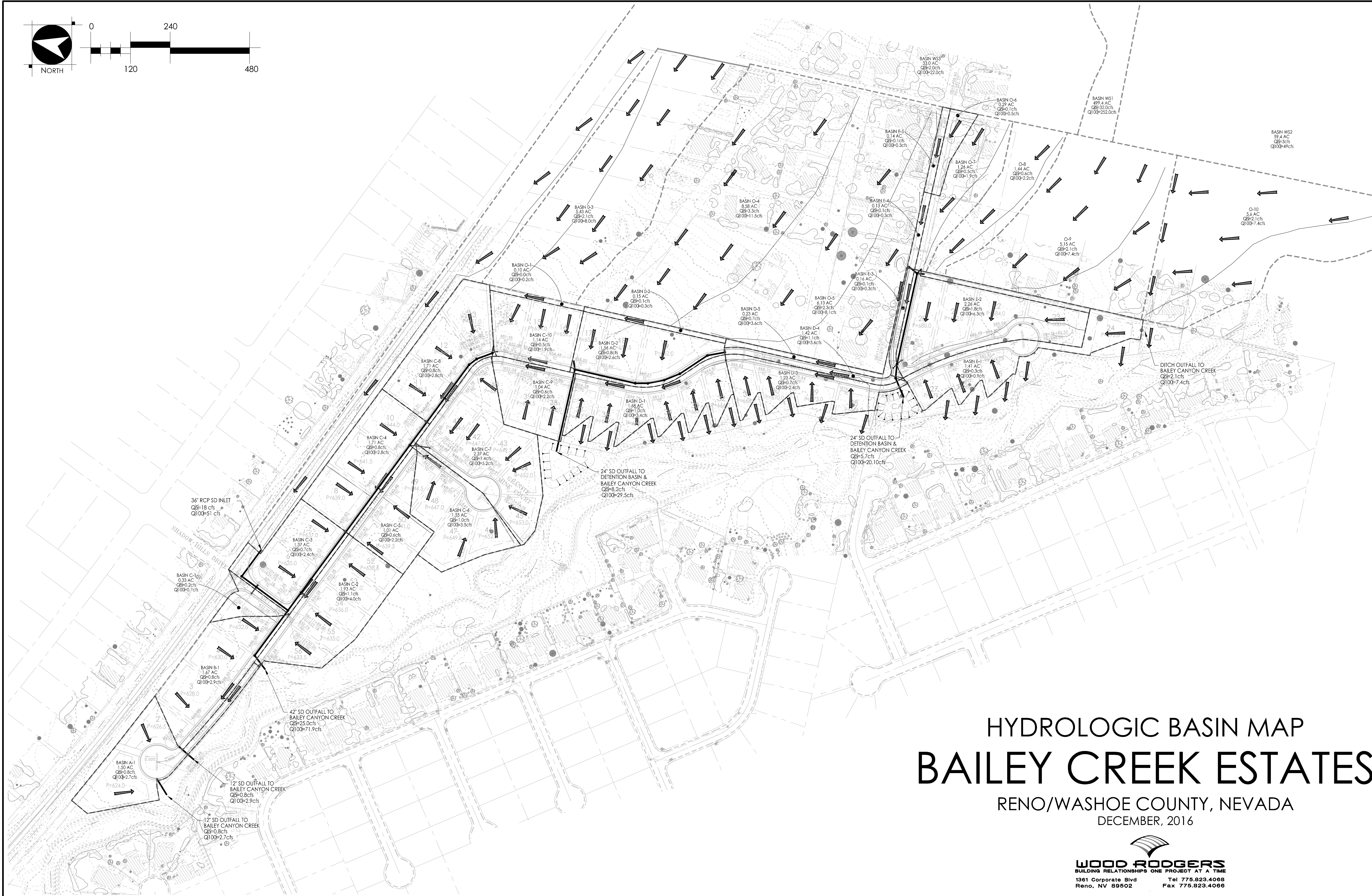
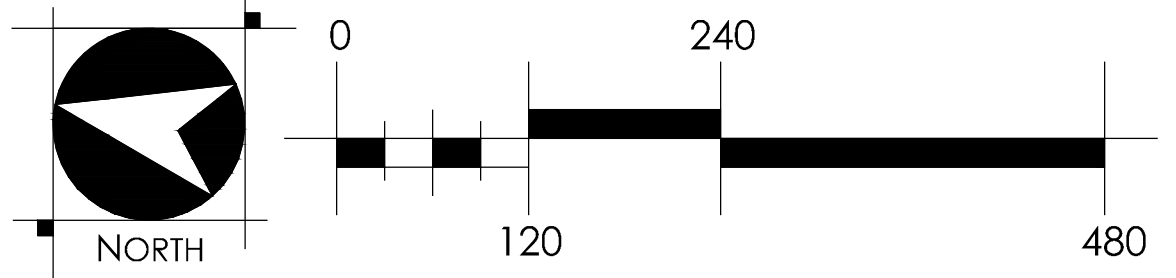

HYDROLOGIC BASIN MAP

BAILEY CREEK ESTATES

RENO/WASHOE COUNTY, NEVADA
DECEMBER, 2016

WOOD RODGERS
BUILDING RELATIONSHIPS ONE PROJECT AT A TIME
1361 Corporate Blvd Reno, NV 89502
Tel 775.823.4068 Fax 775.823.4066

BAILEY CREEK ESTATES - HYDROLOGY BASIN MAP

J:\Yuba\1324-Cottonwood_Creek_Bailey_Creek_OA\Civil\Exhibits\Drainage\VR_HYDRD_CCE.dwg 12/15/2016 12:52 PM Steve Babbers

BAILEY CREEK ESTATES

TENTATIVE MAP

TITLE SHEET

OWNER:

CHARLES B. MADDOX PO
BOX 70577 RENO, NV 89570

APPLICANT:

STL COMPANY, LLC.
16500 WEDGE PARKWAY,
BLDG A, STE 200 RENO, NV

BASIS OF BEARINGS

NEVADA STATE PLANE COORDINATE SYSTEM, WEST ZONE, NORTH AMERICAN DATUM OF 1983/1994, HIGH ACCURACY REFERENCE NETWORK (NAD 83/94 - HARN), AS DETERMINED USING REAL TIME KINEMATIC (RTK) GPS OBSERVATIONS WITH CORRECTIONS TRANSMITTED BY THE NORTHERN NEVADA COOPERATIVE REAL TIME NETWORK GPS (NNCRN GPS). THE BEARINGS BETWEEN GPS REFERENCE STATION "WSZOLEZZI" - S625M01279 AND "RNW RENO" - N745M01028 IS TAKEN AS NORTH 40°39'41" WEST. ALL DIMENSIONS SHOWN ARE GROUND DISTANCES. COMBINED GRID - TO - GROUND FACTOR = 1.000197939.

BASIS OF ELEVATION

THE BASIS OF ELEVATION IS BASED ON THE NORTH AMERICAN VERTICAL DATUM OF 1988 (NAVD 88) AS TAKEN FROM CITY OF RENO BENCHMARK 3091, WITH A PUBLISHED ELEVATION OF 4555.77 FT. BENCHMARK 3091 IS DESCRIBED AS BEING 1/2" DIA STEEL CAP - AT SW'LY TRAFFIC ISLAND OF VETERANS PKWY AND CURTI RANCH RD - 7" NW'LY OF S'LY APEX OF THE ISLAND.

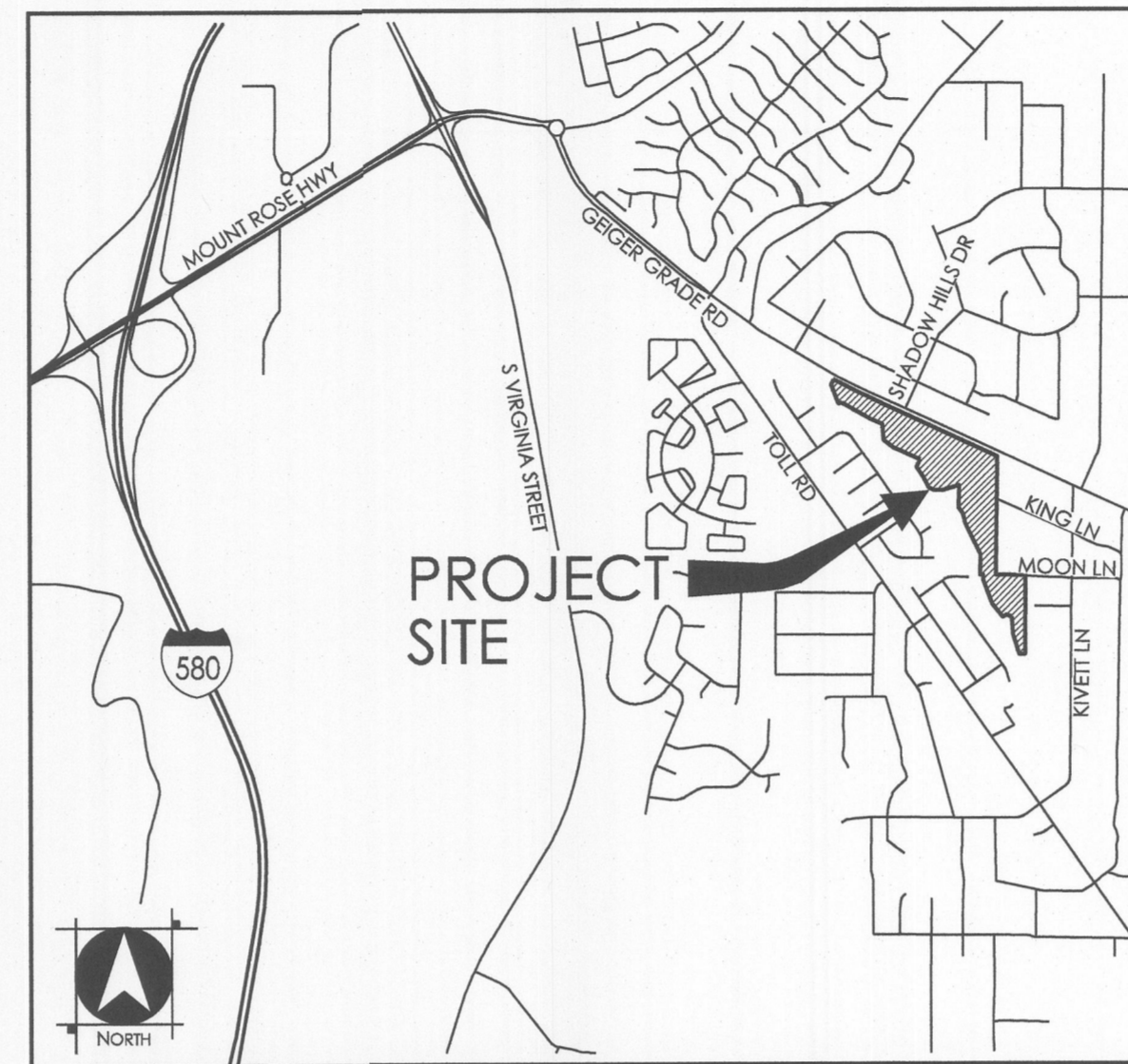

VICINITY MAP
NOT TO SCALE



SITE PLAN
NOT TO SCALE

SITE INFORMATION:

LOT SUMMARY
SITE AREA: 28.76 AC
LARGEST LOT AREA: 0.81 AC
SMALLEST LOT AREA: 0.33 AC
AVERAGE LOT AREA: 0.41 AC

COMMON AREA
COMMON AREA 1: 0.05 AC
COMMON AREA 2: 0.28 AC
COMMON AREA 3: 0.05 AC
COMMON AREA 4: 0.24 AC
COMMON AREA 5: 0.13 AC
TOTAL COMMON AREA: 0.75 AC

ASSESSOR PARCEL NUMBER
017-520-03, 017-480-02

ENGINEERS STATEMENT:

I, STEVEN P. STRICKLAND, DO HEREBY CERTIFY THAT THIS PLAN HAS BEEN PREPARED BY ME OR UNDER MY SUPERVISION AND WAS COMPLETED ON THE 15th DAY OF DECEMBER, 2016.

Steven P. Strickland 12/15/16
STEVEN P. STRICKLAND, P.E. #51192



SHEET INDEX

SHT No.	DWG ID	DRAWING DESCRIPTION
1	T-1	TITLE SHEET
2	LB-1	PRELIMINARY LOT AND BLOCK PLAN
3	G-1	PRELIMINARY GRADING PLAN
4	U-1	PRELIMINARY UTILITY PLAN
5	L-1	PRELIMINARY LANDSCAPE PLAN

BAILEY CREEK ESTATES
TITLE SHEET

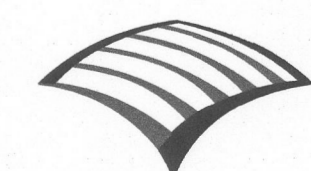

WOOD RODGERS
BUILDING RELATIONSHIPS ONE PROJECT AT A TIME
1361 Corporate Blvd Reno, NV 89502
Tel 775.823.4068 Fax 775.823.4066

1324006

DECEMBER, 2016

SHEET T-1 OF 5

BAILEY CREEK ESTATES

TENTATIVE MAP

PRELIMINARY LOT AND BLOCK PLAN

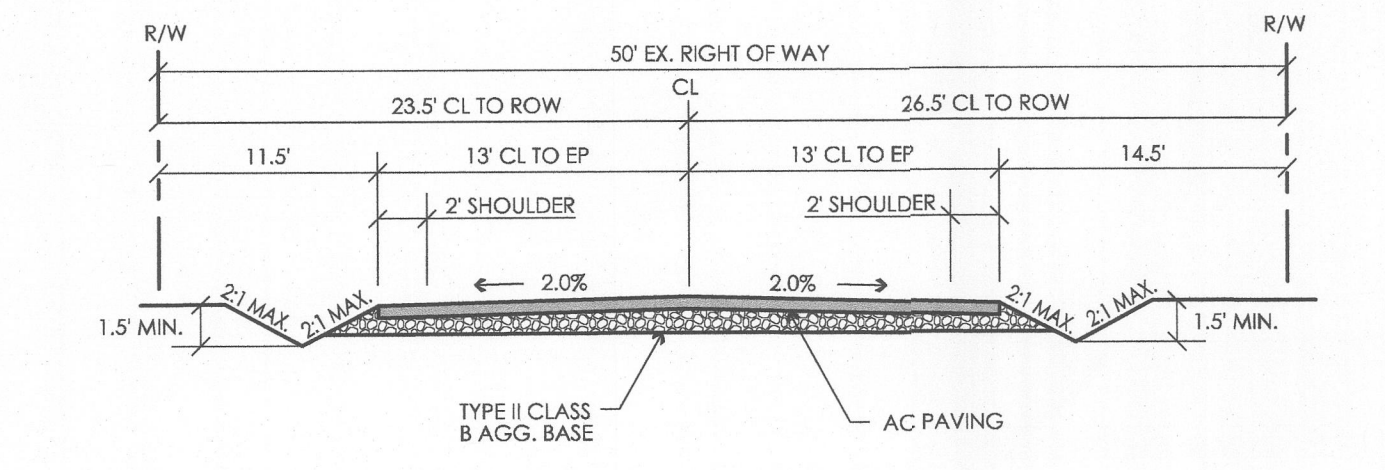
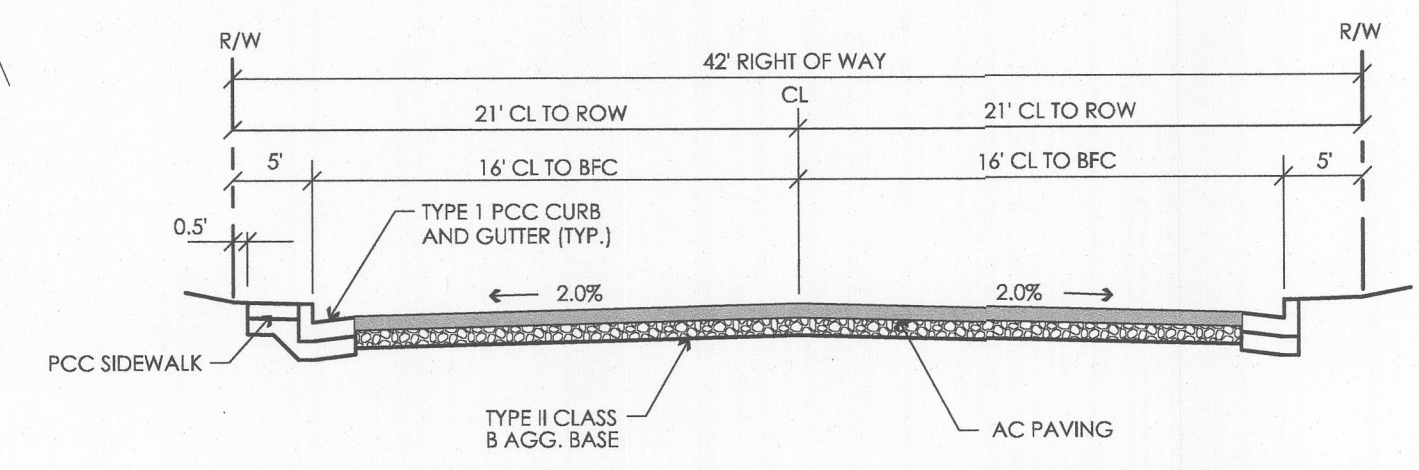
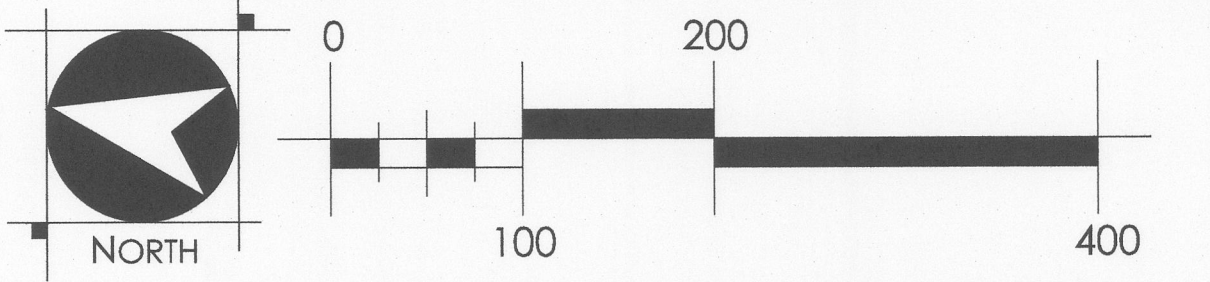

BAILEY CREEK ESTATES

PRELIMINARY LOT AND BLOCK PLAN

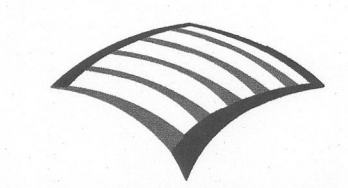

WOOD RODGERS
BUILDING RELATIONSHIPS ONE PROJECT AT A TIME
1361 Corporate Blvd Reno, NV 89502
Tel 775.823.4068 Fax 775.823.4066

1324006 DECEMBER, 2016
SHEET LB-1 OF 5

BAILEY CREEK ESTATES

TENTATIVE MAP

PRELIMINARY GRADING PLAN



GRADING STATISTICS

ESTIMATED CUT	50,000 cu.yd.
ESTIMATED FILL	50,000 cu.yd.
AREA OF DISTURBANCE	2.3 Ac

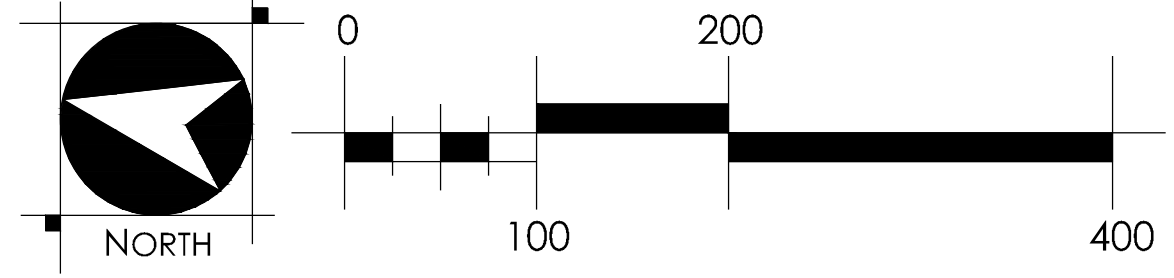

BAILEY CREEK ESTATES PRELIMINARY GRADING PLAN

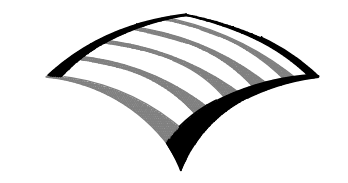

WOOD RODGERS
BUILDING RELATIONSHIPS ONE PROJECT AT A TIME

1361 Corporate Blvd Tel 775.823.4068
Reno, NV 89502 Fax 775.823.4066

1324006 DECEMBER, 2016

SHEET G-1 OF 5

J:\Vabs\1324-Cottonwood Creek\Bailey_Creek_OA\Planning\Draw\Tentative\Map\03_B.C_C01.dwg 12/22/2016 3:02 PM Todd Gammill

BAILEY CREEK ESTATES

TENTATIVE MAP

PRELIMINARY UTILITY PLAN

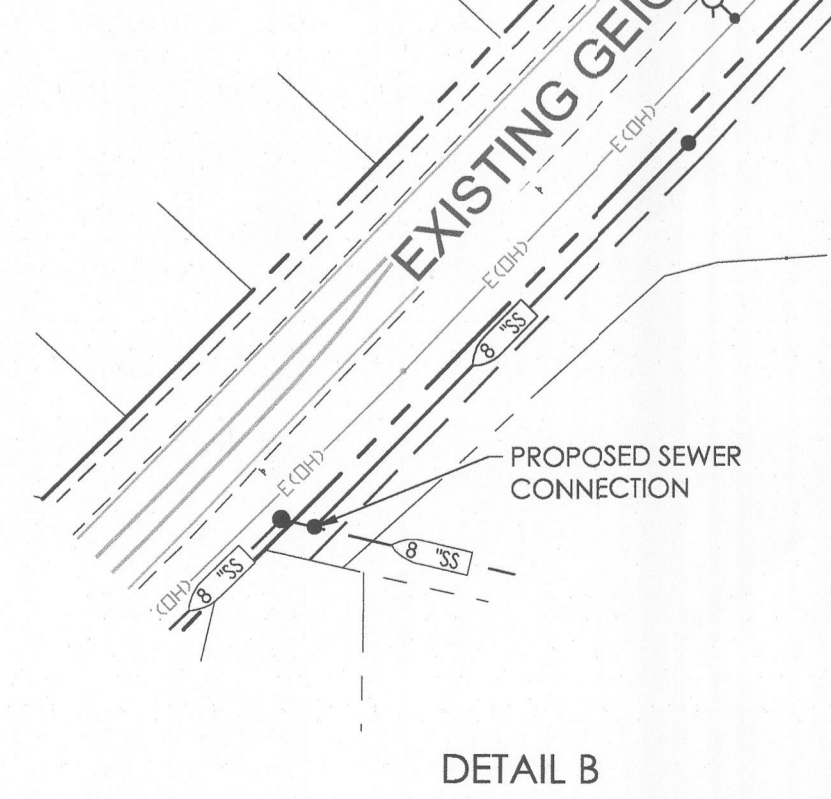
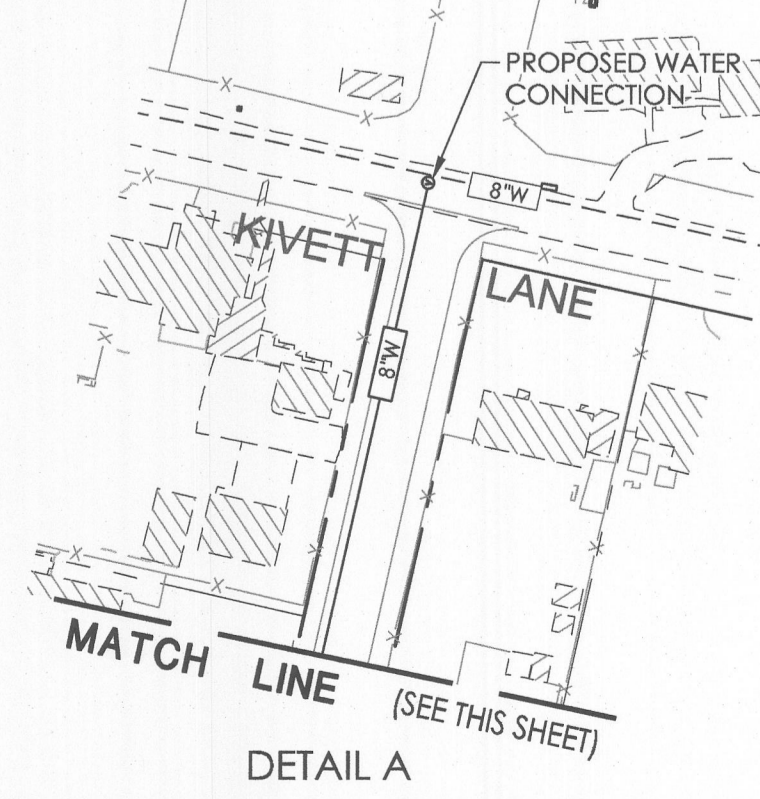
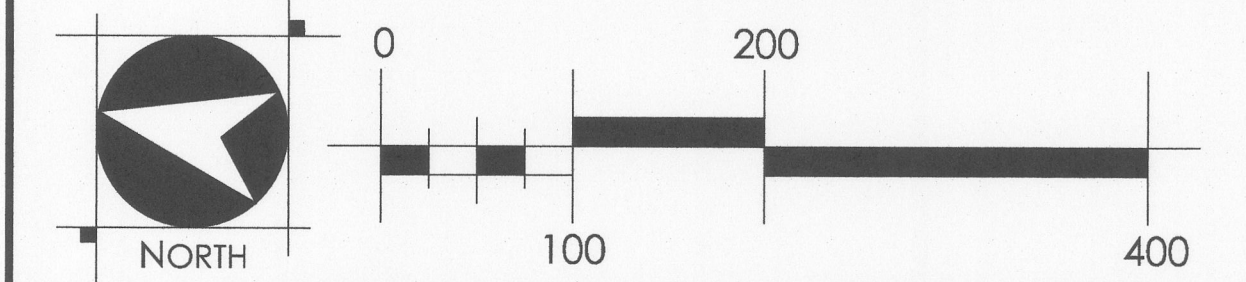

BAILEY CREEK ESTATES PRELIMINARY UTILITY PLAN

WOOD RODGERS
 BUILDING RELATIONSHIPS ONE PROJECT AT A TIME
 1361 Corporate Blvd Tel 775.823.4068
 Reno, NV 89502 Fax 775.823.4066

1324006 DECEMBER, 2016
 SHEET U-1 OF 5

J:\data\1324-Cottonwood_Creek\Bailey_Creek_OA\Planning\Draw\Tentative\Map\TM_U1.dwg 12/15/2016 3:05 PM Steve Babierz

BAILEY CREEK ESTATES

TRAFFIC STUDY

DECEMBER, 2016



Solaegui
12-28-16
EXP 6-30-18

Prepared by:
Solaegui Engineers, Ltd.
715 H Street
Sparks, Nevada 89431
(775) 358-1004

TABLE OF CONTENTS

EXECUTIVE SUMMARY.....	3
INTRODUCTION.....	4
STUDY AREA.....	4
EXISTING AND PROPOSED LAND USES.....	4
EXISTING AND PROPOSED ROADWAYS AND INTERSECTIONS	4
TRIP GENERATION.....	6
TRIP DISTRIBUTION AND ASSIGNMENT	6
EXISTING AND PROJECTED TRAFFIC VOLUMES.....	6
INTERSECTION CAPACITY ANALYSIS.....	13
SITE PLAN REVIEW.....	15
RECOMMENDATIONS	15
APPENDIX	16

LIST OF FIGURES

FIGURE 1 - VICINITY MAP.....	5
FIGURE 2 – TRIP DISTRIBUTION.....	7
FIGURE 3 - TRIP ASSIGNMENT	8
FIGURE 4 - EXISTING TRAFFIC VOLUMES	9
FIGURE 5 - EXISTING PLUS PROJECT TRAFFIC VOLUMES.....	10
FIGURE 6 - 2026 BASE TRAFFIC VOLUMES.....	11
FIGURE 7 - 2026 BASE PLUS PROJECT TRAFFIC VOLUMES	12

BAILEY CREEK ESTATES

TRAFFIC STUDY

EXECUTIVE SUMMARY

The proposed Bailey Creek Estates development is located in Washoe County, Nevada. The project site is located south of Geiger Grade, east of Toll Road and west of Kivett Lane. The project site is currently undeveloped land. The purpose of this study is to address the project's impact upon the adjacent street network. The Geiger Grade/Shadow Hills Drive intersection has been identified for AM and PM peak hour capacity analysis for the existing, existing plus project, 2026 base, and 2026 base plus project scenarios.

The proposed Bailey Creek Estates development will include the construction of a residential subdivision containing 56 single family homes. Project access will be provided from the extension of Shadow Hills Drive south of Geiger Grade. The project is anticipated to generate 533 average daily trips with 42 trips occurring during the AM peak hour and 56 trips occurring during the PM peak hour.

Traffic generated by the proposed Bailey Creek Estates development will have some impact on the adjacent street network. The following recommendations are made to mitigate project traffic impacts.

It is recommended that any required signing, striping or traffic control improvements comply with Nevada Department of Transportation and Washoe County requirements.

It is recommended that the Geiger Grade/Shadow Hills Drive intersection be improved as a four-leg intersection with stop sign control at the north and south approaches. The west approach shall contain an exclusive right turn lane containing 220 feet of deceleration length with a 15:1 taper.

It is recommended that the on-site roadways and cul-de-sacs be designed per Washoe County standards.

INTRODUCTION

STUDY AREA

The proposed Bailey Creek Estates development is located in Washoe County, Nevada. The project site is located south of Geiger Grade, east of Toll Road and west of Kivett Lane. Figure 1 shows the approximate location of the project site. The purpose of this study is to address the project's impact upon the adjacent street network. The Geiger Grade/Shadow Hills Drive intersection has been identified for AM and PM peak hour capacity analysis for the existing, existing plus project, 2026 base, and 2026 base plus project scenarios.

EXISTING AND PROPOSED LAND USES

The project site is currently undeveloped land. Adjacent land generally includes single family dwelling units to the north, south, east and west. The proposed Bailey Creek Estates development will include the construction of a residential subdivision containing 56 single family detached homes. Project access will be provided from the extension of Shadow Hills Drive south of Geiger Grade.

EXISTING AND PROPOSED ROADWAYS AND INTERSECTIONS

Geiger Grade (State Route 341) is a two-lane roadway with one through lane in each direction in the vicinity of the site. The speed limit is posted for 45 miles per hour adjacent to the site. Roadway improvements generally include graded shoulders with solid white edgelines and a double solid yellow centerline.

Shadow Hills Drive is a two-lane roadway with one through lane in each direction north of Geiger Grade. The speed limit is posted for 25 miles per hour. Roadway improvements generally include curb and gutter on both sides of the street. With development of the project, Shadow Hills Drive will be extended south of Geiger grade to provide access to the site.

The Geiger Grade/Shadow Hills Drive intersection is an unsignalized three-leg intersection with stop sign control at the north approach. The north approach contains one shared left turn-right turn lane. The west approach contains one shared left turn-through lane. The east approach contains one shared through-right turn lane. With development of the project, the Geiger Grade/Shadow Hills Drive intersection will be improved as a four-leg intersection with stop sign control at the north and south approaches.

LEGEND

PROJECT SITE

N.T.S.



BAILEY CREEK ESTATES
VICINITY MAP
FIGURE 1

TRIP GENERATION

In order to assess the magnitude of traffic impacts of the proposed project at the key intersection, trip generation rates and peak hours had to be determined. Trip generation rates were obtained from the Ninth Edition of *ITE Trip Generation* (2012) for Land Use 210 “Single Family Detached Housing”. The proposed Bailey Creek Estates development will include the construction of a residential subdivision containing 56 single family homes. Trips generated by the project were calculated for an average weekday and the weekday peak hours occurring between 7:00 AM and 9:00 AM and 4:00 PM and 6:00 PM, which correspond to the peak hours of adjacent street traffic. Table 1 shows a summary of the average daily traffic (ADT) and peak hour volumes generated by the proposed development.

LAND USE	ADT	AM PEAK HOUR			PM PEAK HOUR		
		IN	OUT	TOTAL	IN	OUT	TOTAL
Single Family Detached Housing (56 D.U.)	533	11	31	42	35	21	56

TRIP DISTRIBUTION AND ASSIGNMENT

The distribution of the project traffic to the key intersection was based on existing peak hour traffic patterns and the locations of attractions and productions in the area. Figure 2 shows the anticipated trip distribution. The peak hour trips shown in Table 1 were subsequently assigned to the key intersection based on the trip distribution. Figure 3 shows the trip assignment at the key intersection for the AM and PM peak hours.

EXISTING AND PROJECTED TRAFFIC VOLUMES

Figure 4 shows the existing traffic volumes during the AM and PM peak hours. The existing AM and PM peak hour volumes were obtained from traffic counts taken in December of 2016. Figure 5 shows the existing plus project AM and PM peak hour traffic volumes. The existing plus project traffic volumes were obtained by adding the project trips to the existing traffic volumes. Figure 6 shows the 2026 base traffic volumes during the AM and PM peak hours. The 2026 base traffic volumes were estimated by applying a 1.0% average annual growth rate to the existing traffic volumes. A negative growth rate was derived from 10-year historic traffic count data obtained from the Nevada Department of Transportation’s (NDOT) Annual Traffic Report for count station 0311031 on Geiger Grade. However, the 1.0% growth rate was used in order to ensure conservative results. Figure 7 shows the 2026 base plus project traffic volumes. These volumes were obtained by adding traffic volumes generated by the project to the 2026 base traffic volumes.

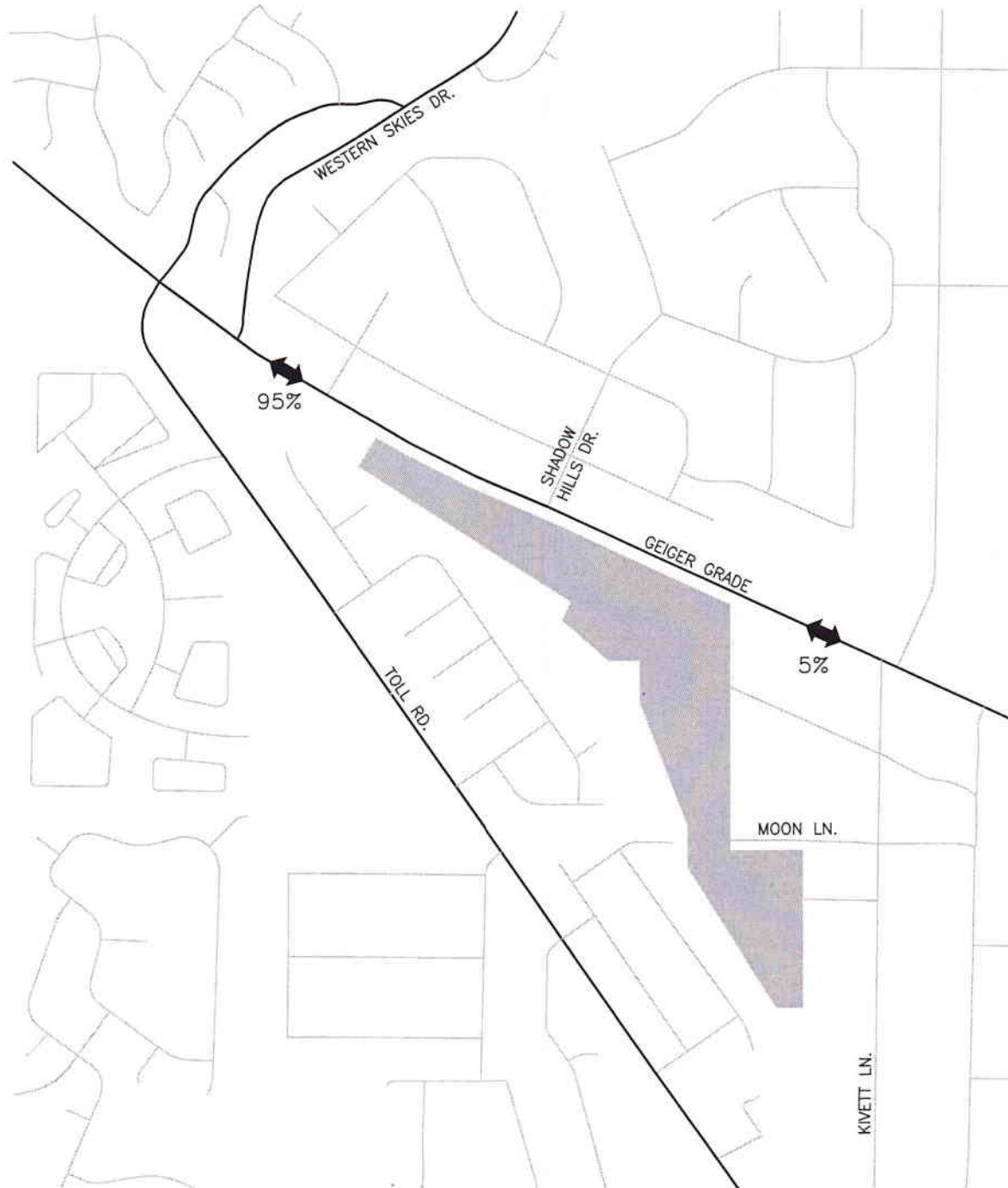

BAILEY CREEK ESTATES
TRIP DISTRIBUTION
FIGURE 2

LEGEND

- AM PEAK HOUR
- (-) PM PEAK HOUR

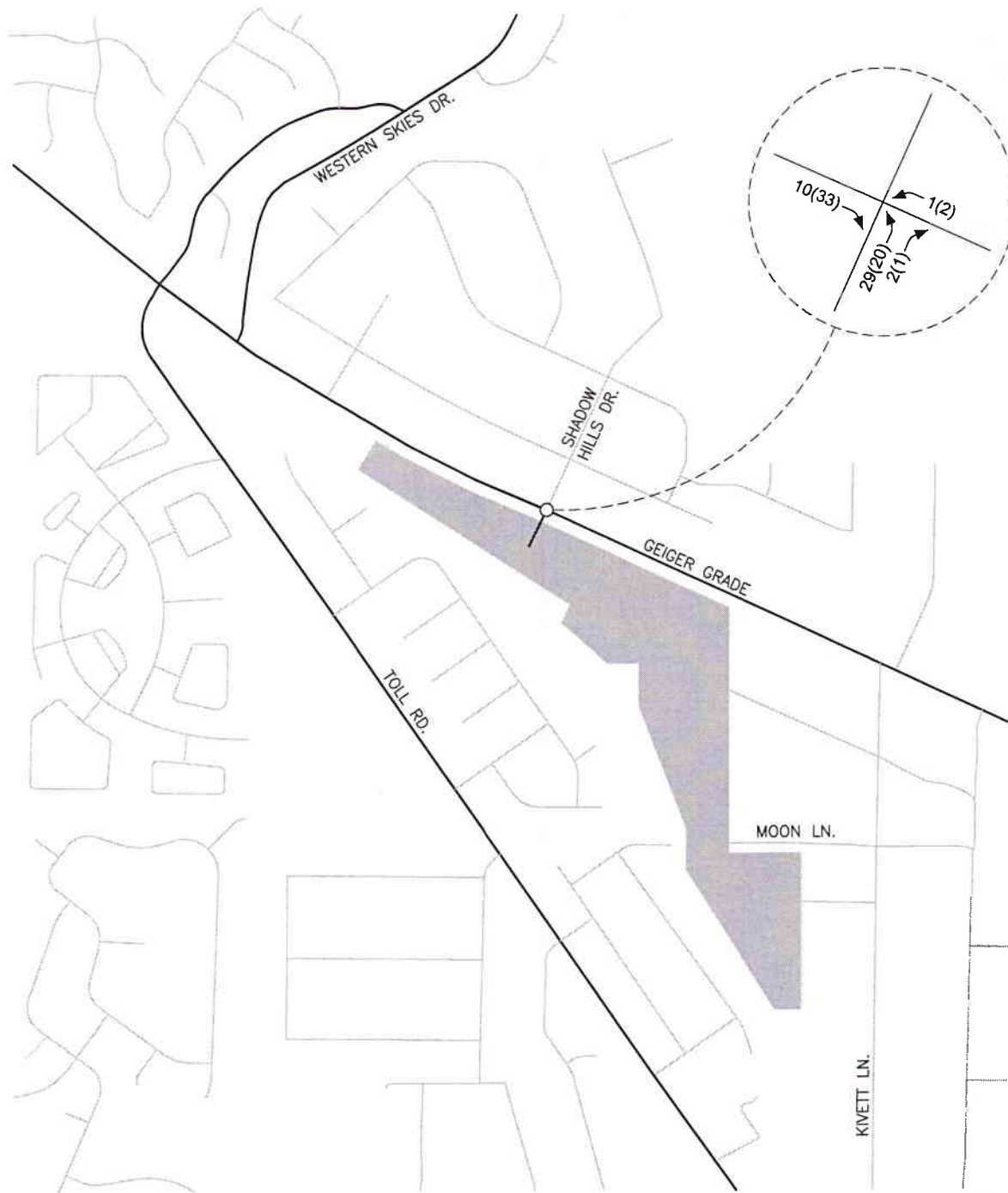

BAILEY CREEK ESTATES
TRIP ASSIGNMENT
FIGURE 3

LEGEND
— AM PEAK HOUR
(-) PM PEAK HOUR

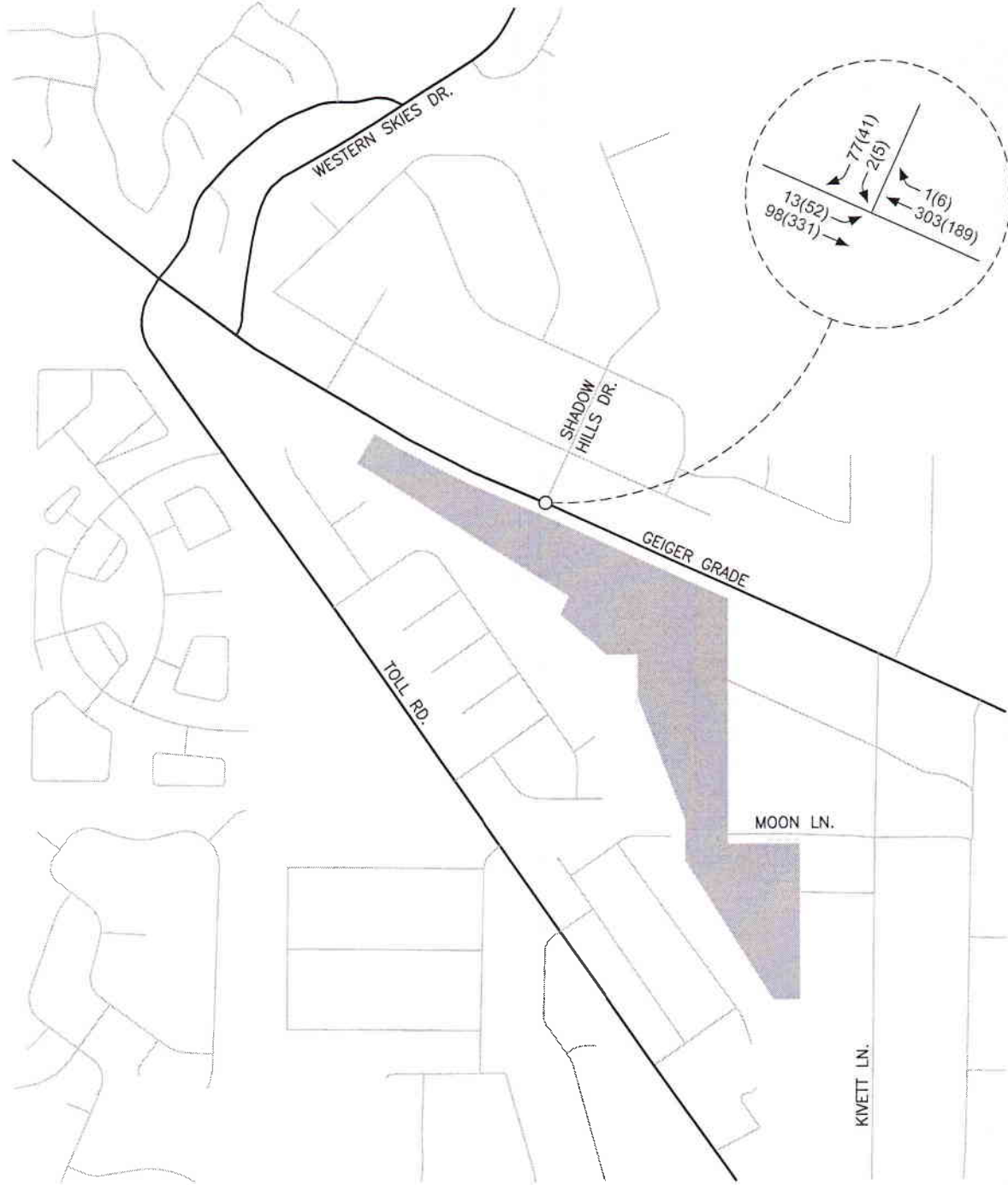

BAILEY CREEK ESTATES
EXISTING TRAFFIC VOLUMES
FIGURE 4

LEGEND

- AM PEAK HOUR
- (-) PM PEAK HOUR



BAILEY CREEK ESTATES
EXISTING PLUS PROJECT TRAFFIC VOLUMES
FIGURE 5

LEGEND
- AM PEAK HOUR
(-) PM PEAK HOUR

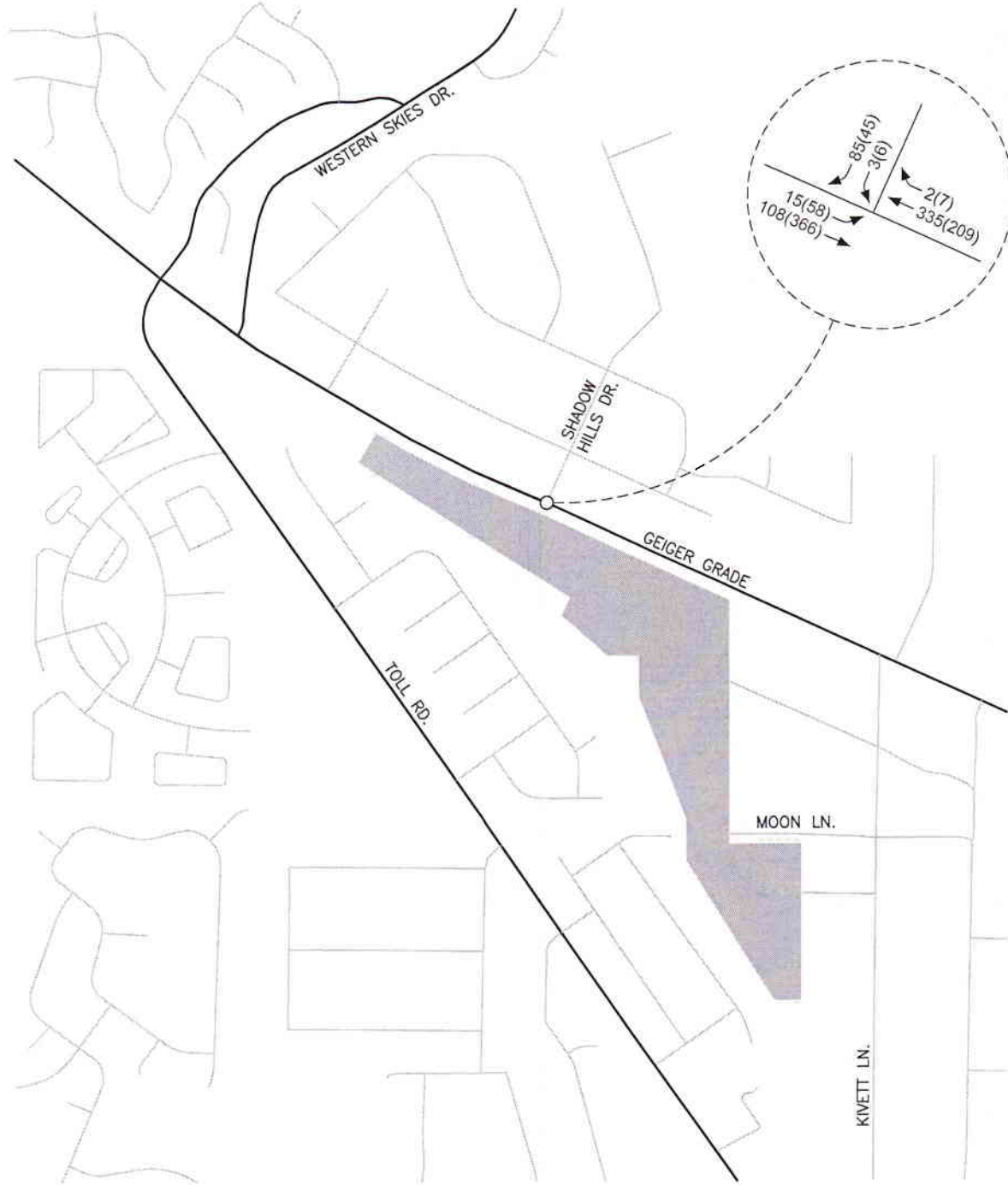

BAILEY CREEK ESTATES
2026 BASE TRAFFIC VOLUMES
FIGURE 6

LEGEND

- AM PEAK HOUR
- (-) PM PEAK HOUR

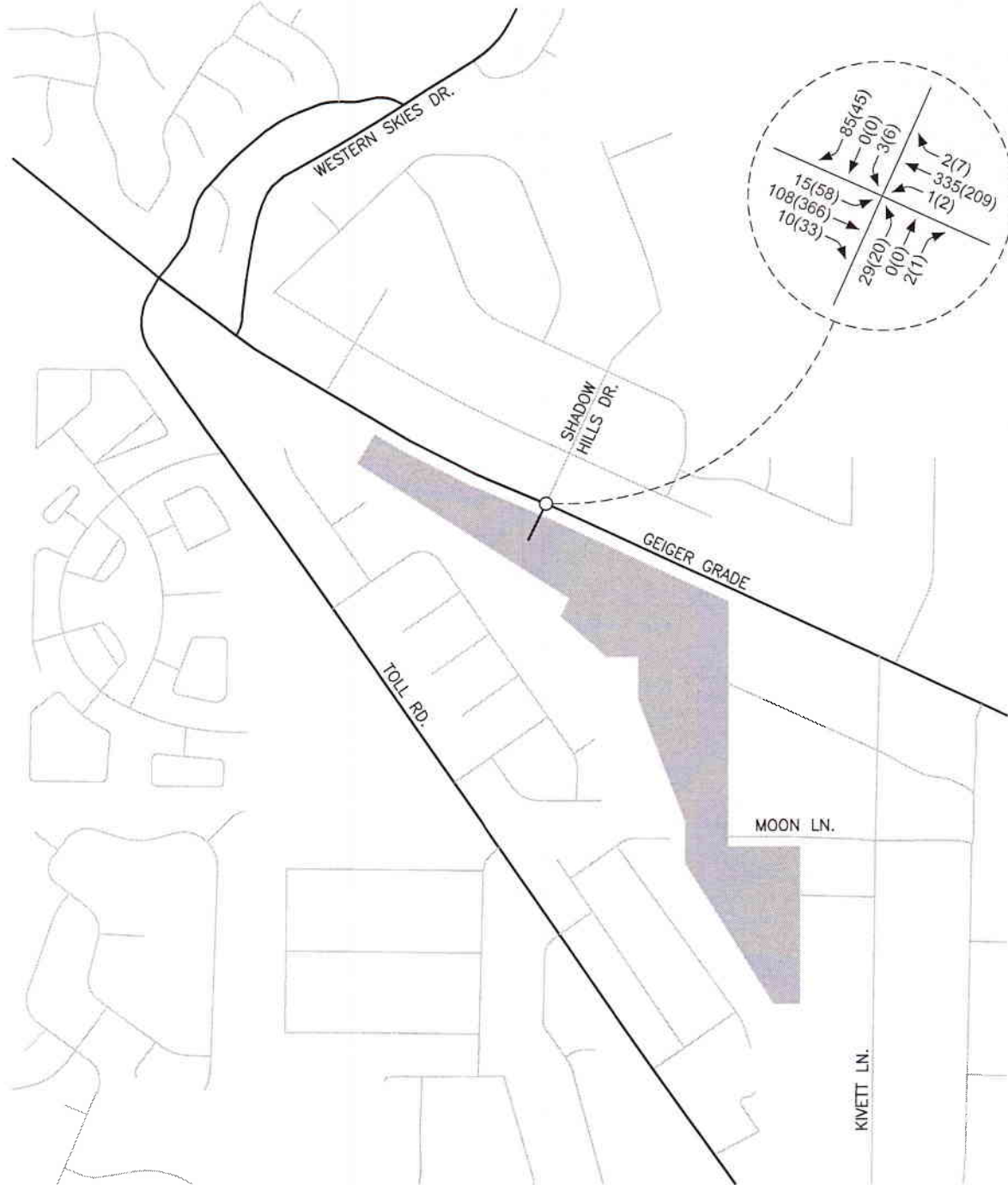

BAILEY CREEK ESTATES

**2026 BASE PLUS PROJECT TRAFFIC VOLUMES
FIGURE 7**

INTERSECTION CAPACITY ANALYSIS

The Geiger Grade/Shadow Hills Drive intersection was analyzed for capacity based on procedures presented in the 2010 *Highway Capacity Manual (HCM)*, prepared by the Transportation Research Board, for unsignalized intersections using the latest version of the Highway Capacity software. The result of capacity analysis is a level of service rating for each intersection minor movement. Level of service is a qualitative measure of traffic operating conditions where a letter grade “A” through “F”, corresponding to progressively worsening traffic operation, is assigned to the minor movement.

The *Highway Capacity Manual* defines level of service for stop controlled intersections in terms of computed or measured control delay for each minor movement. Level of service is not defined for the intersection as a whole. The level of service criteria for unsignalized intersections is shown in Table 2.

LEVEL OF SERVICE	DELAY RANGE (SEC/VEH)
A	≤10
B	>10 and ≤15
C	>15 and ≤25
D	>25 and ≤35
E	>35 and ≤50
F	>50

Table 3 shows a summary of the level of service and delay results for the existing, existing plus project, 2026 base, and 2026 base plus project scenarios. The capacity worksheets are included in the Appendix.

INTERSECTION	EXISTING		EXISTING + PROJECT		2026 BASE		2026 BASE + PROJECT	
	AM	PM	AM	PM	AM	PM	AM	PM
Geiger Grade/Shadow Hills Stop at North Leg								
EB Left	A8.0	A7.8	N/A	N/A	A8.1	A7.9	N/A	N/A
SB Left-Right	B10.8	B10.2	N/A	N/A	B11.3	B10.6	N/A	N/A
Geiger Grade/Shadow Hills Stop at North and South Legs								
EB Left	N/A	N/A	A8.0	A7.8	N/A	N/A	A8.1	A7.9
WB Left	N/A	N/A	A7.5	A8.1	N/A	N/A	A7.5	A8.2
NB Left-Thru-Right	N/A	N/A	B14.2	C17.4	N/A	N/A	C15.3	C19.3
SB Left-Thru-Right	N/A	N/A	B10.8	B10.4	N/A	N/A	B11.3	B10.9

The Geiger Grade/Shadow Hills Drive intersection was analyzed as an unsignalized three-leg intersection with stop sign control at the north approach for the existing and 2026 base scenarios and an unsignalized four-leg intersection with stop sign control at the north and south approaches for the existing plus project and 2026 base plus project scenarios. The intersection minor movements currently operate at LOS B or better during the AM and PM peak hours and will continue to do so for the 2026 base traffic volumes. For the existing plus project volumes the intersection minor movements operate at LOS C or better during the AM and PM peak hours. For the 2026 base plus project volumes the intersection minor movements continue to operate at LOS C or better during the AM and PM peak hours. The intersection was analyzed with the existing approach lanes for the existing and 2026 base scenarios and with single lanes at all approaches for the existing plus project and 2026 base plus project scenarios.

The need for an exclusive westbound to southbound left turn lane was reviewed at the Geiger Grade/Shadow Hills Drive intersection based on NDOT's access management standards. The access management standards list design hour volumes and operating speeds which necessitate the installation of left turn lanes on two-lane roads at unsignalized intersections. The traffic volume movements to be considered include advancing traffic volumes, opposing traffic volumes, and the percent of advancing traffic which is turning left. An exclusive westbound to southbound left turn lane is not required at the Geiger Grade/Shadow Hills Drive intersection based on the 2026 base plus project traffic volumes.

The need for an exclusive eastbound to southbound right turn lane was reviewed at the Geiger Grade/Shadow Hills Drive intersection based on NDOT's access management standards. The access management standards indicates that right turn deceleration lanes are required at Class III accesses (access to land uses that generate 500 or more trips per day) on roadways with speeds greater than 35 miles per hour. A right turn deceleration lane is required at this location since the project is anticipated to generate 533 trips per day and the speed limit on Geiger Grade is posted for 45 miles per hour. The right turn lane should contain 220 feet of deceleration length with a 15:1 taper based on the 45 mile per hour speed limit on Geiger Grade.

It is recommended that the Geiger Grade/Shadow Hills Drive intersection be improved as a four-leg intersection with stop sign control at the north and south approaches. The west approach shall contain an exclusive right turn lane containing 220 feet of deceleration length with a 15:1 taper.

SITE PLAN REVIEW

A copy of the preliminary site plan for the Bailey Creek Estates development is included with this submittal. The site plan indicates that project access will be provided from the extension of Shadow Hills Drive south of Geiger Grade to Sterling Hills Way. Sterling Hills Way will be constructed through the center of the development and, along with Granite Mine Court, will provide access to the individual lots. The site plan also indicates that Moon Lane will be constructed from Sterling Hills Way to the project's east property line. The site plan specifies that an emergency access gate will be constructed on this segment of Moon Lane. It is recommended that the on-site roadways and cul-de-sacs be designed per Washoe County standards.

Spacing requirements were subsequently reviewed for the Geiger Grade project access based on NDOT's access management standards. The access management standards indicate that spacing for unsignalized driveways shall be a minimum of 350 feet based on the 45 mile per hour speed limit on Geiger Grade. The existing Shadow Hills Drive intersection is located approximately 1,250 feet east of High Chaparral Way and approximately 1,000 feet west of an existing driveway serving a convenience store. The 350 feet spacing requirement is met.

RECOMMENDATIONS

Traffic generated by the proposed Bailey Creek Estates development will have some impact on the adjacent street network. The following recommendations are made to mitigate project traffic impacts.

It is recommended that any required signing, striping or traffic control improvements comply with Nevada Department of Transportation and Washoe County requirements.

It is recommended that the Geiger Grade/Shadow Hills Drive intersection be improved as a four-leg intersection with stop sign control at the north and south approaches. The west approach shall contain an exclusive right turn lane containing 220 feet of deceleration length with a 15:1 taper.

It is recommended that the on-site roadways and cul-de-sacs be designed per Washoe County standards.

APPENDIX

Trip Generation Summary - Alternative 1

Project: New Project
 Alternative: Alternative 1

Open Date: 12/22/2016
 Analysis Date: 12/22/2016

ITE	Land Use	Average Daily Trips			AM Peak Hour of Adjacent Street Traffic			PM Peak Hour of Adjacent Street Traffic		
		Enter	Exit	Total	Enter	Exit	Total	Enter	Exit	Total
210	SFHOUSE 1	267	266	533	11	31	42	35	21	56
	56 Dwelling Units									
Unadjusted Volume		0	0	0	0	0	0	0	0	0
Internal Capture Trips		0	0	0	0	0	0	0	0	0
Pass-By Trips		0	0	0	0	0	0	0	0	0
Volume Added to Adjacent Streets		0	0	0	0	0	0	0	0	0

Total AM Peak Hour Internal Capture = 0 Percent

Total PM Peak Hour Internal Capture = 0 Percent

HCS 2010 Two-Way Stop-Control Report

General Information

Analyst	MSH
Agency/Co.	Solaegui Engineers
Date Performed	12/22/2016
Analysis Year	2016
Time Analyzed	AM Existing
Intersection Orientation	East-West
Project Description	

Site Information

Intersection	Geiger & Shadow Hills
Jurisdiction	NDOT
East/West Street	Geiger Grade
North/South Street	Shadow Hills Drive
Peak Hour Factor	0.92
Analysis Time Period (hrs)	0.25

Lanes

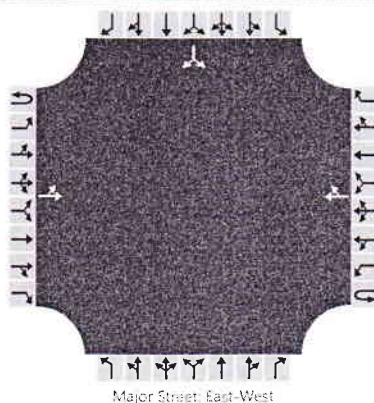

Vehicle Volumes and Adjustments

Approach	Eastbound				Westbound				Northbound				Southbound				
	U	L	T	R	U	L	T	R	U	L	T	R	U	L	T	R	
Movement	1U	1	2	3	4U	4	5	6	7	8	9			10	11	12	
Priority																	
Number of Lanes	0	0	1	0	0	0	1	0	0	0	0			0	0	0	
Configuration		LT						TR								LR	
Volume, V (veh/h)		13	98				303	1						2		77	
Percent Heavy Vehicles (%)		3												3		3	
Proportion Time Blocked																	
Percent Grade (%)																0	
Right Turn Channelized		No				No				No				No			
Median Type/Storage		Undivided															

Critical and Follow-up Headways

Base Critical Headway (sec)																	
Critical Headway (sec)																	
Base Follow-Up Headway (sec)																	
Follow-Up Headway (sec)																	

Delay, Queue Length, and Level of Service

Flow Rate, v (veh/h)		14														86	
Capacity, c (veh/h)		1223														704	
v/c Ratio		0.01														0.12	
95% Queue Length, Q ₉₅ (veh)		0.0														0.4	
Control Delay (s/veh)		8.0														10.8	
Level of Service, LOS		A														B	
Approach Delay (s/veh)		1.0												10.8			
Approach LOS														B			

HCS 2010 Two-Way Stop-Control Report

General Information				Site Information			
Analyst	MSH			Intersection	Geiger & Shadow Hills		
Agency/Co.	Solaegui Engineers			Jurisdiction	NDOT		
Date Performed	12/22/2016			East/West Street	Geiger Grade		
Analysis Year	2016			North/South Street	Shadow Hills Drive		
Time Analyzed	PM Existing			Peak Hour Factor	0.92		
Intersection Orientation	East-West			Analysis Time Period (hrs)	0.25		
Project Description							

Lanes

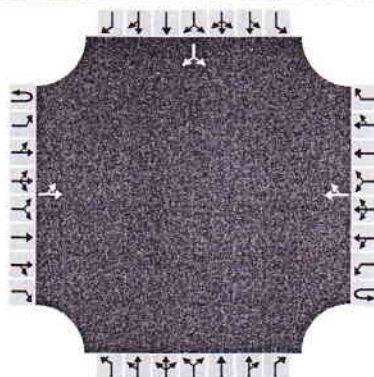

Major Street: East-West

Vehicle Volumes and Adjustments

Approach	Eastbound				Westbound				Northbound				Southbound			
	U	L	T	R	U	L	T	R	U	L	T	R	U	L	T	R
Movement	1U	1	2	3	4U	4	5	6		7	8	9		10	11	12
Priority																
Number of Lanes	0	0	1	0	0	0	1	0		0	0	0		0	0	0
Configuration		LT						TR							LR	
Volume, V (veh/h)		52	331				189	6						5		41
Percent Heavy Vehicles (%)		3												3		3
Proportion Time Blocked																
Percent Grade (%)																0
Right Turn Channelized		No			No				No				No			
Median Type/Storage		Undivided														

Critical and Follow-up Headways

Base Critical Headway (sec)																
Critical Headway (sec)																
Base Follow-Up Headway (sec)																
Follow-Up Headway (sec)																

Delay, Queue Length, and Level of Service

Flow Rate, v (veh/h)		57														50
Capacity, c (veh/h)		1351														748
v/c Ratio		0.04														0.07
95% Queue Length, Q ₉₅ (veh)		0.1														0.2
Control Delay (s/veh)		7.8														10.2
Level of Service, LOS		A														B
Approach Delay (s/veh)		1.4														10.2
Approach LOS																B

HCS 2010 Two-Way Stop-Control Report

General Information

Analyst	MSH
Agency/Co.	Solaegui Engineers
Date Performed	12/22/2016
Analysis Year	2016
Time Analyzed	AM Existing + Project
Intersection Orientation	East-West
Project Description	

Site Information

Intersection	Geiger & Shadow Hills
Jurisdiction	NDOT
East/West Street	Geiger Grade
North/South Street	Shadow Hills Drive
Peak Hour Factor	0.92
Analysis Time Period (hrs)	0.25

Lanes

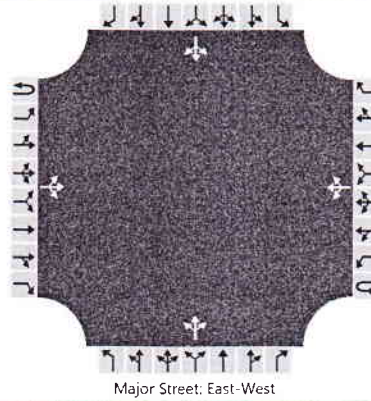

Vehicle Volumes and Adjustments

Approach	Eastbound				Westbound				Northbound				Southbound				
	U	L	T	R	U	L	T	R	U	L	T	R	U	L	T	R	
Movement	1U	1	2	3	4U	4	5	6		7	8	9		10	11	12	
Priority																	
Number of Lanes	0	0	1	0	0	0	1	0		0	1	0		0	1	0	
Configuration			LTR				LTR				LTR				LTR		
Volume, V (veh/h)		13	98	10		1	303	1		29	0	2		2	0	77	
Percent Heavy Vehicles (%)		3				3				3	3	3		3	3	3	
Proportion Time Blocked																	
Percent Grade (%)										0				0			
Right Turn Channelized		No				No				No				No			
Median Type/Storage	Undivided																

Critical and Follow-up Headways

Base Critical Headway (sec)																
Critical Headway (sec)																
Base Follow-Up Headway (sec)																
Follow-Up Headway (sec)																

Delay, Queue Length, and Level of Service

Flow Rate, v (veh/h)		14				1					34					86	
Capacity, c (veh/h)		1223				1462					423					702	
v/c Ratio		0.01				0.00					0.08					0.12	
95% Queue Length, Q ₉₅ (veh)		0.0				0.0					0.3					0.4	
Control Delay (s/veh)		8.0				7.5					14.2					10.8	
Level of Service, LOS		A				A					B					B	
Approach Delay (s/veh)		0.9				0.0				14.2				10.8			
Approach LOS										B				B			

HCS 2010 Two-Way Stop-Control Report

General Information

Analyst	MSH
Agency/Co.	Solaegui Engineers
Date Performed	12/22/2016
Analysis Year	2016
Time Analyzed	PM Existing + Project
Intersection Orientation	East-West
Project Description	

Site Information

Intersection	Geiger & Shadow Hills
Jurisdiction	NDOT
East/West Street	Geiger Grade
North/South Street	Shadow Hills Drive
Peak Hour Factor	0.92
Analysis Time Period (hrs)	0.25

Lanes

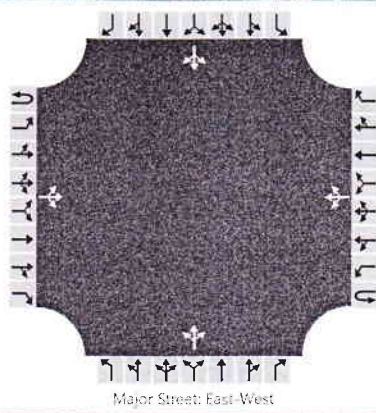

Vehicle Volumes and Adjustments

Approach	Eastbound				Westbound				Northbound				Southbound				
	U	L	T	R	U	L	T	R	U	L	T	R	U	L	T	R	
Movement	1U	1	2	3	4U	4	5	6		7	8	9		10	11	12	
Priority																	
Number of Lanes	0	0	1	0	0	0	1	0		0	1	0		0	1	0	
Configuration			LTR				LTR				LTR				LTR		
Volume, V (veh/h)		52	331	33		2	189	6		20	0	1		5	0	41	
Percent Heavy Vehicles (%)		3				3				3	3	3		3	3	3	
Proportion Time Blocked																	
Percent Grade (%)										0				0			
Right Turn Channelized		No				No				No				No			
Median Type/Storage	Undivided																

Critical and Follow-up Headways

Base Critical Headway (sec)																
Critical Headway (sec)																
Base Follow-Up Headway (sec)																
Follow-Up Headway (sec)																

Delay, Queue Length, and Level of Service

Flow Rate, v (veh/h)		57			2					23					50		
Capacity, c (veh/h)		1351			1156					313					722		
v/c Ratio		0.04			0.00					0.07					0.07		
95% Queue Length, Q ₉₅ (veh)		0.1			0.0					0.2					0.2		
Control Delay (s/veh)		7.8			8.1					17.4					10.4		
Level of Service, LOS		A			A					C					B		
Approach Delay (s/veh)		1.3				0.1				17.4				10.4			
Approach LOS										C				B			

HCS 2010 Two-Way Stop-Control Report

General Information

Analyst	MSH
Agency/Co.	Solaegui Engineers
Date Performed	12/22/2016
Analysis Year	2026
Time Analyzed	AM Base
Intersection Orientation	East-West
Project Description	

Site Information

Intersection	Geiger & Shadow Hills
Jurisdiction	NDOT
East/West Street	Geiger Grade
North/South Street	Shadow Hills Drive
Peak Hour Factor	0.92
Analysis Time Period (hrs)	0.25

Lanes

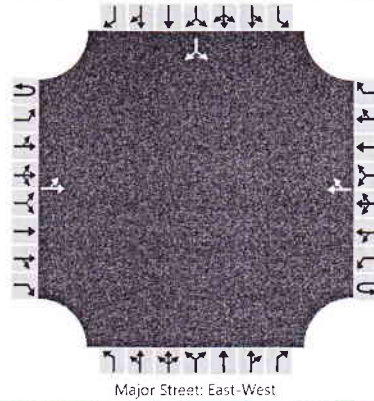

Vehicle Volumes and Adjustments

Approach	Eastbound				Westbound				Northbound				Southbound				
	U	L	T	R	U	L	T	R	U	L	T	R	U	L	T	R	
Movement	1U	1	2	3	4U	4	5	6		7	8	9		10	11	12	
Priority																	
Number of Lanes	0	0	1	0	0	0	1	0		0	0	0		0	0	0	
Configuration		LT						TR							LR		
Volume, V (veh/h)		15	108				335	2						3		85	
Percent Heavy Vehicles (%)		3												3		3	
Proportion Time Blocked																	
Percent Grade (%)																0	
Right Turn Channelized		No				No				No				No			
Median Type/Storage		Undivided															

Critical and Follow-up Headways

Base Critical Headway (sec)																	
Critical Headway (sec)																	
Base Follow-Up Headway (sec)																	
Follow-Up Headway (sec)																	

Delay, Queue Length, and Level of Service

Flow Rate, v (veh/h)		16														95	
Capacity, c (veh/h)		1186														671	
v/c Ratio		0.01														0.14	
95% Queue Length, Q ₉₅ (veh)		0.0														0.5	
Control Delay (s/veh)		8.1														11.3	
Level of Service, LOS		A														B	
Approach Delay (s/veh)		1.1												11.3			
Approach LOS														B			

HCS 2010 Two-Way Stop-Control Report

General Information

Analyst	MSH
Agency/Co.	Solaegui Engineers
Date Performed	12/22/2016
Analysis Year	2026
Time Analyzed	PM Base
Intersection Orientation	East-West
Project Description	

Site Information

Intersection	Geiger & Shadow Hills
Jurisdiction	NDOT
East/West Street	Geiger Grade
North/South Street	Shadow Hills Drive
Peak Hour Factor	0.92
Analysis Time Period (hrs)	0.25

Lanes

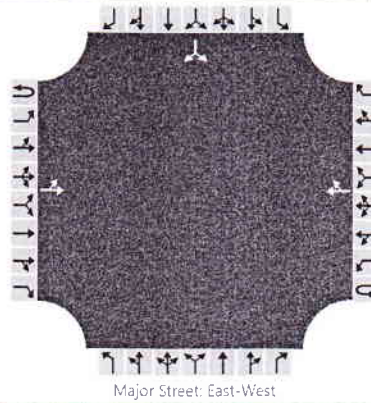

Vehicle Volumes and Adjustments

Approach	Eastbound				Westbound				Northbound				Southbound				
	U	L	T	R	U	L	T	R	U	L	T	R	U	L	T	R	
Movement	1U	1	2	3	4U	4	5	6		7	8	9		10	11	12	
Priority																	
Number of Lanes	0	0	1	0	0	0	1	0		0	0	0		0	0	0	
Configuration		LT						TR							LR		
Volume, V (veh/h)		58	366				209	7						6		45	
Percent Heavy Vehicles (%)		3												3		3	
Proportion Time Blocked																	
Percent Grade (%)																0	
Right Turn Channelized		No				No				No				No			
Median Type/Storage	Undivided																

Critical and Follow-up Headways

Base Critical Headway (sec)																
Critical Headway (sec)																
Base Follow-Up Headway (sec)																
Follow-Up Headway (sec)																

Delay, Queue Length, and Level of Service

Flow Rate, v (veh/h)		63														56
Capacity, c (veh/h)		1325														696
v/c Ratio		0.05														0.08
95% Queue Length, Q ₉₅ (veh)		0.1														0.3
Control Delay (s/veh)		7.9														10.6
Level of Service, LOS		A														B
Approach Delay (s/veh)		1.5								10.6						
Approach LOS										B						

HCS 2010 Two-Way Stop-Control Report

General Information				Site Information			
Analyst	MSH	Intersection	Geiger & Shadow Hills				
Agency/Co.	Solaegui Engineers	Jurisdiction	NDOT				
Date Performed	12/22/2016	East/West Street	Geiger Grade				
Analysis Year	2026	North/South Street	Shadow Hills Drive				
Time Analyzed	AM Base + Project	Peak Hour Factor	0.92				
Intersection Orientation	East-West	Analysis Time Period (hrs)	0.25				
Project Description							

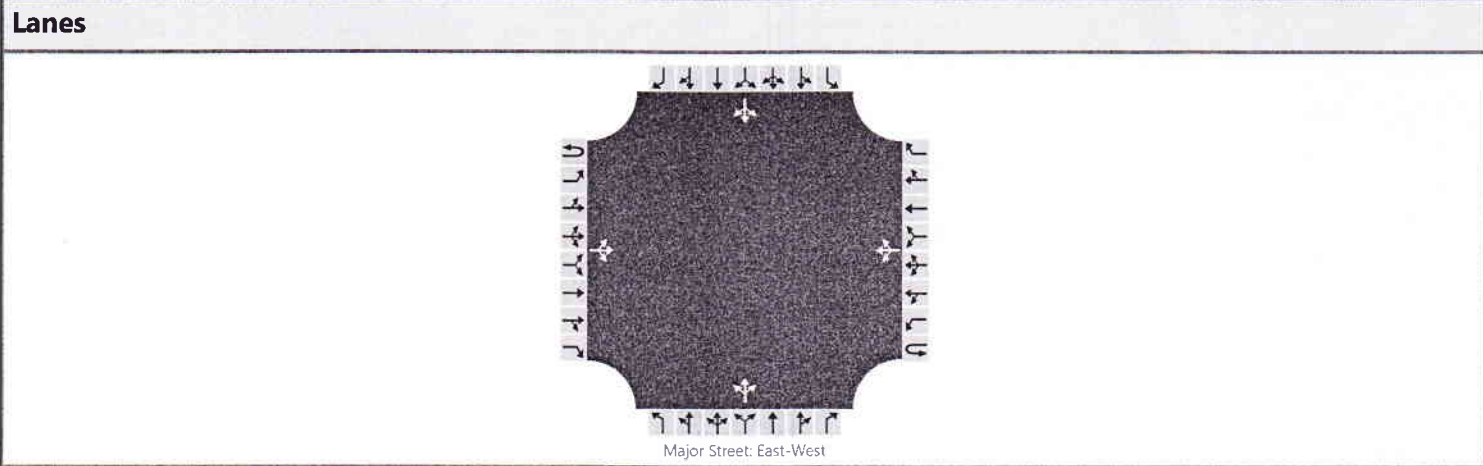

Vehicle Volumes and Adjustments

Approach	Eastbound				Westbound				Northbound				Southbound			
	U	L	T	R	U	L	T	R	U	L	T	R	U	L	T	R
Movement	1U	1	2	3	4U	4	5	6		7	8	9		10	11	12
Priority																
Number of Lanes	0	0	1	0	0	0	1	0	0	1	0		0	1	0	
Configuration			LTR				LTR				LTR				LTR	
Volume, V (veh/h)		15	108	10		1	335	2		29	0	2		3	0	85
Percent Heavy Vehicles (%)		3				3				3	3	3		3	3	3
Proportion Time Blocked																
Percent Grade (%)										0				0		
Right Turn Channelized		No			No				No			No				
Median Type/Storage	Undivided															

Critical and Follow-up Headways

Base Critical Headway (sec)																
Critical Headway (sec)																
Base Follow-Up Headway (sec)																
Follow-Up Headway (sec)																

Delay, Queue Length, and Level of Service

Flow Rate, v (veh/h)		16			1					34					95
Capacity, c (veh/h)		1186			1450					382					667
v/c Ratio		0.01			0.00					0.09					0.14
95% Queue Length, Q ₉₅ (veh)		0.0			0.0					0.3					0.5
Control Delay (s/veh)		8.1			7.5					15.3					11.3
Level of Service, LOS		A			A					C					B
Approach Delay (s/veh)		1.0			0.0				15.3			11.3			
Approach LOS									C			B			

HCS 2010 Two-Way Stop-Control Report

General Information

Analyst	MSH
Agency/Co.	Solaegui Engineers
Date Performed	12/22/2016
Analysis Year	2026
Time Analyzed	PM Base + Project
Intersection Orientation	East-West
Project Description	

Site Information

Intersection	Geiger & Shadow Hills
Jurisdiction	NDOT
East/West Street	Geiger Grade
North/South Street	Shadow Hills Drive
Peak Hour Factor	0.92
Analysis Time Period (hrs)	0.25

Lanes

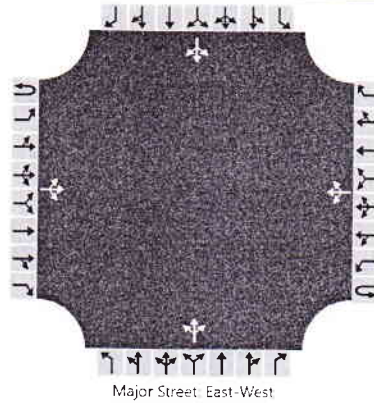

Vehicle Volumes and Adjustments

Approach	Eastbound				Westbound				Northbound				Southbound				
	U	L	T	R	U	L	T	R	U	L	T	R	U	L	T	R	
Movement	1U	1	2	3	4U	4	5	6		7	8	9		10	11	12	
Priority																	
Number of Lanes	0	0	1	0	0	0	1	0		0	1	0		0	1	0	
Configuration			LTR				LTR				LTR				LTR		
Volume, V (veh/h)		58	366	33		2	209	7		20	0	1		6	0	45	
Percent Heavy Vehicles (%)		3				3				3	3	3		3	3	3	
Proportion Time Blocked																	
Percent Grade (%)										0				0			
Right Turn Channelized		No				No				No				No			
Median Type/Storage		Undivided															

Critical and Follow-up Headways

Base Critical Headway (sec)																
Critical Headway (sec)																
Base Follow-Up Headway (sec)																
Follow-Up Headway (sec)																

Delay, Queue Length, and Level of Service

Flow Rate, v (veh/h)		63				2					23					56
Capacity, c (veh/h)		1325				1119					275					663
v/c Ratio		0.05				0.00					0.08					0.08
95% Queue Length, Q ₉₅ (veh)		0.1				0.0					0.3					0.3
Control Delay (s/veh)		7.9				8.2					19.3					10.9
Level of Service, LOS		A				A					C					B
Approach Delay (s/veh)		1.4				0.1				19.3				10.9		
Approach LOS										C				B		

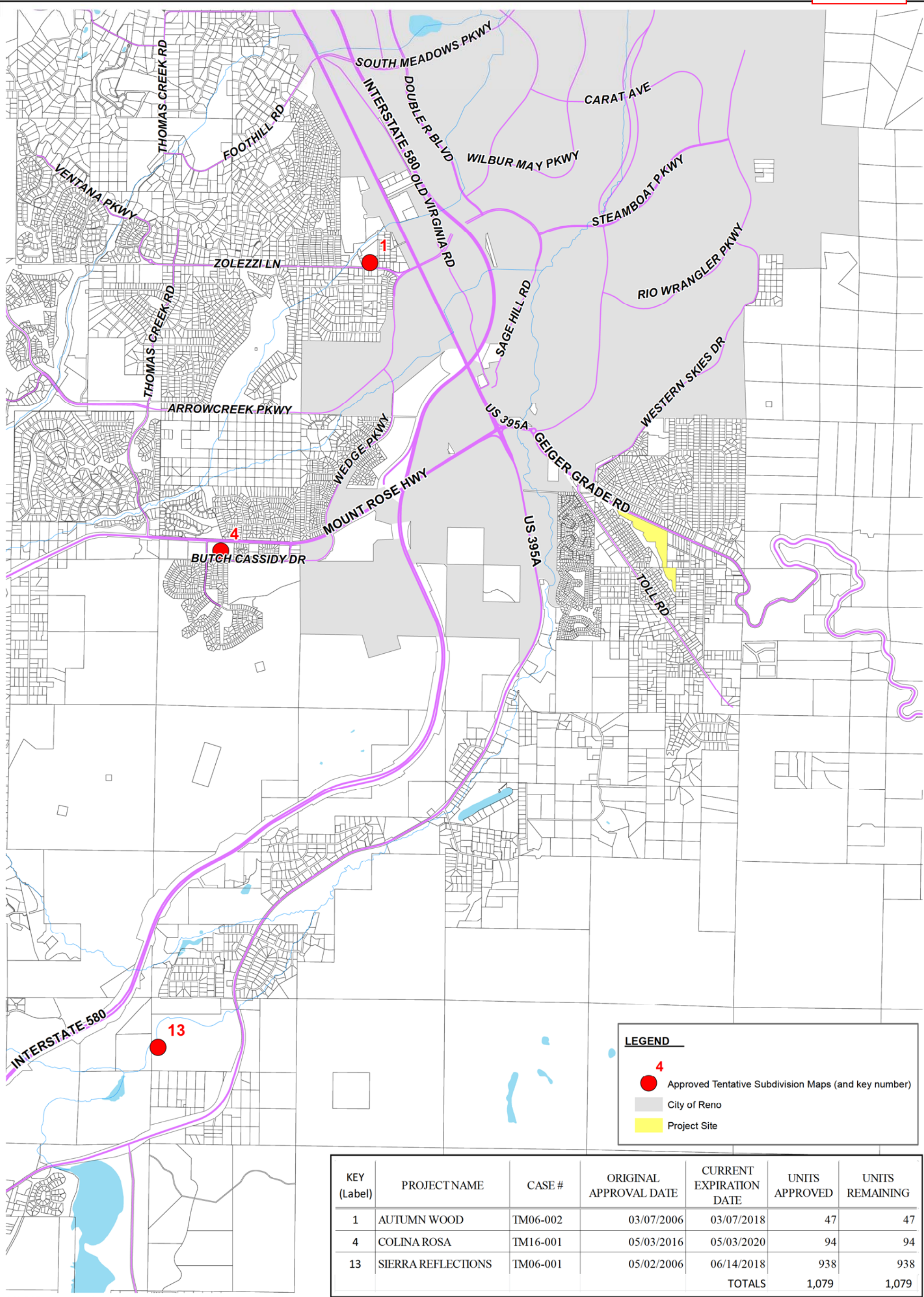

SOURCE: Community Services Department, Planning and Development Division

**Planning and Development
Community Services Department**

0 0.5 1
Miles

**Approved Residential Subdivisions
TOLL ROAD VICINITY**

**WASHOE COUNTY
NEVADA**

Post Office Box 11130
Reno, Nevada 89520

December, 2016
(775) 328-3600